

UNIT I INTRODUCTION

Design of the body for safety
Energy equation
Engine location
Deceleration of vehicle inside passenger compartment
Deceleration on impact with stationary and movable obstacle
Concept of crumple zone
Safety sandwich construction

INTRODUCTION:

- **Automobile safety** is the study and practice of design cars, construction, equipment and regulation to minimize the occurrence and consequences of traffic collisions.

CRASHWORTHINESS:

Crashworthiness is also highly dependent on how the materials, construction and design of the vehicle work together. From a collision point of view, a vehicle can be considered as two primary kinds of structure. First, there is the passenger cabin, within which the occupants should be belted to the seating. This compartment should represent a 'safety cage'. Ideally this cage will not distort or deform. Trapping feet with a collapsing firewall or having the roof structure deform onto heads is extremely poor from an injury point of view. Very strong passenger compartments are essential for these safety cages. The present material of choice for primary structural pillars is boron-containing hot stamped steels, which have very high strength and are easily manufacturable. The other important element is the crush zone that surrounds the cabin. This zone is tuned to absorb energy and provide deformation. Crash performance is improved by controlling the acceleration of an occupant's chest and minimizing a head injury criterion, which is also related to peak rates of acceleration or G-loading. Vehicle safety standards are based on these measures. To receive a 5-star crash rating, a passenger's chest should receive fewer than 48 Gs of acceleration when a vehicle impacts with a fixed rigid barrier. Therefore, from a design point of view, the crush zone should crush from its original shape to nearly zero thickness in front of the cabin compartment, ideally with a nearly constant force that is no greater than 48 times the vehicle weight while the safety cage remains undeformed. For the deforming members, high strength or stiffness is not desired, but what is important is the ability to absorb energy in a controlled manner and the ability to crush the full distance from the bumper to cabin, while the force remain near the peak value it maximizes the energy absorbed. Governmental regulation impose strict standards on occupant protection, and on various crash modes including side impact and roof crush. The mass of vehicles could be dramatically reduced if crashworthiness were not a consideration.

TYPES OF IMPACTS IN CAR ACCIDENTS:

The impacts in car accidents are of three types.

1. **VEHICLE IMPACT:** The initial strike involves the exterior of the vehicle crashing into something, such as another vehicle. Factors to consider here are the weight of the vehicles or objects, the speed of travel, and how fast the vehicle stopped. These factors all dictate the force exerted, with speed being the one that has the largest potential impact. The weight of a vehicle proportionally heightens the amount of force; however, speed does so exponentially, thus it greatly affects the potential severity. Older vehicles were traditionally designed to be resistant to forces in a collision, but in recent years the vehicles are instead manufactured to better absorb the force and keep the passenger

area better protected.

2. **BODY IMPACT** The second impact is the result of the occupant's body striking something inside of the vehicle. The body will typically be thrust toward the point of exterior impact and either be restrained by a seat belt or stopped by striking an inside object—both of which are dangerous. It is also critical to remember that any unsecured objects within the vehicle may also become potentially damaging projectiles. Examples of such objects may include a glass beverage container, a briefcase, or a tool box.
3. **ORGAN IMPACT:** The third impact relates to the damage occurring inside of the body, such as to the internal organs. A common example occurs when your brain abruptly strikes the skull that surrounds it. Organs that are solidly composed like the spleen or liver may be fractured and suffer harmful bleeding. Key vessels like the aorta could be damaged, which is largely responsible for blood flow, creating a potentially deadly situation.

DESIGN OF VEHICLE BODY FOR SAFETY

- The safety of a vehicle and its passengers can be improved by properly designing and selecting the material for vehicle bodies.
- The vehicle body structure is subjected to static and dynamic service loads during the life cycle. It also has to maintain its integrity and provide adequate protection in survivable crashes.
- At present there are two designs of vehicle body constructions: 1. Body over frame structure and 2. Uni- body structure.

Necessary features of a safe vehicle body:

- Deformable yet stiff front structure with crumple zones to absorb the crash kinetic energy from frontal collisions
- Deformable rear structure to safeguard rear passenger compartment and protect the fuel tank
- Properly designed side structures and doors to minimize intrusion in side impact and prevent doors from opening due to crash loads
- Strong roof structure for rollover protection
- Properly designed restraint systems with working in harmony with the vehicle structure
- Accommodate various chassis designs for different power train locations and drive train configurations.

Design techniques/strategies:

The following design techniques/strategies are to be followed while designing a car body (especially front structure) to reduce the impact of crash and increase the safety of the car and passengers.

Desired dummy performance:

- Dummy is a physical model representing humans inside a car.
- To model a car for safety, it should be modeled for proper crash energy management.
- As the human beings are to be safeguarded, the interaction of the human beings with the restraint system during a crash has to be studied first. This branch of study is widely known as bio-mechanics.
- The reaction of a human being for a crash pulse has to be defined and studied in depth. The following steps are involved in this procedure

Stiff cage structural concept:

- Stiff cage is the passenger compartment structure which provides protection for the passengers in all modes of survivable collisions.
- The necessary features of a good stiff cage structure are: 1. sufficient peak load capacity to support the energy absorbing members in front of it, 2. High crash energy absorption. The stiff cage structure should withstand all the extreme loads and the severe deformation.

Controlled progressive crush and deformation with limited intrusion:

- To make the impact of crash less, the crush event has to be controlled and the deformation should be made such that the intrusion of other components into the passenger compartment is less.
- Axial mode of crush is preferred to bending mode of crush as bending mode has lower energy content.
- To achieve this objective three different crush zones are identified:
 - Soft front zone: Reduces the aggressivity of crash in pedestrian / vehicle and vehicle / vehicle collisions
 - Primary crush zone: It consists of the main energy absorbing structure before the power train. It is characterized by a relatively uniform progressive structural collapse.
 - Secondary crush zone: Lies between the primary zone and passenger compartment and sometimes extends into the passenger compartment up to firewall. It provides a stable platform for the primary zone and transfers the load to the occupant compartment as efficiently as possible.

Weight efficient energy absorbing structures:

- The architecture of the structural frame (structural topology) design depends on the ability to design the primary crush zone for bending, folding, mixed folding and bending.
- For a given vehicle package different topologies have to be studied for the same crush energy absorption. The steps followed are:
 - Create a simple model of vehicle front end system
 - Determine the design loads of structural members

ENERGY EQUATION

- The application of the conservation of energy principle provides a powerful tool for problem solving.
- Newton's laws are used for the solution of many standard problems, but often there are methods using energy which are more straightforward.
- The basic reason for the advantage of the energy approach is that just the beginning and ending energies need be considered; intermediate processes do not need to be examined in detail since conservation of energy guarantees that the final energy of the system is the same as the initial energy.
- The work-energy principle is also a useful approach to the use of conservation of energy in mechanics problem solving. It is particularly useful in cases where an object is brought to rest as in a car crash or the normal stopping of an automobile.

- Kinetic energy is energy of motion. Objects that are moving, have kinetic energy (KE). If a car crashes into a wall at 5 mph, it shouldn't do much damage to the car. But if it hits the wall at 40 mph, the car will most likely be totaled. Kinetic energy is similar to potential energy. The more the object weighs, and the faster it is moving, the more kinetic energy it has. The formula for KE is: $KE = 1/2 * m * v^2$ where m is the mass and v is the velocity.
- The kinetic energy increases with the velocity squared. This means that if a car is going twice as fast, it has four times the energy. It may be noticed that the car accelerates much faster from 0 mph to 20 mph than it does from 40 mph to 60 mph. Let's compare how much kinetic energy is required at each of these speeds. At first glance, you might say that in each case, the car is increasing its speed by 20 mph, and so the energy required for each increase must be the same. But this is not so. We can calculate the kinetic energy required to go from 0 mph to 20 mph by calculating the KE at 20 mph and then subtracting the KE at 0 mph from that number. In this case, it would be $1/2 * m * 20^2 - 1/2 * m * 0^2$. Because the second part of the equation is 0, the $KE = 1/2 * m * 20^2$, or 200 m. For the car going from 40 mph to 60 mph, the $KE = 1/2 * m * 60^2 - 1/2 * m * 40^2$; so $KE = 1,800 m - 800 m$, or 1000 m. Comparing the two results, we can see that it takes a KE of 1,000 m to go from 40 mph to 60 mph, whereas it only takes 200 m to go from 0 mph to 20 mph.
- There are a lot of other factors involved in determining a car's acceleration, such as aerodynamic drag, which also increases with the velocity squared. Gear ratios determine how much of the engine's power is available at a particular speed, and traction is sometimes a limiting factor. So it's a lot more complicated than just doing a kinetic energy calculation, but that calculation does help to explain the difference in acceleration times.

ENGINE LOCATION

Front engine:

- The large mass of an engine at the front of the car gives the driver protection in the event of a head on collision.
- Engine cooling is simpler to arrange and in addition the cornering ability of a vehicle is normally better if the weight is concentrated at the front.

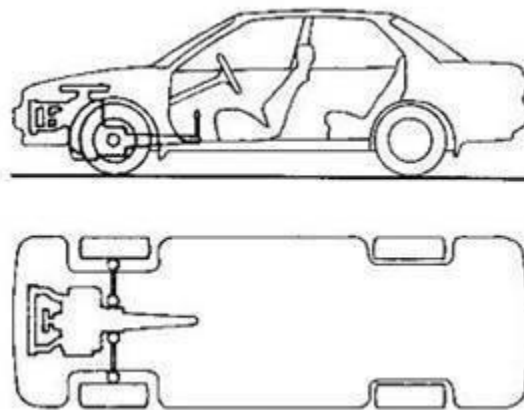

Figure 1.1. Location of engine in front engine vehicle.

- Advantages:
 - Better axle load distribution
 - Better road grip
 - Comfort riding
 - Better cooling
 - Less noise (long exhaust pipe)
 - Use a long engine

Rear engine:

- It increases the load on the rear driving wheels, giving them better grip of the road. Most rear-engine layouts have been confined to comparatively small cars, because the heavy engine at the rear has an adverse effect on the ‘handling’ of the car by making it ‘tail-heavy’.
- Also it takes up good deal of space that would be used on a front-engine car for carrying luggage.
- Most of the space vacated by the engine at the front end can be used for luggage, but this space is usually less than that available at the rear.

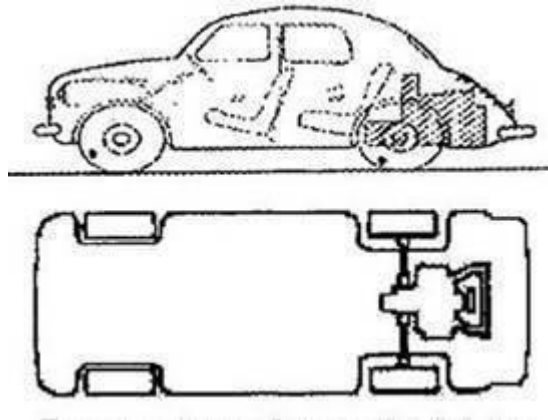

Figure 1.2. Location of engine in rear engine vehicle.

Central and mid-engine:

- These engine situations generally apply to sports cars because the engine sitting gives a load distribution that achieves both good handling and maximum traction from the driving wheels.
- These advantages, whilst of great importance for special cars, are outweighed in the case of everyday cars by the fact that the engine takes up space that would normally be occupied by passengers.
- The mid-engine layout shown combines the engine and transmission components in one unit. The term mid-engine is used because the engine is mounted in front of rear axle line.

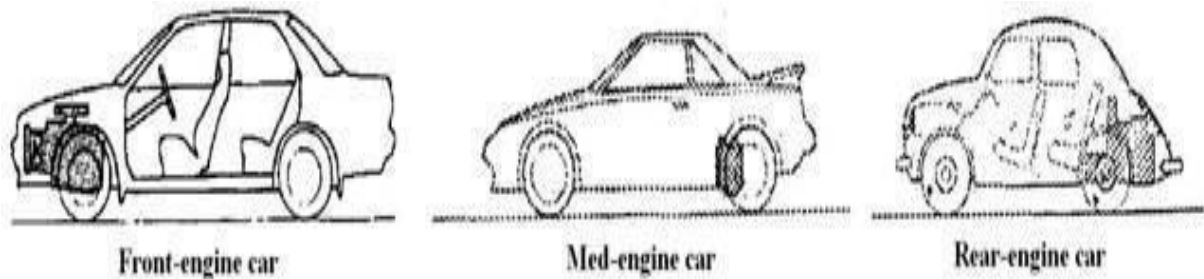

Figure 1.3. Location of engine in different types of cars.

DECELERATION OF VEHICLE AND PASSENGER COMPARTMENT ON IMPACT WITH STATIONARY AND MOVABLE OBSTACLE

It is important to study the deceleration inside passenger compartment to know the effect of crash completely, so that the crash avoidance systems can be suitably designed. For example, if the deceleration of the passenger after crash is very high, the air bag system and the seat belt system has to be so designed that the activation time for them is reduced to a lower value. Otherwise it may lead to injuries and fatalities.

Usually tests are conducted to know the deceleration behavior after the crash with a stationary obstacle. The tests are conducted at the following speeds:

1. 15 mph (miles per hour)
2. 20 mph
3. 40 mph
4. 50 mph

15 mph test:

The following pictures show the body deformation and acceleration graph after crash. The body deformation is less as the vehicle speed is low. The crash occurs at time 0 seconds. From the graph, we can know that after the crash, deceleration occurs which is shown in the negative (lower) portion. Its value is up to 20g. After some time the acceleration slowly comes to zero (the car stops)

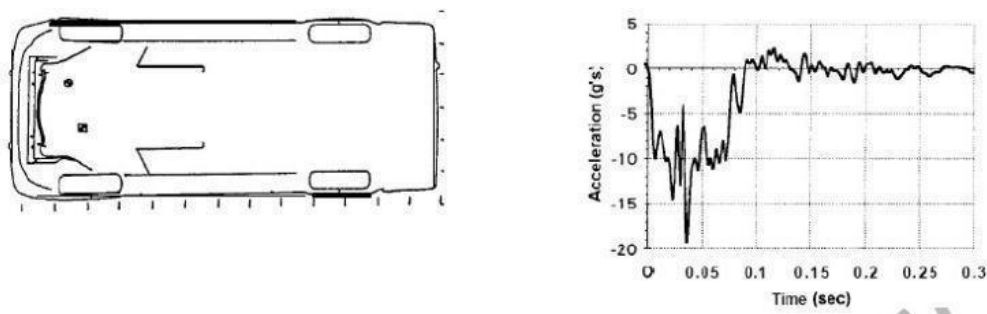

Figure 1.4. Deceleration characteristics in car after impact with stationary object (at 15 mph speed testing condition).

20 mph test:

In the 20 mph test, the body deformation is more than 15 mph test. Moreover, the acceleration has reduced to a further lower value (up to 35 g) in the negative direction. In this case the maximum deceleration is obtained in 50 milli seconds whereas for 10 mph test it was 35 milli seconds. The rebound velocity for this case is 1.7 mph whereas for 10 mph it is 1.3 mph. 40 mph test: In the 40 mph test, we can see that the acceleration curve goes down (deceleration) then suddenly goes up in the positive region (acceleration). This is due to the fact that, at 40 mph, the deformation is more and the accelerometer (sensor) mounting area has buckled and resulted in an increase in acceleration value. The body deformation is also high such that the accelerometer mounting area is also damaged. So, we have to carefully analyze the graph to study the situation.

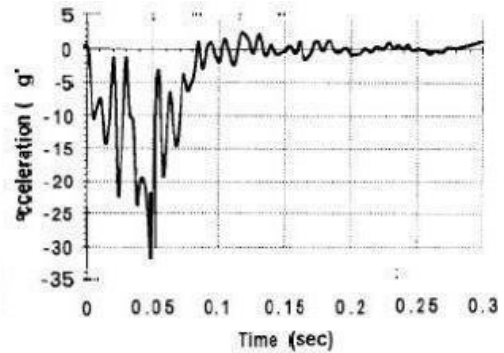
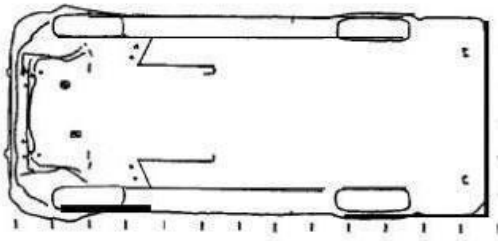

Figure 1.5. Deceleration characteristics in car after impact with stationary object (at 20 mph speed testing condition).

40 mph test:

In the 40 mph test, we can see that the acceleration curve goes down (deceleration) then suddenly goes up in the positive region (acceleration). This is due to the fact that, at 40 mph, the deformation is more and the accelerometer (sensor) mounting area has buckled and resulted in an increase in acceleration value. The body deformation is also high such that the accelerometer mounting area is also damaged. So, we have to carefully analyze the graph to study the situation.

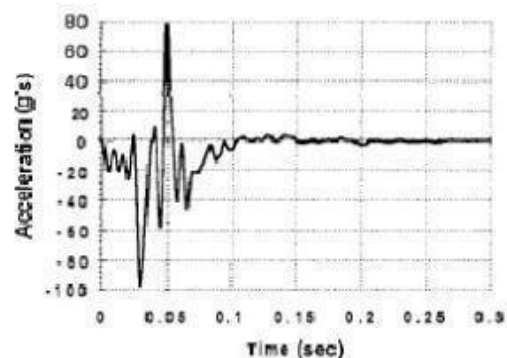
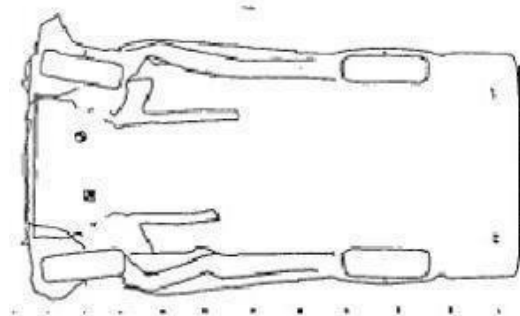

Figure 1.6. Deceleration characteristics in car after impact with stationary object (at 40 mph speed testing condition).

50 mph test:

The body deformation is very high as the speed is more. The acceleration curve shows that the maximum deceleration is around 35g and happens in time duration of 45 milli seconds. The rebound velocity is 1.6 mph.

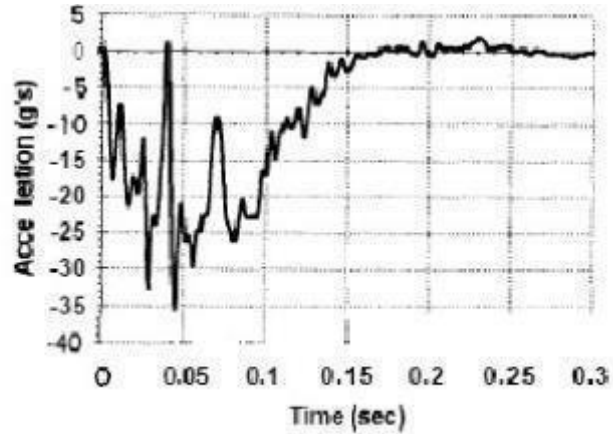
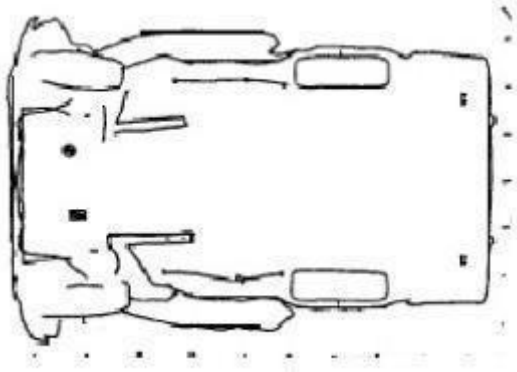

Figure 1.7. Deceleration characteristics in car after impact with stationary object (at 50 mph speed testing condition).

DECELERATION ON IMPACT WITH A MOVABLE OBSTACLE:

A movable obstacle can be another car or any other vehicle. Let us consider a car is impacting with another car. We shall study for the two cars; one car which is impacting the second car, the other car is which is being impacted. In this case the test is conducted at 40 mph.

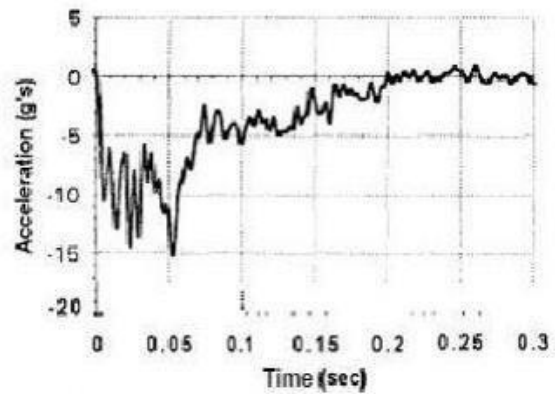
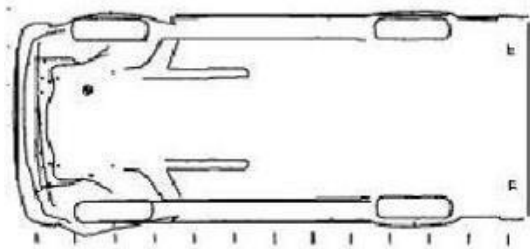

Figure 1.8. Deceleration characteristics in car after impact with movable object (at 40 mph speed testing condition).

The impact velocity was 40.6 mph with a separation velocity of 18.0 mph for a total velocity change of 22.6 mph. A maximum of 15g's deceleration was achieved at about 50 milliseconds. The total impact duration was approximately 195 milliseconds

Impacted vehicle:

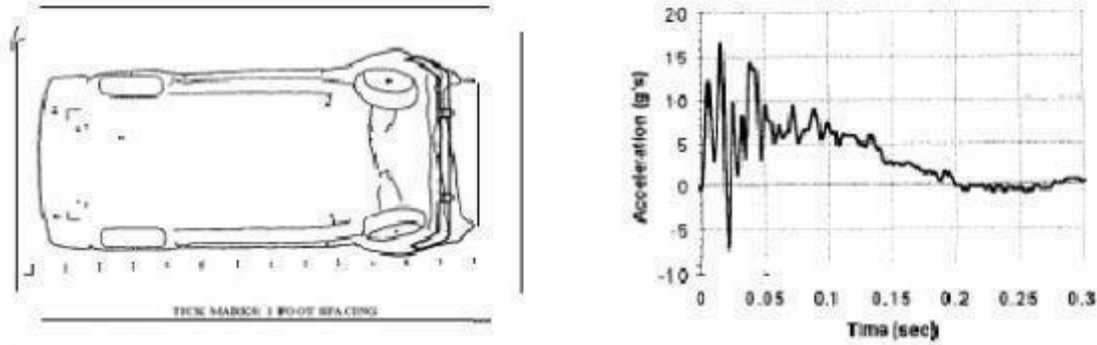

Figure 1.9. Deceleration characteristics in car after impact with movable object (at 18 mph speed testing condition).

The pre-impact velocity was 0.0 mph with a separation velocity of 22.8 for a total velocity change of 22.8mph. A maximum of 16.5g's acceleration was achieved at about 15 milliseconds. The total impact duration was approximately 195 milliseconds.

CONCEPT OF CRUMBLE ZONE

- Crumple zones are designed to absorb the energy from the impact during a traffic collision by controlled deformation.
- The crumple zone of an automobile is a structural feature designed to compress during an accident to absorb energy from the impact. Typically, crumple zones are located in the front part of the vehicle, in order to absorb the impact of a head-on collision, though they may be found on other parts of the vehicle as well. Some racing cars use aluminum or composite honeycomb to form an 'impact attenuator' for this purpose.
- It was an inventor Bela Barenyi who pioneered the idea that passengers were safer in a vehicle that was designed to easily absorb the energy from an impact and keep that energy away from the people inside the cabin. Barenyi devised a system of placing the car's components in a certain configuration that kept the kinetic energy in the event of a crash away from a bubble protecting the car's occupants.
- Mercedes obtained patent from Barenyi's invention way back in 1952 and the technology was first introduced into production cars in 1959 in the Mercedes-Benz 220, 220 S and 220 SE models.

Auto safety has come a long way in the last few decades, and one of the most effective innovations is the crumple zone. Also known as a crush zone, crumple zones are areas of a vehicle that are designed to deform and crumple in a collision. This absorbs some of the energy of the impact, preventing it from being transmitted to the occupants.

Of course, keeping people safe in auto accidents isn't as simple as making the whole vehicle crumple. Engineers have to consider many factors in designing safer cars, including vehicle size and weight, frame stiffness and the stresses the car is likely to be subjected to in a crash. For example, race cars

experience far more severe impacts than street cars, and SUVs often crash with more force than small cars.

Function:

- Crumple zones work by managing crash energy, absorbing it within the outer sections of the vehicle, rather than being directly transmitted to the occupants, while also preventing intrusion into or deformation of the passenger cabin.
 - This better protects car occupants against injury. This is achieved by controlled weakening of sacrificial outer parts of the car, while strengthening and increasing the rigidity of the inner part of the body of the car, making the passenger cabin into a 'safety cell', by using more reinforcing beam and higher strength steels. Volvo introduced the side crumple zone; with the introduction of the SIPS (Side Impact Protection System) in the early 1990s.
- The purpose of crumple zones is to slow down the collision and to absorb energy. It is like the difference between slamming someone into a wall headfirst (fracturing their skull) and shoulder-first (bruising their flesh slightly) is that the arm, being softer, has tens of times longer to slow its speed, yielding a little at a time, than the hard skull, which isn't in contact with the wall until it has to deal with extremely high pressures.
- Seatbelts restrain the passenger so they don't fly through the windshield, and are in the correct position for the airbag and also spread the loading of impact on the body. Seat belts also absorb energy by being designed to stretch during an impact, so that there is less speed differential between the passenger's body and their vehicle interior. In short: A passenger whose body is decelerated more slowly due to the crumple zone (and other devices) over a longer time, survives much more often than a passenger whose body indirectly impacts a hard, undamaged metal car body which has come to a halt nearly instantaneously.
- The final impact after a passenger's body hits the car interior, airbag or seat belts, is that of the internal organs hitting the ribcage or skull. The force of this impact is the mechanism through which car crashes cause disabling or life threatening injury. The sequence of energy is dissipating and speed reducing technologies - crumple zone - seat belt - airbags - padded interior, are designed to work together as system, to reduce the force of this final impact.
- A common misconception about crumple zones is that they reduce safety by allowing the vehicle's body to collapse, crushing the occupants. In fact, crumple zones are typically located in front and behind of the main body (though side impact absorption systems are starting to be introduced), of the car (which forms a rigid 'safety cell'), compacting within the space of the engine compartment or boot/trunk.
- The marked improvement over the past two decades in high speed crash test results and real-life accidents also belies any such fears.
- Modern vehicles using what are commonly termed 'crumple zones' provide far superior protection for their occupants in severe tests than older models, or SUVs that use a separate chassis frame and have no crumple zones.

SAFETY SANDWICH CONSTRUCTION:

- Sandwich panel constructions using metallic and polymeric honeycombs and foams have been used for many years in the competition and high performance sectors of the automotive industry, and there is considerable knowledge and confidence in their static, dynamic and crashworthiness properties.
- Sandwich panels have only been used to produce extremely limited numbers of product and have been essentially hand-worked.
- The potential advantages of polymer composites for automotive parts (high specific strength and stiffness, corrosion resistance) are well known. Further benefits are available from the use of sandwich construction, in which a relatively stiff, strong skin is bonded either side of a much thicker, lightweight core.
- Sandwich panels have been widely used for structural applications in the marine, aerospace and performance automotive industries for several decades.
- Lightweight core materials have included balsa, polymer foams and metallic, paper or polymer honeycombs. These have been used in various combinations with skins of carbon, glass and/or aramid fiber-reinforced polymer, as well as aluminium. The principle of sandwich construction is that bending loads are carried by the skins, while the core transmits shear load.
- They enable large gains in structural efficiency, since the thickness (and hence flexural rigidity) of panels can be increased without significant weight penalty.
- In high performance car construction, most sandwich panel elements are vacuum bag/autoclave molded on a contact tool, usually in several stages (e.g. first skin; core to skin bond; second skin).
- Although this permits complex shapes to be produced on low cost tooling, it is necessarily a time consuming and labor intensive process.
- A high degree of cleanliness and sophisticated process control are required, and inspection is notoriously difficult.
- Sandwich panels are also available as flat sheet, stock material.
- Hexcel Composites, for example, supply a range of honeycomb cored sheets of varying specifications which is widely used for building cladding, aircraft flooring, luggage bins and bulkheads.
- The use of a stock material is attractive, since primary material quality and specification becomes the responsibility of the supplier, not the manufacturer.
- Several techniques are well established for the shaping and assembly of structural components from flat sandwich panel. Panels may be bent to required angles by removing a defined strip of material from the inner skin, then folding and adhesively bonding the joint.