

# 19MEB301 CAD/CAM&AUTOMATION

Prepared by,

**V.KARTHIK**

**P.JANAGARATHINAM**

Assistant professor

Mechanical engineering

SNS college of technology.

# TABLE OF CONTENTS

<b>SYLLABUS .....</b>	<b>10</b>
<b>UNIT-I COMPUTER AIDED DESIGN AND GEOMETRIC MODELING .....</b>	<b>12</b>
<b>DESIGN.....</b>	<b>12</b>
DESIGN DISCIPLINES .....	12
<b>ENGINEERING DESIGN.....</b>	<b>12</b>
<b>1.1 COMPUTER AIDED DESIGN .....</b>	<b>12</b>
<b>MANUFACTURING .....</b>	<b>13</b>
<b>MANUFACTURING PROCESSES.....</b>	<b>13</b>
<b>COMPUTER AIDED MANUFACTURING .....</b>	<b>13</b>
<b>COMPUTER INTEGRATED MANUFACTURING .....</b>	<b>13</b>
<b>NEED FOR CAD/CAM/CIM.....</b>	<b>13</b>
<b>SCOPE OF CAD/CAM/CIM .....</b>	<b>14</b>
USES OF CAD .....	14
<b>ELEMENTS OF DESIGN THE PROCESS.....</b>	<b>15</b>
<b>THE DESIGN PROCESS.....</b>	<b>15</b>
1. RECOGNITION OF NEED .....	15
2. DEFINITION OF PROBLEM.....	15
3. SYNTHESIS .....	16
4. ANALYSIS AND OPTIMIZATION .....	16
5. EVALUTION .....	16
6. PRESENTATION.....	16
BENEFITS OF CAD .....	16
<b>1.2 GEOMETRIC TRANSFORMATIONS .....</b>	<b>17</b>
<b>2 D TRANSFORMATIONS.....</b>	<b>17</b>
SCALING .....	17
TRANSLATION.....	18
REFLECTION .....	20

ROTATION .....	21
<b>3 D transformation .....</b>	<b>23</b>
<b>1.3 Geometric modelling.....</b>	<b>24</b>
<b>Why Geometric modeling is needed .....</b>	<b>24</b>
Types of geometric modeling methods.....	24
<b>WIREFRAME MODELLING.....</b>	<b>25</b>
Advantages.....	25
Disadvantages .....	25
<b>Surface Modeling.....</b>	<b>25</b>
Advantages.....	25
Dis advantages .....	26
Surface Entities .....	26
Analytic entities include .....	26
Synthetic entities include .....	26
Plane surface .....	26
Ruled (lofted) surface .....	26
Surface of revolution.....	27
Tabulated cylinder. ....	27
Bezier surface.....	28
B-spline surface .....	28
<b>Solid Modeling.....</b>	<b>28</b>
Methods of Creating Solid Models.....	29
Primitive solids .....	29
Constructive Solid Geometry, (CSG) .....	30
Boundary Representation (B-rep).....	31
B-Rep data structure .....	31
Boundary representation- validity.....	32
Operation performed.....	33
<b>1.4 Finite element analysis.....</b>	<b>34</b>
HISTORY OF FEA.....	34
WHAT IS FINITE ELEMNT METHOD ? .....	34
GENERAL STEPS INVOLVED IN FINITE ELEMENT ANALYSIS .....	34

TYPES OF ANALYSIS .....	36
ONE MARKS .....	36
TWO MARKS .....	39
Big questions.....	46
<b>UNIT-II CNC MACHINE TOOLS AND COMPONENTS.....</b>	<b>47</b>
<b>Numerical control.....</b>	<b>47</b>
Basic Components .....	47
The EIA definition of computer numerical control (CNC) .....	48
<b>Direct Numerical Control (DNC).....</b>	<b>48</b>
The EIA definition of DNC .....	48
Minimal configuration of DNC .....	49
<b>DESIGN CONSIDERATION OF CNC MACHINE .....</b>	<b>49</b>
1-Design considerations for structure of CNC machine tool.....	49
2-Spindle design.....	50
3-Spindle drives and feed drives.....	50
4-Actuation systems.....	50
5-Feedback devices.....	50
Electrical Discharge Machining [EDM] .....	50
<b>2.2 COORDINATE MEASURING MACHINE (CMM) .....</b>	<b>52</b>
<b>COORDINATE MEASURING MACHINE.....</b>	<b>52</b>
The features of CMM software will include.....	53
TYPES OF CMM .....	54
ADVANTGES OF CNC OPERATION OF CMM .....	54
RECIRCULATING BALL SCREW .....	55
GUIDE WAYS .....	56
LINEAR MOTION GUIDE WAYS.....	56
Oil lubricated guide ways .....	57
TOOL MAGAZINES .....	57
TYPES OF TOOL MAGAZINES TURRET TYPE.....	57
DRUM TYPE.....	58
CHAIN TYPE.....	58
ATC (AUTOMATIC TOOL CHANGERS).....	58

APC ( AUTOMATIC PALLET CHANGE OVER).....	59
CHIP CONVEYORS .....	59
Micro processor based CNC system.....	60
<b>UNIT 2 Objective type questions .....</b>	<b>60</b>
<b>UNIT-III CNC CONTROL SYSTEM AND PART PROGRAMMING .....</b>	<b>64</b>
<b>Configuration of CNC machine .....</b>	<b>64</b>
Pneumatic systems .....	65
Components of a pneumatic system (case study refer ppt).....	66
Hydraulic System In CNC Machine .....	66
Open loop and closed loop control system .....	67
Controller .....	70
Open loop control system: .....	70
The closed-loop.....	70
Feedback .....	71
Linear scale .....	71
Encoder .....	71
CNC interpolation.....	72
Features of CNC .....	73
Feedback is provided by sensors.....	74
Machine Tool Zero Point Setting.....	76
Manual Setting.....	76
Absolute Zero Shift.....	76
<b>CLASSIFICATION OF CNC MACHINE TOOLS.....</b>	<b>77</b>
Point-to-point systems .....	78
Contouring systems (Continuous path systems).....	78
<b>3.3 CNC PROGRAMMING .....</b>	<b>79</b>
The part program.....	79
<b>MANUAL PART PROGRAMMING .....</b>	<b>80</b>
Computer Aided Part Programming .....	81
Standard G and M Codes .....	81
G-Codes (Preparatory Functions) .....	81
M-Codes (Miscellaneous Functions) .....	82

CNC terminology.....	83
BLU: basic length unit →.....	83
Controller: (Machine Control Unit, MCU) →.....	83
Types of CNC machines.....	83
FIXED CYCLE/CANNED CYCLE.....	91
1 MARKS.....	93
2 MARKS.....	94
14 MARKS.....	97
<b>UNIT IV - FLEXIBLE MANUFACTURING SYSTEMS.....</b>	<b>98</b>
<b>Syllabus.....</b>	<b>98</b>
<b>Books.....</b>	<b>98</b>
<b>1. AUTOMATION PRODUCTION -SYSTEMS-CIM BY GROOVER.....</b>	<b>98</b>
<b>Automation.....</b>	<b>99</b>
<b>4.1 What is automation.....</b>	<b>99</b>
<b>Basic elements of an automated system.....</b>	<b>99</b>
1. Power to Accomplish the Automated Process.....	100
2. Program of Instructions.....	100
3. Control System.....	101
<b>4.2 Advanced automation functions.....</b>	<b>102</b>
Safety monitoring.....	102
Maintenance and Repair Diagnostics.....	103
Error Detection.....	103
Error Recovery.....	103
<b>4.3 LEVELS OF AUTOMATION.....</b>	<b>104</b>
Device level.....	104
Machine level.....	104
Cell or system level.....	105
Plant level.....	105
Enterprise level.....	105
<b>4.4 Lean manufacturing or lean production,.....</b>	<b>105</b>
<b>4.5 JUST-IN-TIME production systems.....</b>	<b>106</b>
Pull system.....	106

Push system.....	106
Kanban .....	106
Production kanban and transport kanban .....	106
<b>4.6 Concurrent engineering.....</b>	<b>107</b>
<b>4.7 FMS (Flexible Manufacturing Systems) .....</b>	<b>108</b>
<b>4.8 Types of FMS.....</b>	<b>109</b>
1. Depending upon level of flexibility .....	109
2. Depending Upon Kinds Of Operation .....	110
2. Depending upon number of machines .....	110
<b>4.9 FMS COMPONENTS.....</b>	<b>111</b>
1. Workstations .....	112
2. Material Handling and Storage System .....	113
3. Computer Control System.....	113
4. Human Resources .....	114
<b>4.10 FMS Layout Configurations .....</b>	<b>114</b>
<b>4.11 FMS Benefits application.....</b>	<b>118</b>
<b>4.12 Automated Guided Vehicles.....</b>	<b>119</b>
AGVS Towing Vehicle.....	120
AGVS Pallet Trucks .....	120
AGVS forklift trucks.....	120
AGVS Light Load Transporters .....	120
Guidance Systems for AGVS .....	121
2MARKS .....	124
<b>Important Big Questions .....</b>	<b>125</b>
<b>UNIT-V COMPUTER INTEGRATED MANUFACTURING SYSTEMS.....</b>	<b>127</b>
<b>WHAT IS CIM? .....</b>	<b>127</b>
DEFINITION OF CIM (CASA/SME).....	127
CASA/SME"s CIM wheel .....	127
Historical review of CIM .....	128
WHY CIM ?.....	129
Objectives of CIM.....	129
CIM I VS CIM II .....	129

<b>Computerized Elements of CIM system.....</b>	<b>129</b>
Schematic diagram of CIM.....	131
Islands of automation.....	131
The new SME manufacturing enterprise wheel.....	132
CIM Hardware .....	132
CIM SOFTWARE .....	133
Potentials Benefits of CIM.....	133
Facilities Layout Design and Facilities Location.....	133
Need of Facilities Layout Design .....	133
Objectives of Facilities Layout Design.....	134
Types of Layout .....	134
Product layout .....	134
PROCESS LAYOUT .....	136
<b>NETWORKS .....</b>	<b>143</b>
ADVANTAGES OF NETWORKS .....	143
TYPES OF NETWORKS .....	144
Local area networks .....	144
Metropolitan area networks (MANS) .....	145
Wide area networks (WANs).....	146
<b>Network topology (types of communication line).....</b>	<b>146</b>
STAR (or) RADIAL TOPOLOGY.....	146
TREE TOPOLOGY .....	147
BUS TOPOLOGY .....	148
RING TOPOLOGY .....	149
COMPONENTS OF LAN .....	150
TYPES OF TRANSMISSION.....	150
TRANSMISSION MEDIA.....	151
<b>NETWORK ARCHITECTURES and PROTOCOLS .....</b>	<b>151</b>
Open system interconnection (OSI).....	151
Manufacturing Automation Protocol (MAP).....	151
The Technical and Office Protocol (TOP).....	151
Open system interconnection (OSI).....	152



Objective type questions .....	155
IMPORTANT QUESTIONS .....	158

# SYLLABUS

<b>ME403</b>	<b>CAD/CAM/CIM</b>	<b>L</b>	<b>T</b>	<b>P</b>	<b>C</b>
		<b>3</b>	<b>0</b>	<b>0</b>	<b>3</b>

<b>UNIT-I</b>	<b>COMPUTER AIDED DESIGN AND GEOMETRIC MODELING</b>	<b>9</b>
<p>Introduction – CAD definition – design process – CAD activities – benefits and scope of CAD. Transformations: Scaling, Rotation, Pan, Redraw, Regenerate-Geometric modeling techniques: wire frame, surface, solid modeling – Introduction to finite element methods – procedure of finite element analysis.</p>		

<b>UNIT-II</b>	<b>CNC MACHINE TOOLS AND COMPONENTS</b>	<b>9</b>
<p>Numerical control – development of NC – DNC – CNC and adaptive control systems – Distinguishing features of turning and machining center – design considerations of NC machine tools. CNC EDM machine – Coordinate measuring machines: construction, working principles and specifications – maintenance of CNC machines. Recirculating ball screw, linear motion guide ways, tool magazines, ATC, APC, chip conveyors, tool turrets</p>		

<b>UNIT-III</b>	<b>CNC CONTROL SYSTEM AND PART PROGRAMMING</b>	<b>9</b>
<p>Pneumatic and hydraulic control system, Open loop and closed loop control system, microprocessor based CNC system, description of hardware and software interpolation system, feedback devices: encoders – linear and rotary transducers – in-process probing. NC dimensioning –reference points – machine zero, work zero, tool zero and tool offsets, compensation. Coordinate system – types of motion control: point-to-point, paraxial and contouring – Types of NC part programming – G and M codes - turning and milling part programming examples - interpolation – macro – subroutines – canned cycles – mirror images.</p>		

<b>UNIT-IV</b>	<b>FLEXIBLE MANUFACTURING SYSTEMS</b>	<b>9</b>
<p>Basic Elements of an Automated -system – Levels of Automation – Lean Production and Just-In-Time Production. Concurrent Engineering - FMS-components of FMS - types -FMS workstation -material handling and storage systems- FMS layout -application and benefits</p>		

<b>UNIT-V</b>	<b>COMPUTER INTEGRATED MANUFACTURING SYSTEMS</b>	<b>9</b>
<p>Evolution of CAD/CAM and CIM - Integration of CNC machines in CIM environment, Definition- CIM Wheel- -CIM concepts – Computerized elements of CIM system –Types of production Communication fundamentals- local area networks -topology -LAN implementations - network management and installations - networking concepts, devices- CIM implementation</p>		

<b>L:45</b>	<b>T:0</b>	<b>T: 45 PERIODS</b>
-------------	------------	----------------------

<b>TEXT BOOKS</b>
<ol style="list-style-type: none"> <li>1. Mikell P. Groover, Automation, Production Systems, and Computer-Integrated Manufacturing, 2nd Edition, Reprint 2002, Pearson Education Asia. (Unit I,II,III,IV,V)</li> <li>2. P.Radhakrishnan, S.Subramanyam and V.Raju, CAD/CAM/CIM, New Age International, 3rd. 2008. (Unit I,II,III,IV,V)</li> </ol>
<b>REFERENCES</b>
<ol style="list-style-type: none"> <li>1. Chris McMahon and Jimmie Browne “CAD/CAM Principles- Practice and Manufacturing management” Addison-Wesley - <u>Pearson PLC United States</u> 2<sup>nd</sup> Edition, 1999 (Unit I, II, III, IV).</li> <li>2. P.N.Rao, CAD/CAM Principles and Applications, 2002, Tata McGraw Hill Publishing Company Ltd. (Unit I,II)</li> <li>3. Ibrahim Zeid, Mastering CAD/CAM, Special Indian Edition 2007, Tata McGraw-Hill Publishing Company Ltd., New Delhi. (Unit III,IV,V)</li> <li>4. YoramKoren, Computer control of manufacturing systems, New Delhi, DELHI, India International Edition 2005, McGrawHill Book Co. (Unit I, III,IV,V)</li> <li>5. Chennakesava R. Alavala CAD/CAM Concepts and applications 2008, Phi Learning Pvt. Ltd., (Unit I, II, III, IV, V).</li> </ol>
<b>WEB RESOURCES</b>
<ul style="list-style-type: none"> <li>• <a href="http://www.cadcamcim.com">www.cadcamcim.com</a></li> <li>• <a href="http://www.engr.psu.edu/cim">www.engr.psu.edu/cim</a></li> </ul>

<b>COURSE OUTCOMES</b>
<p>At the end of the course students should be able to</p> <ul style="list-style-type: none"> <li>• Depict the concept of CAD/CAM.</li> <li>• Analyze and implement the CNC tools and programs.</li> <li>• Portray how computers are integrated at various levels of planning and manufacturing to understand computer aided planning, control and computer monitoring</li> </ul>

<b>UNIT-I</b>	<b>COMPUTER AIDED DESIGN AND GEOMETRIC MODELING</b>	<b>9</b>
Introduction – CAD definition – design process – CAD activities – benefits and scope of CAD. Transformations: Scaling, Rotation, Pan, Redraw, Regenerate-Geometric modeling techniques: wire frame, surface, solid modeling – Introduction to finite element methods – procedure of finite element analysis.		

# UNIT-I      COMPUTER AIDED DESIGN AND GEOMETRIC MODELING

## DESIGN

Design is the human power to conceive, plan, and realize products that serve human beings, in the accomplishment of any individual or collective purpose.

## DESIGN DISCIPLINES

- Applied Arts/Fine Arts
- Architecture
- Fashion
- Gaming Industry
- Engg. Design

## ENGINEERING DESIGN

- Preliminary design
  - Schematics, diagrams, layouts of the project
- Detailed design
  - Operating parameters, Test, Materials, Packaging
- Production planning and tool design
  - Jigs, fixtures, and tooling
- Production
  - Mechanical Design
  - For Machines like Lathe, Drill,
  - For Turbo-machines like Turbine, Propeller
  - For Automobile like Chassis, Transmission
  - For Components like Gears, Shafts, Joints, etc

## 1.1 COMPUTER AIDED DESIGN

- Use of computer systems to assist in creation, modification, analysis and optimization of a design.
- Computer assistance, while a designer converts his or her ideas and knowledge, into a mathematical and graphical model represented in a computer.

## MANUFACTURING

Process of production of objects from metals or non-metals, with or without application of force, with or without application of heat, with or without use of machines, joining or removing of excess material.

## MANUFACTURING PROCESSES

- Chemical Process
- Mechanical Process as Bending
- NC/CNC Process as Turning, Facing
- Casting
- Molding
- Forming
- Machining
- Joining
- Rapid manufacturing

## COMPUTER AIDED MANUFACTURING

- Use of computers systems to plan, manage and control the operations of a manufacturing plant through either direct or indirect computer interface with plant's production resources.
- Manufacturing support applications –Use of computers in process planning, scheduling, shop floor control, work study, tool design, quality control etc

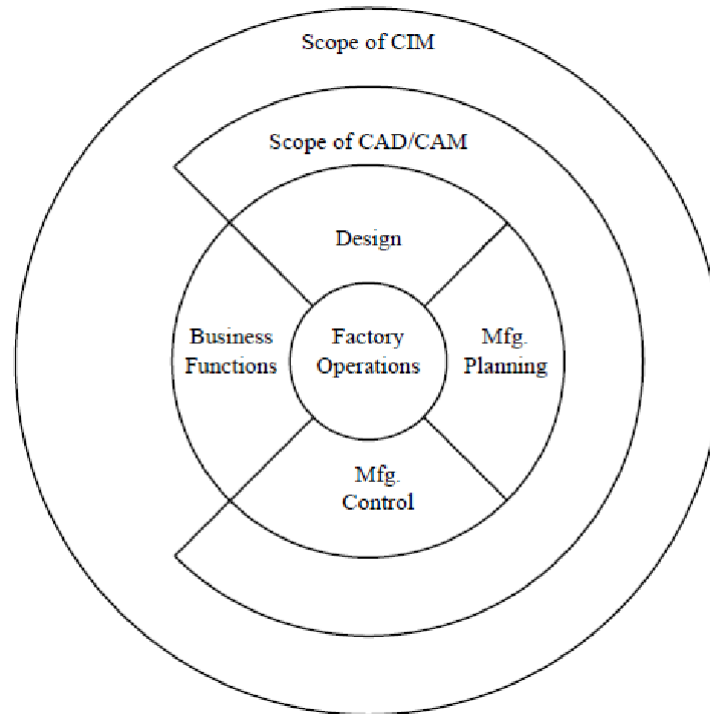
## COMPUTER INTEGRATED MANUFACTURING

- A process of integration of CAD, CAM and business aspects of a factory. It attempts complete automation with all processes functioning under computer control.

## NEED FOR CAD/CAM/CIM

- ✓ To increase productivity of the designer
- ✓ To improve quality of the design
- ✓ To improve communications
- ✓ To create a manufacturing database
- ✓ To create and test tool paths and optimize them
- ✓ To help in production scheduling and MRP models
- ✓ To have effective shop floor control

## SCOPE OF CAD/CAM/CIM



## USES OF CAD

CAD is used to design a variety of different products for a variety of fields such as

- Architecture
- Electronics
- Automotive engineering
- Industrial Design
- Machinery
- Visual Art
- Medical Design

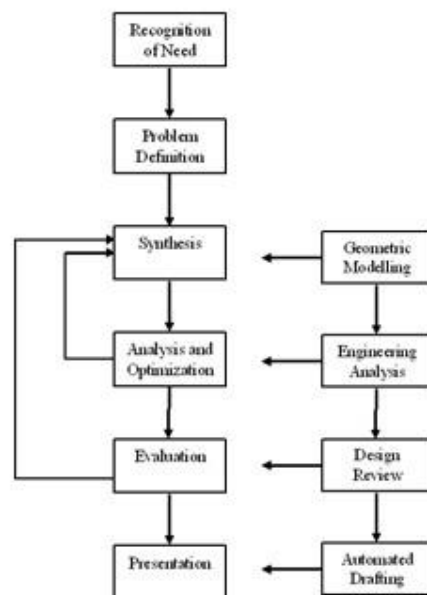


## ELEMENTS OF DESIGN THE PROCESS

- Problem Identification
- Research Phase
- Requirements Specification
- Concept Generation
- Design Phase
- Prototyping Phase
- System Integration
- Maintenance Phase

## THE DESIGN PROCESS:

### The Design Process : Then and Now



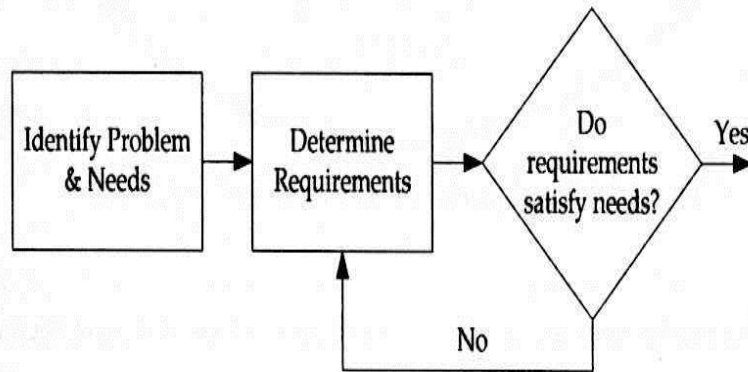
### Before CAD After CAD

#### 1. RECOGNITION OF NEED

It's involves the realization by someone that a problem exists for which some feasible solution to be found.

#### 2. DEFINITION OF PROBLEM

It's involved through specification of the item to be designed. The specification will generally include function and physical characteristics, cost, quality, performance etc.



**Figure 1.1** A prescriptive design process for problem identification and requirements selection.

### 3. SYNTHESIS

During the synthesis phase of the design process various preliminary ideas are developed through research of similar products or design in use.

### 4. ANALYSIS AND OPTIMIZATION

The resulting preliminary designs are subjected to the appropriate analysis to determine their suitability for the specified constraints. If these design fails to satisfy the constraints, they are then redesigned or modified on the basis of the feedback from the analysis

### 5. EVALUTION

The assessment or evaluation of the design against the specification established during the problem definition phase is then carried out. This often requires to fabrication and testing of a prototype model to evaluate operating performance quality, reliability etc.

### 6. PRESENTATION

The final phase in the design process is the presentation of the design. The include documentation of the design through drawings, materials, specification, assembly list soon

### BENEFITS OF CAD

1. Productivity Improvements in Design
2. Shorter Lead Time
3. Design Analysis
4. Failure Design Errors
5. Flexibility In Design
6. Standardization Of Design Drafting And Documentation
7. Drawings Are More Understandable

2 D View

3d View.



## 8. Improved Procedure For Engineering Changes

Easily Collect From Database

## 9. Benefits Of Manufacturing

Capp

Tool And Fixture Design

# 1.2 GEOMETRIC TRANSFORMATIONS

Geometric transformations provide a means by which an image can be enlarged in size, or reduced, rotated, or moved. These changes are brought about by changing the co-ordinates of the picture to a new set of values depending upon the requirements.

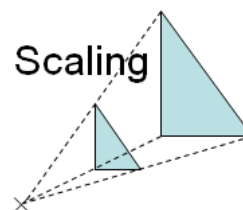
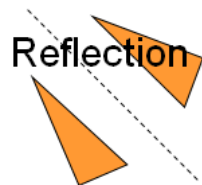
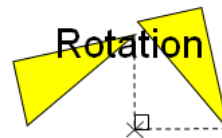
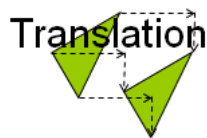
- 2 D TRANSFORMATION
- 3 D TRANSFORMATION

## 2 D TRANSFORMATIONS

Scaling, Translation, Rotation, Shearing, Reflection

### 2 D TRANSFORMATION

Scaling, Translation,  
Rotation, Shearing, Reflection



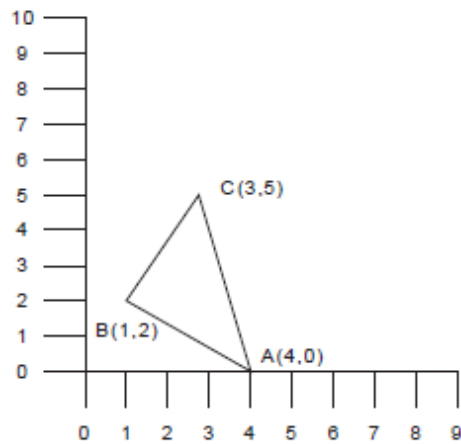
## SCALING

A drawing can be made bigger by increasing the distance between the points of the drawing. In general, this can be done by multiplying the co-ordinates of the drawing by an enlargement or reduction factor called scaling factor, and the operation is called scaling.

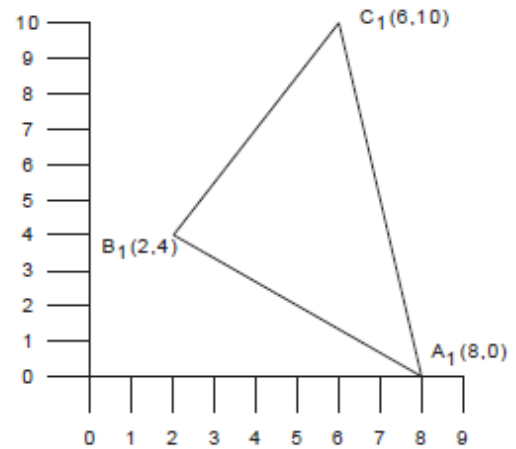
- $X'' = S_x \times X$
- $Y'' = S_y \times Y$

$$\begin{bmatrix} S_x & 0 \\ 0 & S_y \end{bmatrix}$$

where  $S_x$  and  $S_y$  are scaling factors in X and Y directions.



**Fig. 3.11 (a)**



**Fig. 3.11 (b)**

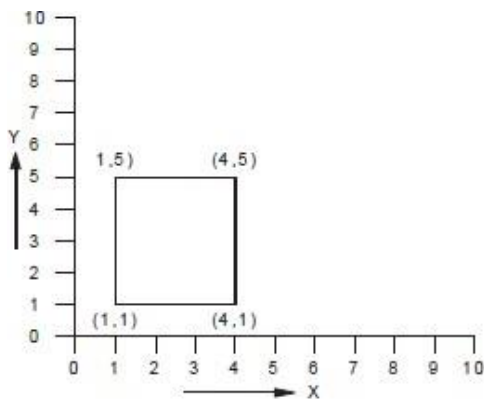
**Fig. 3.11 Scaling a Triangle**

### TRANSLATION

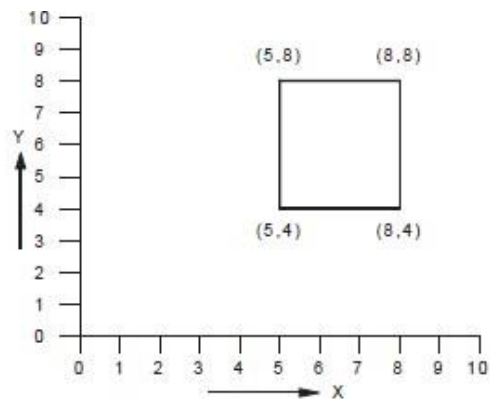
Moving drawing or model across the screen is called translation. This is accomplished by adding to the co-ordinates of each corner point the distance through which the drawing is to be moved (translated). Fig. 3.12 shows a rectangle (Fig. 3.12 (a)) being moved to a new position (Fig. 3.12 (b)) by adding 40 units to X co-ordinate values and 30 units to Y coordinate values. In general, in order to translate drawing by  $(T_x, T_y)$  every point  $X, Y$  will be replaced by a point  $X_1, Y_1$  where

$$X_1 = X + T_x$$

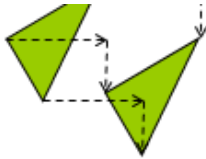
$$Y_1 = Y + T_y$$



**Fig. 3.12(a) Original Rectangle**



**Fig. 3.12 (b) Rectangle After Translation**



# Translation

Translations are usually given in vector form:

$\begin{pmatrix} 3 \\ -1 \end{pmatrix}$  means 3 units to the right  
and 1 unit down.

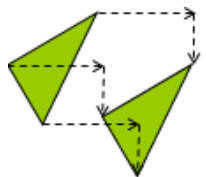
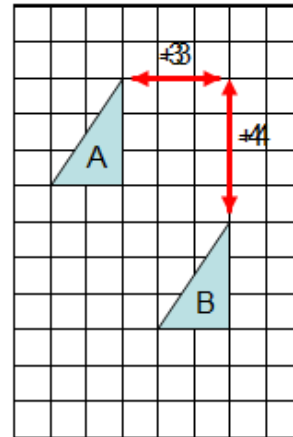
So what does  $\begin{pmatrix} -2 \\ 5 \end{pmatrix}$  mean?

What is the vector translating A to B?  
What about B to A?

A to B:  $\begin{pmatrix} 3 \\ -4 \end{pmatrix}$       B to A:  $\begin{pmatrix} -3 \\ 4 \end{pmatrix}$

After translation, a shape will be

- the same shape and size
- the same way round (orientation)
- in a different position



# Translation

Translations are usually given in vector form:

$\begin{pmatrix} 3 \\ -1 \end{pmatrix}$  means 3 units to the right  
and 1 unit down.

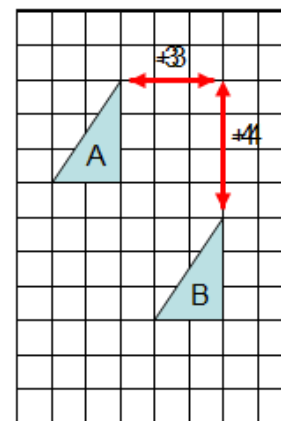
So what does  $\begin{pmatrix} -2 \\ 5 \end{pmatrix}$  mean?

What is the vector translating A to B?  
What about B to A?

A to B:  $\begin{pmatrix} 3 \\ -4 \end{pmatrix}$       B to A:  $\begin{pmatrix} -3 \\ 4 \end{pmatrix}$

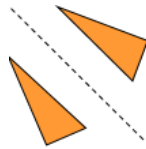
After translation, a shape will be

- the same shape and size
- the same way round (orientation)
- in a different position



## REFLECTION

- When a shape is reflected, the reflection takes place in a “line of reflection” or “mirror line”.
- To draw the reflection, first draw the mirror line.
- Now draw a perpendicular line from one corner of the original shape to the mirror line, and extend it for the same distance on the other side (as on diagram above).
- Repeat with the other corners until you can draw the whole shape.



## Reflection

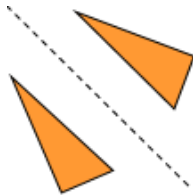
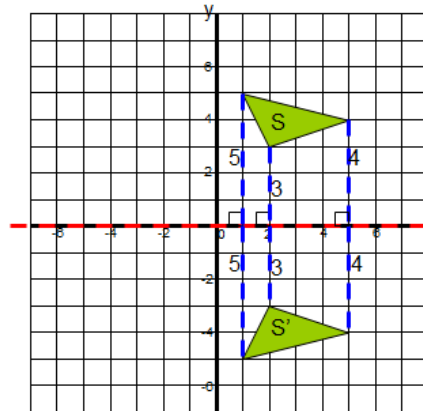
Now try reflecting shape S in the line  $y=0$ .

**Have a go before you click to continue!**

Where is the line  $y=0$ ? Hint: the points  $(0,0)$ ,  $(1,0)$ ,  $(2,0)$  etc. are all on it...  
...yes, it's the x-axis!

Now draw in your perpendicular lines...

Finally, draw in your transformed shape...



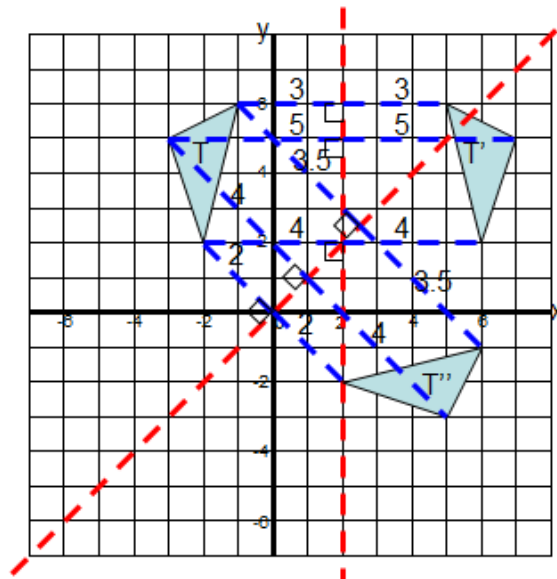
## Reflection

- Now reflect shape T in the line  $x=2$ ...

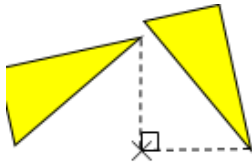
**Try it before clicking to continue!**

- ... and then reflect shape T in the line  $y=x$

**Try it before clicking to continue!**

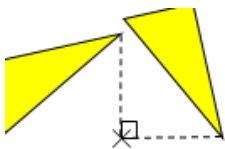


## ROTATION



## Rotation

- You need to be able to rotate a shape about a given point
  - clockwise or anticlockwise
  - through 90, 180 or 270 degrees (quarter-, half- or  $\frac{3}{4}$ -turn)
- A piece of tracing paper can make this easier!
  - Mark the centre of rotation and draw a straight line connecting it to one corner on the shape
  - Put tracing paper over both the shape AND the centre of rotation
  - Trace the shape and line onto the paper
  - Put your pencil point on the centre of rotation and turn the paper through the appropriate angle
  - Draw the transformed shape in its new position
- Let's give it a try...



## Rotation

Rotate shape A clockwise through  $90^\circ$  about the origin.

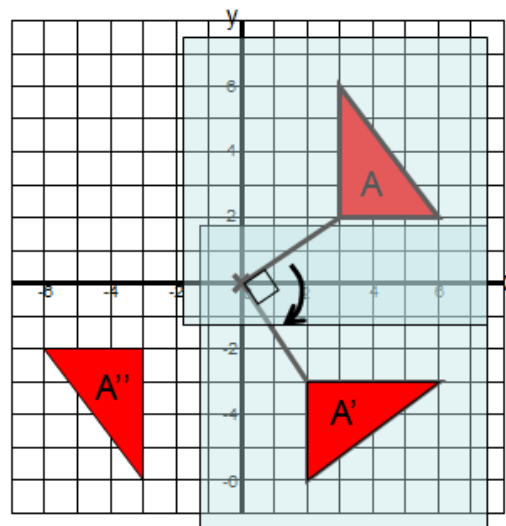
First, mark your centre of rotation at (0,0) and join it to the shape.

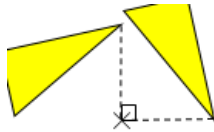
Place the tracing paper over the shape and the CoR, and trace.

With your pencil point on the CoR, rotate the tracing paper clockwise through  $90^\circ$ , then transfer the shape to its new position on the grid.

Now try rotating the same shape anticlockwise through  $180^\circ$  about the origin.

Try it, then click to see the answer.





# Rotation

Now rotate shape D anticlockwise through  $90^\circ$  about the point  $(2, -1)$ .

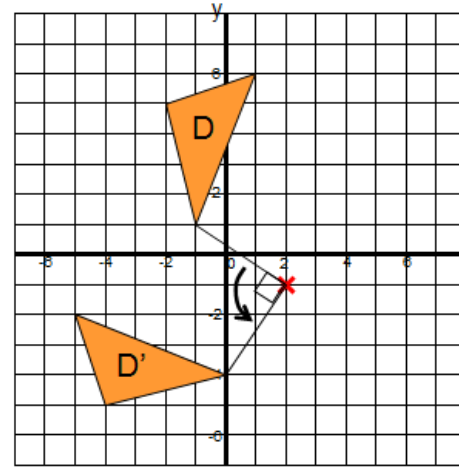
**Try it before clicking to continue!**

Can you think of another way to describe this transformation?  
Click again for the answer...

**Rotation clockwise through  $270^\circ$  about the point  $(2, -1)$**

What transformation would return the shape to its original position?

**Rotation clockwise through  $90^\circ$  (or anticlockwise through  $270^\circ$ ) about the point  $(2, -1)$**



$$\begin{bmatrix} \cos\theta & \sin\theta \\ -\sin\theta & \cos\theta \end{bmatrix}$$

The new co-ordinates are

$$= \begin{bmatrix} 40 & 20 \end{bmatrix} \begin{bmatrix} \cos 45^\circ & \sin 45^\circ \\ -\sin 45^\circ & \cos 45^\circ \end{bmatrix}$$

$$= \begin{bmatrix} 40 & 20 \end{bmatrix} \begin{bmatrix} 0.707 & 0.707 \\ -0.707 & 0.707 \end{bmatrix}$$

$$= \begin{bmatrix} 14.14 & 42.42 \end{bmatrix}$$

For rotating drawings in anticlockwise direction positive angles are used.

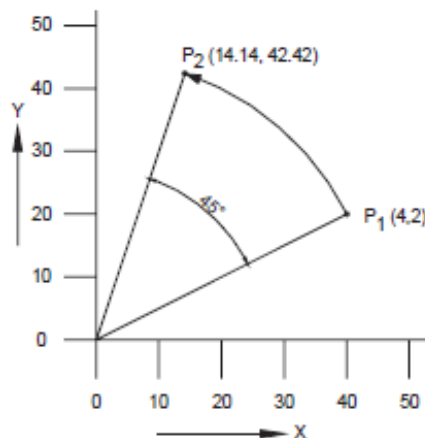


Fig. 3.13 Rotation

### 3 D transformation

It is often necessary to display objects in 3-D on the graphics screen. The transformation matrices developed for 2-dimensions can be extended to 3-D.

i. **Scaling:** The scaling matrix in 3-D is:

$$\begin{bmatrix} S_x & 0 & 0 & 0 \\ 0 & S_y & 0 & 0 \\ 0 & 0 & S_z & 0 \\ 0 & 0 & 0 & 1 \end{bmatrix}$$

ii. **Translation:** The translation matrix is:

$$\begin{bmatrix} 1 & 0 & 0 & 0 \\ 0 & 1 & 0 & 0 \\ 0 & 0 & 1 & 0 \\ T_x & T_y & T_z & 1 \end{bmatrix}$$

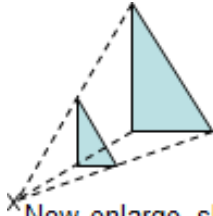
iii. **Rotation:** Rotation in 3-D can be about X - , Y - or Z axis.

Rotation about Z axis:  $R_z = \begin{bmatrix} \cos\theta & \sin\theta & 0 & 0 \\ -\sin\theta & \cos\theta & 0 & 0 \\ 0 & 0 & 1 & 0 \\ 0 & 0 & 0 & 1 \end{bmatrix}$

Similarly  $R_x = \begin{bmatrix} 1 & 0 & 0 & 0 \\ 0 & \cos\phi & -\sin\phi & 0 \\ 0 & \sin\phi & \cos\phi & 0 \\ 0 & 0 & 0 & 1 \end{bmatrix}$

similarly

and  $R_y = \begin{bmatrix} \cos\phi & 0 & \sin\phi & 0 \\ 0 & 1 & 0 & 0 \\ -\sin\phi & 0 & \cos\phi & 0 \\ 0 & 0 & 0 & 1 \end{bmatrix}$



## Enlargement

Now enlarge shape R about the point  $(-2, 1)$  with scale factor 3.

**Final question:** Clicking to continue!

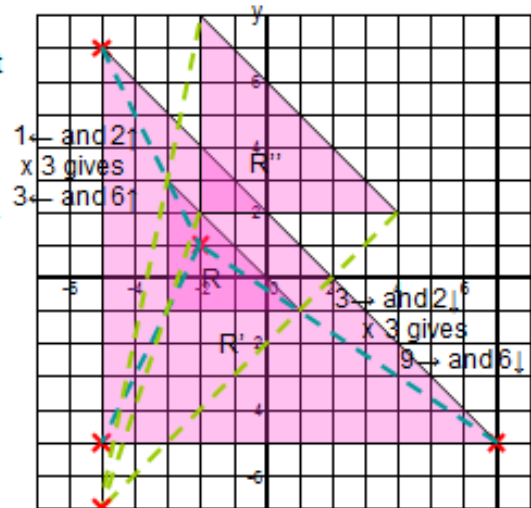
$R''$  is also an enlargement of shape R. Can you work out the scale factor and find the centre of enlargement?

Compare the side lengths:

Scale factor =  $\frac{\text{new length}}{\text{old length}}$

So scale factor =  $6/4 = 1.5$

Now draw lines through the corresponding vertices of the two shapes, and extend them back until they meet; this point is the CoE.



Centre of enlargement =  $(-6, -7)$

## 1.3 Geometric modelling

### Why Geometric modeling is needed

- Geometric (3D) models are easier to interpret.
- Simulation under real-life conditions.
- Less expensive than building a physical model.
- 3D models can be used to perform finite element analysis (stress, deflection, thermal)
- 3D models can be used directly in manufacturing, Computer Numerical Control (CNC).
- Can be used for presentations and marketing.

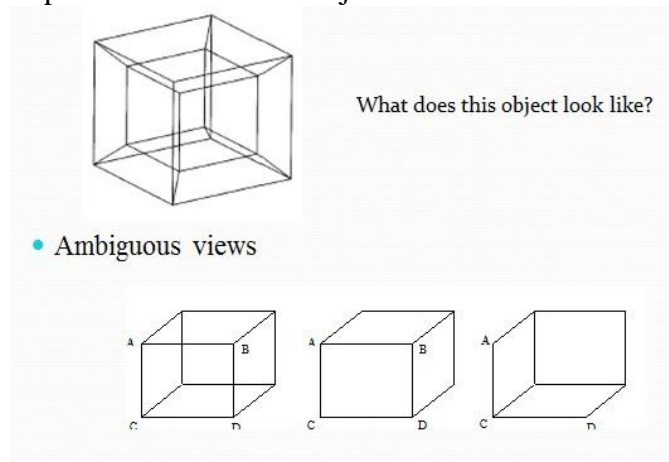
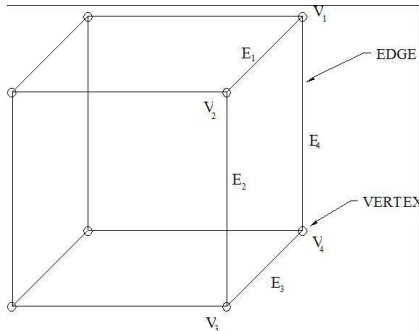
### Types of geometric modeling methods

- Wireframe modeling
- Surface modeling
- Solid modeling



## WIREFRAME MODELLING

- Wire-frame modelling uses points and curves (i.e. lines, circles, arcs) to define objects.
- The user uses edges and vertices of the part to form a 3-D object



### Advantages

- Can quickly and efficiently convey information than multi view drawings.
- Can be used for finite element analysis.
- Can be used as input for CNC machines to generate simple parts.
- Contain most of the information needed to create surface, solid and higher order models

### Disadvantages

- Tend to be not realistic
- Do not represent an actual solids (no surface and volume).
- Cannot model complex curved surfaces.
- Cannot be used to calculate dynamic properties.
- Ambiguity
  - complex model difficult to interpret.

## Surface Modeling

“ A surface model represents the skin of an object, these skins have no thickness or material type ”

- Surface modeling is more sophisticated than wireframe modeling in that it defines not only the edges of a 3D object, but also its surfaces.
- In surface modeling, objects are defined by their bounding faces.

### Advantages

- Eliminates ambiguity and non-uniqueness present in wireframe models by hiding lines not seen.
- Renders the model for better visualization and presentation, objects appear more realistic.
- Provides the surface geometry for CNC machining.
- Provides the geometry needed for mold and die design.
- Can be used to design and analyze complex free-formed surfaces (car bodies)

- Surface properties such as roughness, color and reflectivity can be assigned and demonstrated.

### Dis advantages

- Surface models provide no information about the inside of an object.
- Cannot be used to calculate dynamic properties.

### Surface Entities

#### Analytic entities include :

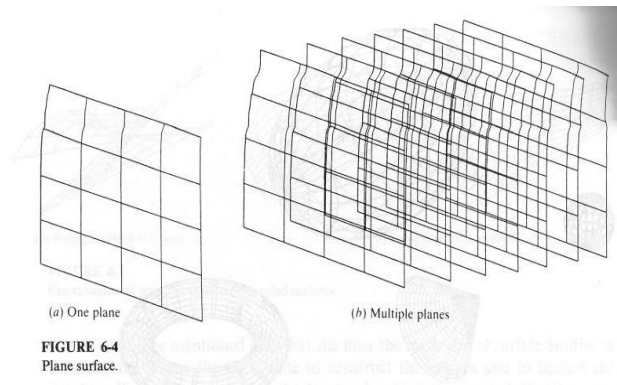
- Plane surface,
- Ruled surface,
- Surface of revolution, and
- Tabulated cylinder.

#### Synthetic entities include

- Hermite Cubic spline surface,
- B-spline surface,
- Bezier surface, and
- Coons patches.

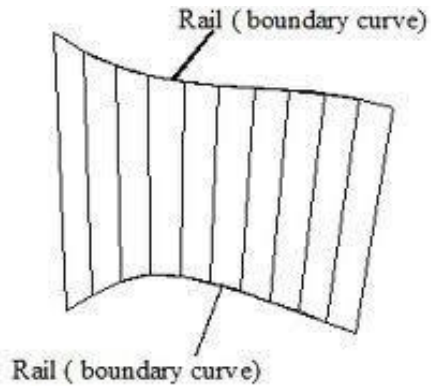
### Plane surface

- 



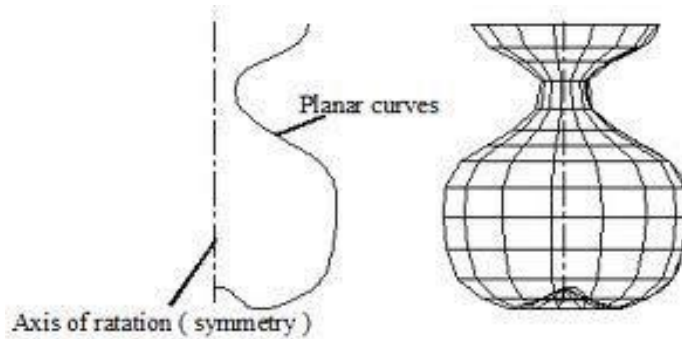
### Ruled (lofted) surface.

This is a linear surface. It interpolates linearly between two boundary curves that define the surface.



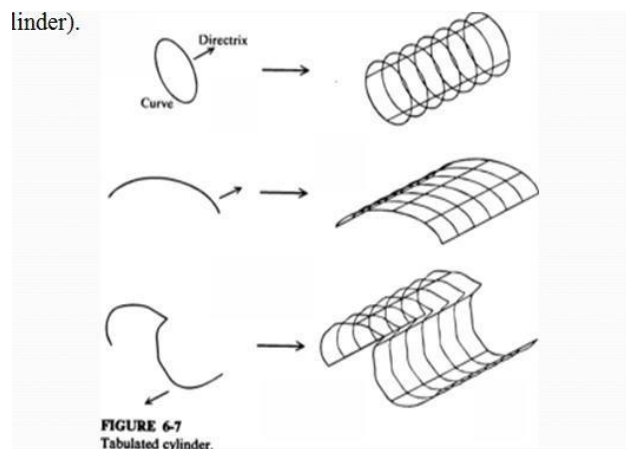
**Surface of revolution.**

This is an axisymmetric surface that can model axisymmetric objects. It is generated by rotating a planar wireframe entity in space about the axis of symmetry a certain angle.



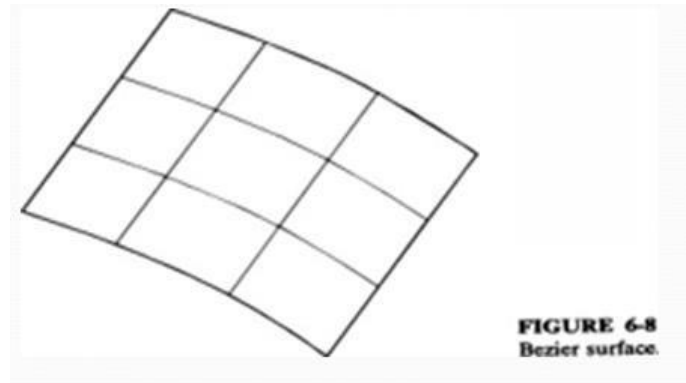
**Tabulated cylinder.**

This is a surface generated by translating a planar curve a certain distance along a specified direction (axis of the cylinder).



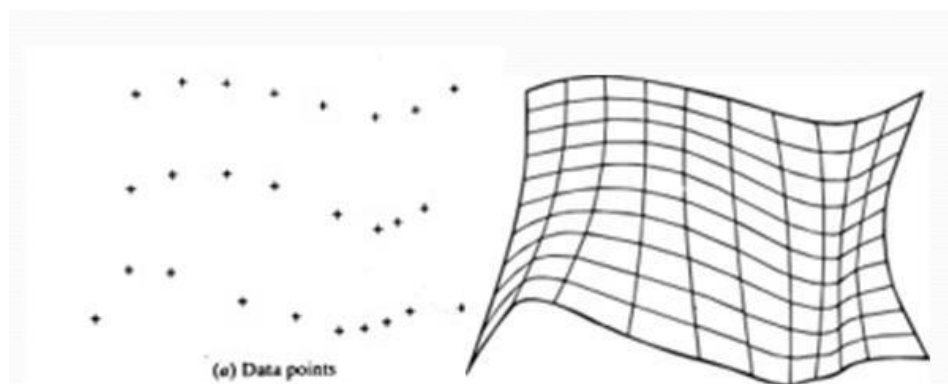
### Bezier surface.

This is a surface that approximates given input data. It is different from the previous surfaces in that it is a synthetic surface. Similarly to the Bezier curve, it does not pass through all given data points. It is a general surface that permits, twists, and kinks. The Bezier surface allows only global control of the surface.



### B-spline surface.

This is a surface that can approximate or interpolate given input data. It is a synthetic surface. It is a general surface like the Bezier surface but with the advantage of permitting local control of the surface.



- Coons patch - use standard books to read
- Fillet surface - use standard books to read
- Offset surface - use standard books to read.

### Solid Modeling

- In the solid modeling, the solid definitions include vertices (nodes), edges, surfaces, weight, and volume. The model is a complete and unambiguous representation of a precisely enclosed and filled volume



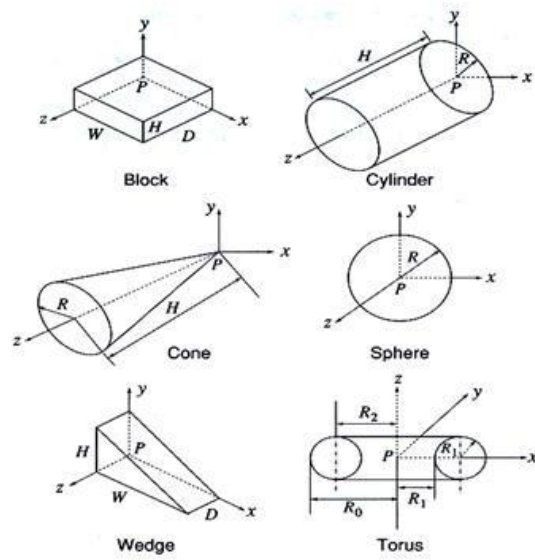
### Methods of Creating Solid Models

- Constructive Solid Geometry (CSG), CAD packages; Unigraphics, AutoCAD – 3D modeler.
- Boundary Representation (B-rep), mostly used in finite element programs.
- Parametric Modeling, CAD packages: SolidWorks, Pro/Engineer

### Primitive solids

Primitive creation functions:

- These functions retrieve a solid of a simple shape from among the primitive solids stored in the program in advance and create a solid of the same shape but of the size specified by the user



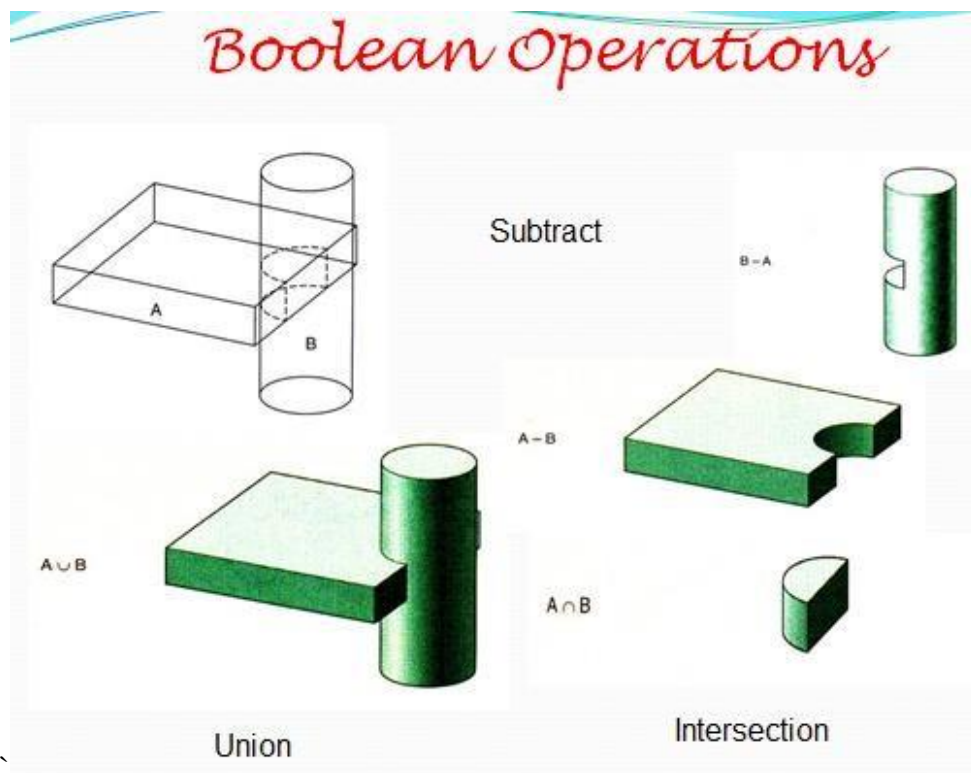
## Constructive Solid Geometry, (CSG)

- CSG defines a model in terms of combining basic and generated (using extrusion and sweeping operation) solid shapes.
- Objects are represented as a combination of simpler solid objects (*primitives*).
- CSG uses Boolean operations to construct a model.
- There are three basic Boolean operations:

**Union (Unite, join) - the operation combines two volumes included in the different solids into a single solid.**

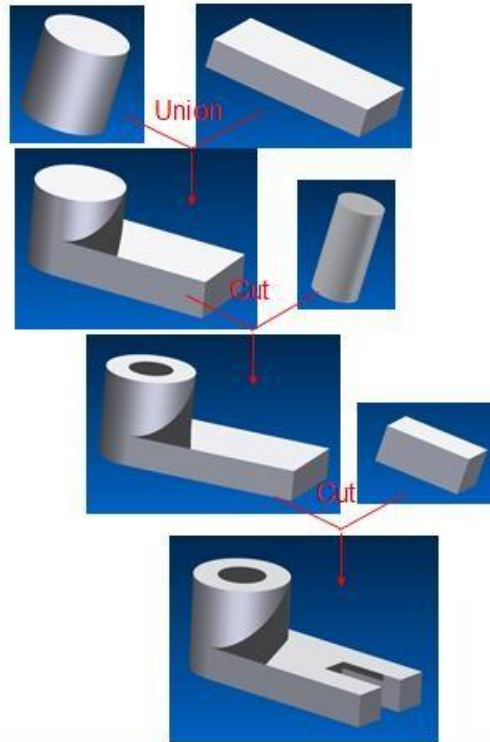
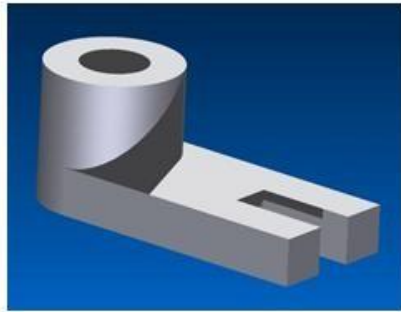
**Subtract (cut) - the operation subtracts the volume of one solid from the other solid object.**

**Intersection - the operation keeps only the volume common to both solids**



### *Solid Modeling Example Using CSG*

Plan your modeling strategy before you start creating the solid model



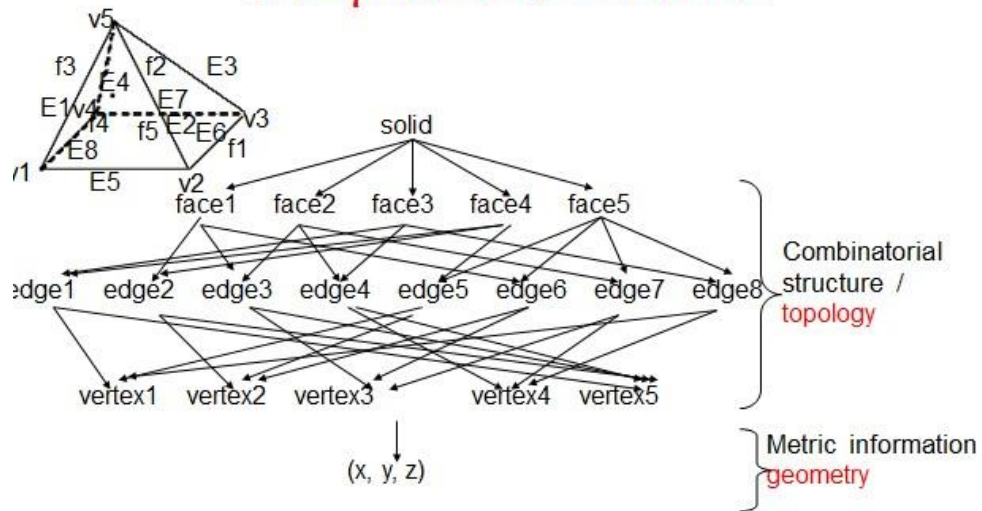
### Boundary Representation (B-rep)

- Solid model is defined by their enclosing surfaces or boundaries. This technique consists of the geometric information about the faces, edges and vertices of an object with the topological data on how these are connected.
- B-rep model is created using Euler operation
- Data structure :
  - B-Rep graph store face, edge and vertices as nodes, with pointers, or branches between the nodes to indicate connectivity.

### B-Rep data structure



## B-Rep data structure



## B-Rep data structure

Face Table		Edge Table		Vertex Table	
Face	Edges	Edge	Vertices	Vertex	Coordinates
F <sub>1</sub>	E <sub>1</sub> , E <sub>5</sub> , E <sub>6</sub>	E <sub>1</sub>	V <sub>1</sub> , V <sub>2</sub>	V <sub>1</sub>	x <sub>1</sub> , y <sub>1</sub> , z <sub>1</sub>
F <sub>2</sub>	E <sub>2</sub> , E <sub>6</sub> , E <sub>7</sub>	E <sub>2</sub>	V <sub>2</sub> , V <sub>3</sub>	V <sub>2</sub>	x <sub>2</sub> , y <sub>2</sub> , z <sub>2</sub>
F <sub>3</sub>	E <sub>3</sub> , E <sub>7</sub> , E <sub>8</sub>	E <sub>3</sub>	V <sub>3</sub> , V <sub>4</sub>	V <sub>3</sub>	x <sub>3</sub> , y <sub>3</sub> , z <sub>3</sub>
F <sub>4</sub>	E <sub>4</sub> , E <sub>8</sub> , E <sub>5</sub>	E <sub>4</sub>	V <sub>4</sub> , V <sub>1</sub>	V <sub>4</sub>	x <sub>4</sub> , y <sub>4</sub> , z <sub>4</sub>
F <sub>5</sub>	E <sub>1</sub> , E <sub>2</sub> , E <sub>3</sub> , E <sub>4</sub>	E <sub>5</sub>	V <sub>1</sub> , V <sub>5</sub>	V <sub>5</sub>	x <sub>5</sub> , y <sub>5</sub> , z <sub>5</sub>
		E <sub>6</sub>	V <sub>2</sub> , V <sub>5</sub>	V <sub>6</sub>	x <sub>6</sub> , y <sub>6</sub> , z <sub>6</sub>
		E <sub>7</sub>	V <sub>3</sub> , V <sub>5</sub>		
		E <sub>8</sub>	V <sub>4</sub> , V <sub>5</sub>		

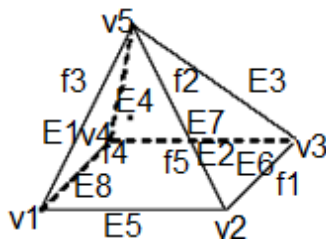
### Boundary representation- validity

- System must validate topology of created solid.
- For topology consistency, certain rules have to be followed
- Faces should be bound by a simple loop of edges and should be not intersected by itself.
- Each edge should exactly adjoin two faces and each edge should have a vertex at each ends.
- At least three edges should meet at each vertex.



## Boundary representation- validity

- Validity also checked through mathematical evaluation
  - Evaluation is based upon Euler's Law (valid for simple solid – no hole)
  - $V - E + F = 2$       V- number of vertices  
E- number of edges  
F- number of faces

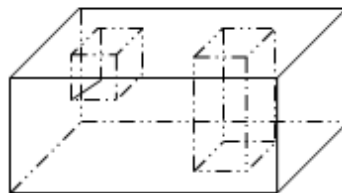


$$V = 5, \quad E = 8, \quad F = 5$$

$$5 - 8 + 5 = 2$$

## Boundary representation- validity

- Expanded Euler's law for complex polyhedrons (with holes)
- Euler-Poincare Law:
  - $V - E + F - H + 2P = 2B$
  - H – number of holes in face, P- number of passages or through holes, B- number of separate bodies.



$$V = 24, \quad E = 36, \quad F = 15, \quad H = 3, \quad P = 1, \quad B = 1$$

### Operation performed

- (Extrude Feature, Revolve Feature, Sweep, Loft, Fillet, Chamfer) (**Refer standard books**).

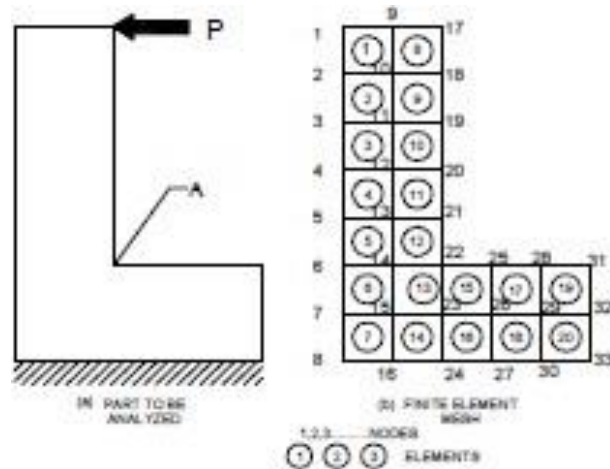
# 1.4 Finite element analysis

## HISTORY OF FEA

- FEA was initially developed in 1943 by R. Courant to obtain approximate solution to vibration problems.
- Turner et al published in 1956 a paper on “Stiffness and Deflection of Complex Structures”.

## WHAT IS FINITE ELEMNT METHOD ?

- The finite element method is a numerical procedure. This method involves modeling the structure using a finite number of small interconnected elements. Consider the plate shown in Fig.



*Fig. 7.1 Finite Element Modeling*

## GENERAL STEPS INVOLVED IN FINITE ELEMENT ANALYSIS

### STEP 1. SELECT THE ELEMENT TYPE AND DISCRETIZE THE COMPONENT

The first step is to select an element which closely represents the physical behavior of the structure. The size of the elements to start with is a matter of judgment of the designer.

### STEP 2 . SELECT A DISPLACEMENT FUNCTION

A displacement function within the element using the nodal values of the element is then defined. These may be linear, quadratic or cubic polynomials. The same displacement function is used for all the elements. Hence in the finite element model a continuous quantity like displacement is approximated by a discrete model composed of a set of piece wise continuous functions defined in each finite element.

### STEP 3. DEFINE STRESS STRAIN RELATIONSHIP

Definition of stress strain relationship for each element is the next step. For example in the case of one dimensional deformation, if u is the displacement in the direction X, the strain is related to the displacement by the relation

$$\epsilon_x = du/dx$$

The stresses are related to the strains through the stress strain law or constitutive law. Using Hooke's law, the stress strain law can be written as:

$$\sigma_x = E\epsilon_x$$

where  $\sigma$  is the stress in the X direction and E is the modulus of elasticity.

#### STEP 4. DERIVE THE ELEMENT STIFFNESS MATRIX

The stiffness matrix could be derived by the direct equilibrium method or work or energy method or method of weighted residuals. In direct equilibrium method the stiffness matrix and the element equations related to nodal forces are obtained using force equilibrium conditions

$$\begin{Bmatrix} f_1 \\ f_2 \\ f_3 \\ - \\ - \\ f_n \end{Bmatrix} = \begin{bmatrix} k_{11} & k_{12} & k_{13} & - & k_{1n} \\ k_{21} & k_{22} & k_{23} & - & - \\ k_{31} & k_{32} & - & - & - \\ - & - & - & - & - \\ - & - & - & - & - \\ k_{n1} & - & - & - & k_{nn} \end{bmatrix} \begin{Bmatrix} d_1 \\ d_2 \\ d_3 \\ - \\ - \\ d_n \end{Bmatrix}$$

This may also be written in the form  $\{f\} = [k] \{d\}$  where  $\{f\}$  is the vector of element nodal forces,  $[k]$  is the element stiffness matrix and  $\{d\}$  is the displacement vector.

#### STEP 5. ASSEMBLE GLOBAL STIFFNESS MATRIX

The individual element stiffness matrices are then assembled to obtain the global stiffness matrix of the whole component being analyzed.

#### STEP 6. SOLVE TO OBTAIN NODAL DISPLACEMENTS

Solve the below equation to get displacement values

$$[F] = [K][d]$$

## STEP.7. SOLVE FOR ELEMENT STRAINS AND STRESSES

Strains can be computed from the displacements. Once the strain is known the stress can be calculated using Hooke's law. Principal stresses, shear stresses, von Mises stresses (equivalent stress) etc. could be computed depending on the interest of the designer.

### TYPES OF ANALYSIS

- STRUCTURAL ANALYSIS (STATIC AND DYNAMIC ANALYSIS)
- LINEAR AND NON-LINEAR ANALYSIS
- THERMAL ANALYSIS
- FLUID FLOW ANALYSIS
- FIELD ANALYSIS (ELECTRICAL, MAGNETIC, ELECTROMAGNETIC AND ELECTROSTATIC)

### ONE MARKS:

1) In computer aided drafting practice, an arc is defined by

- (a) Two end points only
- (b) Center and radius
- (c) Radius and one end point
- (d) Two end points and center

Ans: D

2) In the following geometric modelling techniques which are not three-dimensional modelling?

- (a) Wireframe modelling
- (b) Drafting
- (c) Surface modelling
- (d) solid modelling

Ans: B

3) In the following three-dimensional modelling techniques. Which do not require much computer time and memory?

- (a) Surface modelling
- (b) Solid modelling
- (c) Wireframe modelling
- (d) All of the above

Ans: C

4) In the following geometric primitives, which is not a solid entity of CSG modelling?

- (a) Box
- (b) Cone
- (c) Cylinder
- (d) Circle

Ans: D

5) The number of lines required to represent a cube in a wireframe model is?

- (a) 8 (b) 6 (c) 12 (d) 16

Ans: C

6) Which of the following is not an analytical entity?

- (a) Line (b) Circle (c) Spline (d) Parabola

Ans: C

7) Which of the following is not a synthetic entity?

- (a) Hyperbola (b) Bezier curve (c) B-spline curve (d) Cubic spline curve

Ans: A

8) The number of tangents required to describe cubic splines is?

- (a) 2 (b) 1 (c) 3 (d) 4

Ans: B

9) The shape of the Bezier curve is controlled by ?

- (a) Control points (b) Knots (c) End points (d) All the above

Ans: A

10) The curve that follows a convex hull property is ?

- (a) Cubic spline (b) B-spline (c) Bezier curve (d) Both (b) and (c)

Ans: B

11) The curve that follows a convex hull property is ?

- (a) Cubic spline (b) B-spline (c) Bezier curve (d) Both (b) and (c)

Ans: B

12) The degree of the Bezier curve with n control points is ?

(a)  $n + 1$  (b)  $n - 1$  (c)  $n$  (d)  $2n$

Ans: A

13) The degree of the B-spline with varying knot vectors ?

(a) Increases with knot vectors (b) Decreases with knot vectors (c) Remains constant (d) none of the above

Ans: A

14) The degrees of freedom of a two-node bar element are ?

(a) 1 (b) 2 (c) 3 (d) 4

Ans: C

15) In a 2-D CAD package, clockwise circular arc of radius, 5, specified from P1 (15, 10) to P2 (10, 15) will have its center at?

(a) (10, 10)

(b) (15, 10)

(c) (15, 15)

(d) (10, 15)

Ans: A

16) Stiffness is \_\_\_\_\_ to the length of the element.

(a) Inversely proportional

(b) Directly proportional

(c) Exponential

(d) Independent

Ans: D

17) The degrees of freedom of a two-node bar element are ?

(a) 1 (b) 2 (c) 3 (d) 4

Ans: C

18) The UCS icon represents the intersection of the\_\_\_\_\_.

(a) X-axis

(b) Y-axis

- (c) Z-axis
- (d) All the above

## TWO MARKS

1) Describe Computer Aided Design?

CAD is the function of computer systems to support in the creation, modification, analysis, or optimization of a design. CAD software is used to raise the productivity of the designer, progress the quality of design, progress communications through documentation, and to generate a database for manufacturing.

2) List out the international organizations involved developing the graphics standards?

ACM (Association for Computer Machinery)

ANSI (American National Standards Institute)

ISO (International Standards Organization)

GIN (German Standards Institute)

3) List out the various standards in graphics programming?

IGES (Initial Graphics Exchange Specification)

DXF (Drawing / Data Exchange Format)

STEP (Standard for the Exchange of Product model data)

4) Define IGES, DXF and STEP

IGES (Initial Graphics Exchange Specification) enables an exchange of model data basis among CAD system

DXF (Drawing / Data Exchange Format) file format was meant to provide an exact representation of the data in the standard CAD file format.

STEP (Standard for the Exchange of Product model data) can be used to exchange data between CAD, Computer Aided Manufacturing (CAM) , Computer Aided Engineering (CAE) , product data management/enterprise data modeling (PDES).

5) Write down the names of different software used in design?

1. AutoCAD

2. Ansys
3. Pro-Engineer
4. Catia
5. Unigraphics
6. Solidedge classic-290
7. Solidworks.

6) Explain the various steps of design process using CAD?

Traditional design process includes following six phases:-

- (i) Recognition of need.
- (ii) Definition of the problem.
- (iii) Synthesis.
- (iv) Analysis and optimization.
- (v) Evaluation.
- (vi) Presentation.

In CAD process last 4 phases of traditional design process are replaced by the following phases

- (i) Geometric modeling.
- (ii) Engg. Analyst.
- (iii) Design review and evaluation.
- (iv) Automated drafting.

7) What are the Benefits of CAD?

- a) Productivity improvement in design
- b) Shorter leads time
- c) Design analysis
- d) Fewer design error
- e) Flexibility design
- f) Standardization of design, drafting and documentation
- g) Drawings are more understandable.



### 8) What is Transformation in CAD?

Geometric transformations provide a means by which an image can be enlarged in size, or reduced, rotated, or moved. These changes are brought about by changing the co-ordinates of the picture to a new set of values depending upon the requirements. Transformations can be carried out either in 2-dimensions or in 3-dimensions.

### 9) Define scaling, translation and rotation?

- Scaling is a drawing can be made bigger by increasing the distance between the points of the drawing.

$$x''=xS_x \text{ and } y''=yS_y$$

Scaling factor  $S_x$  scale objects in the x direction while  $S_y$  scale in the y direction.

- Translation is applied to an object by repositioning it along a straight line path from one coordinate location to another.
- Rotation is applied to an objects by re positioning it along a circular path in the xy plane.to generate a rotation, we specify a rotation angle  $\theta$  and the position (x,y) of the rotation point about which the object is to be rotated.

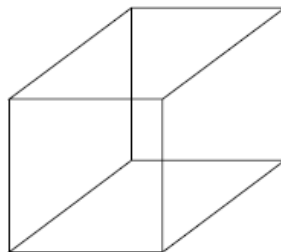
### 10) Describe Geometric modeling?

Computer representation of the geometry of a component using software is called a geometric model. Geometric modeling is done in three principal ways. They are:

- i. Wire frame modeling
- ii. Surface modeling
- iii. Solid modeling

### 11) What is wire frame modeling?

In wire frame modeling the object is represented by its edges. In the initial stages of CAD, wire frame models were in 2-D. Subsequently 3-D wire frame modeling software was introduced. The wire frame model of a box is shown in Fig.

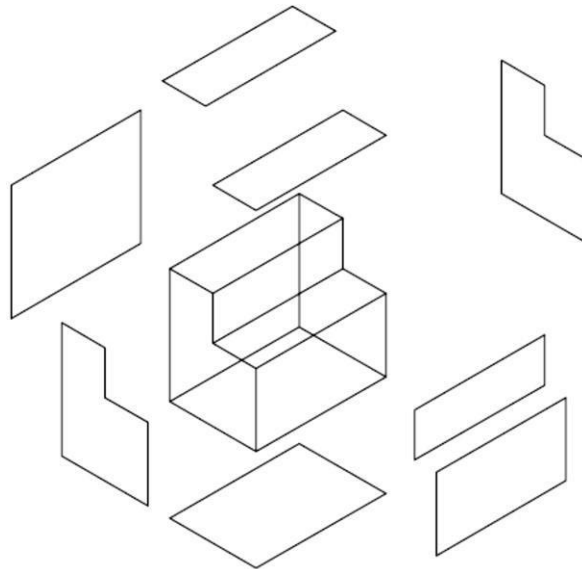


12) Compare 2 D wireframe models and 3D wireframe models?

<b>2-D Models</b>	<b>3-D wireframe Models</b>
Ends(vertices) of lines are represented by their X and Y coordinates	Ends of lines are represented by their X,Y and Z coordinates
Curved edges are represented by circles, ellipse, splines etc. Additional view and sectional views are necessary to represent a complex object with clarity	Curved surfaces are represented by suitably spaced generators. Hidden line or hidden surface elimination is a must to interpret complex components correctly.
3-D image reconstruction is tedious	2-d views as well as various pictorial views can be generated easily.
Use only one global coordinate system	May require the use of several user coordinate systems to create features on different faces of the component

13) What is surface modeling?

In this approach, a component is represented by its surfaces which in turn are represented by their vertices and edges. For example, eight surfaces are put together to create a box, as shown in Fig. Surface modeling has been very popular in aerospace product design and automotive design. Surface modeling has been particularly useful in the development of manufacturing codes for automobile panels and the complex doubly curved shapes of aerospace structures and dies and moulds.



14) Write down the advantages of surface modeling?

1. Surface modeling can be used to check the real look of the product with coloring and shading.
2. Surface modeling can be used to perform interference checking.
3. As the surface models precisely define the part geometry such as surface and boundaries, they can help to produce machine instructions automatically.
4. Complex surface features can be created very easily.
5. Un ambiguities in the interpretation of object is less than wire frame models by using the provision of hidden line removal.

15) Describe solid modeling?

The representation of solid models uses the fundamental idea that a physical object divides the 3-D Euclidean space into two regions, one exterior and one interior, separated by the boundary of the solid. Solid models are:

- Bounded
- Homogeneously three dimensional
- Finite

16) Discuss six common representations in solid modeling?

**i. Spatial Enumeration:** In this simplest form of 3D volumetric raster model, a section of 3D space is described by a matrix of evenly spaced cubic volume elements called voxels.

**ii. Cell Decomposition:** This is a hierarchical adaptation of spatial enumeration. 3D space is subdivided into cells. Cells could be of different sizes. These simple cells are glued together to describe a solid object.

**iii. Boundary Representation:** The solid is represented by its boundary which consists of a set of faces, a set of edges and a set of vertices as well as their topological relations.

**iv. Sweep Methods:** In this technique a planar shape is moved along a curve. Translational sweep can be used to create prismatic objects and rotational sweep could be used for axisymmetric components.

**v. Primitive Instancing:** This modeling scheme provides a set of possible object shapes which are described by a set of parameters. Instances of object shape can be created by varying these parameters.

**vi. Constructive Solid Geometry (CSG):** Primitive instances are combined using Boolean set operations to create complex objects.

17) What is CGS?

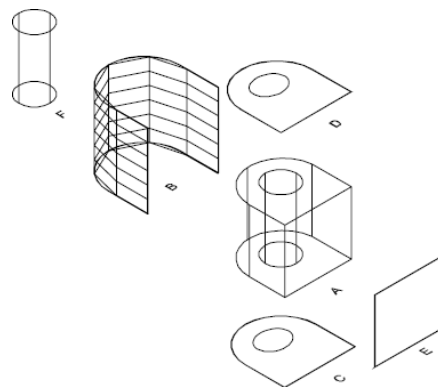
Constructive solid geometry (CSG) is a method used in solid modeling for creating 3D models in CAD. Constructive solid geometry permits a modeler to make a complex surface by applying Boolean operators to join objects. Frequently CSG presents a model/surface that appears visually complex, but is essentially little more than cleverly combined.

18) What is B-rep?

Boundary representation is built on the concept that a physical object is enclosed by a set of faces which themselves are closed and orientable surfaces. Fig.1 shows a B-rep model of an object. In this model, face is bounded by edges and each edge is bounded by vertices.

The entities which constitute a B-rep model are:

<b>Geometric entities</b>	<b>Topological entities</b>
Point	Vertex
Curve, line	Edge
Surface	Face



19) Write down two important solid modeling techniques?

The solid modeling techniques permit for the automation of some complicated engineering calculations that are approved as a part of the design progression. Simulation, planning, and confirmation of processes such as machining and assembly were one of the initiations for the development of solid modeling technique.

20) Limitations of analytical technique used in design analysis?

i. Stresses and strains are obtained only at macro level. This may result in inappropriate deployment of materials. Micro level information is necessary to optimally allocate material to heavily stressed parts.

ii. Adequate information will not be available on critically stressed parts of the components.

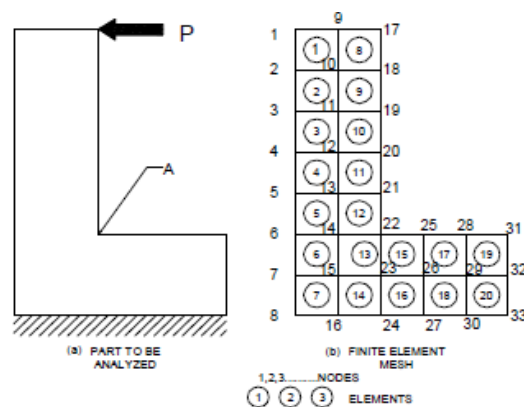
iii. It may be necessary to make several simplifications and assumptions to design complex components and systems, if design analysis is carried out in the conventional manner.

iv. Manual design is time consuming and prone to errors.

v. Design optimization is tedious and time consuming.

21) Explain finite element method?

The finite element method is a numerical procedure. This method involves modeling the structure using a finite number of small interconnected elements. Consider the plate shown in Fig. Suppose that it is acted upon by a force  $P$  as shown and our interest is to determine the stresses in the plate. The plate is discretized into 20 of elements and 33 nodes as shown in Fig.



22) What are the general steps involved in finite element analysis?

- i. Select the element type and discretize the component
- ii. Select a displacement function
- iii. Define stress strain relationship
- iv. Derive the element stiffness matrix
- v. Assemble global stiffness matrix
- vi. Solve to obtain nodal displacements
- vii. Solve for element strains and stresses

### **Big questions**

1) [Briefly explain about shigley design process?](#)

2) Write short notes on: CAD, CAD process, components of CAD system, and advantages of CAD systems.

3) [Explain the concepts of translation, scaling and rotation in 2-D transformation and 3-d transformation with examples.](#)

4) Briefly explain geometric modeling technique?

5) Discuss 1) [solid modeling](#) 2) [B-rep](#) 3) C-rep 4) sweep methods.

6) [Briefly explain wireframe model technique with its example?](#)

7) [Briefly explain surface modeling technique with example?](#)

8) [Discuss general steps involved in FEA?](#)

9) Write short notes on 1) [Bezier curve](#) 2) cubic spline?

<b>UNIT-II</b>	<b>CNC MACHINE TOOLS AND COMPONENTS</b>	<b>9</b>
Numerical control – development of NC – DNC – CNC and adaptive control systems – Distinguishing features of turning and machining center – design considerations of NC machine tools. CNC EDM machine – Coordinate measuring machines: construction, working principles and specifications – maintenance of CNC machines. Recirculating ball screw, linear motion guide ways, tool magazines, ATC, APC, chip conveyors, tool turrets		

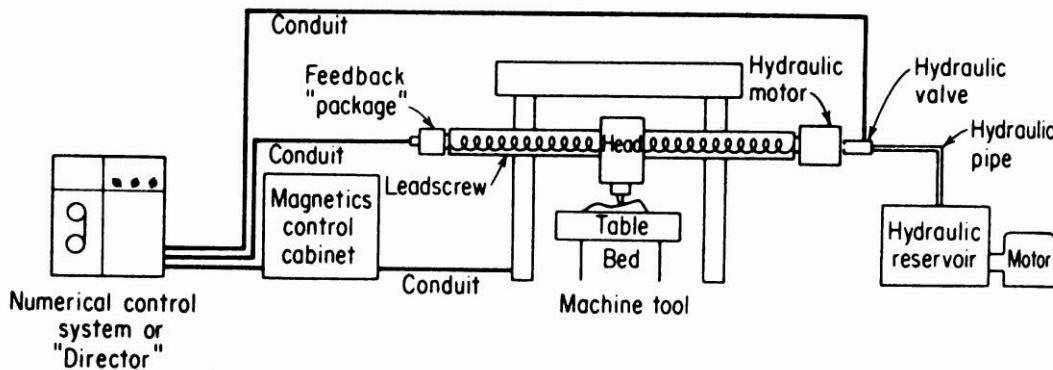
## UNIT-II CNC MACHINE TOOLS AND COMPONENTS

### Numerical control

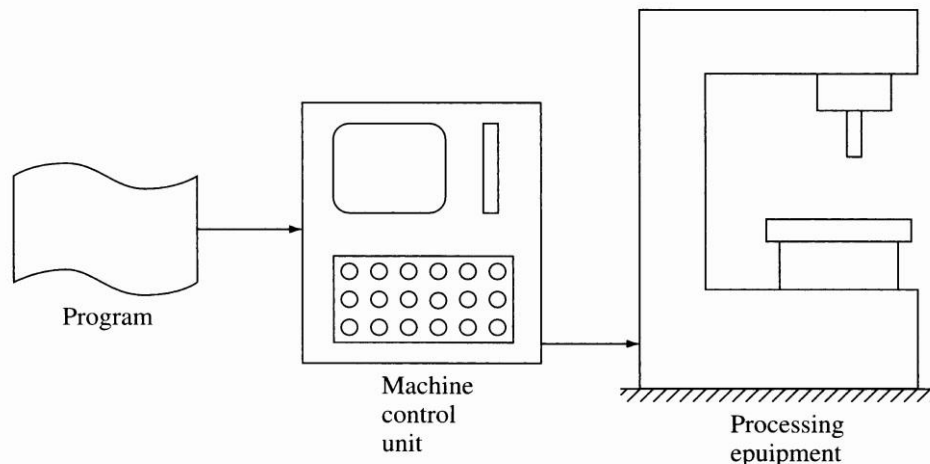
- Numerical control (NC) is a form of flexible (programmable) automation in which the process is controlled by numbers, letters, and symbols.
- The electronic industries association (EIA) defined NC as
- “A system in which actions are controlled by the direct insertion of numerical data at some point. The system must automatically interpret at least some portion of this data.”

### Basic Components

- An NC system consists of the machine tools, the part-program, and the machine control unit



*Tape-programmed NC machine*



Basic components of an NC system

### The EIA definition of computer numerical control (CNC)

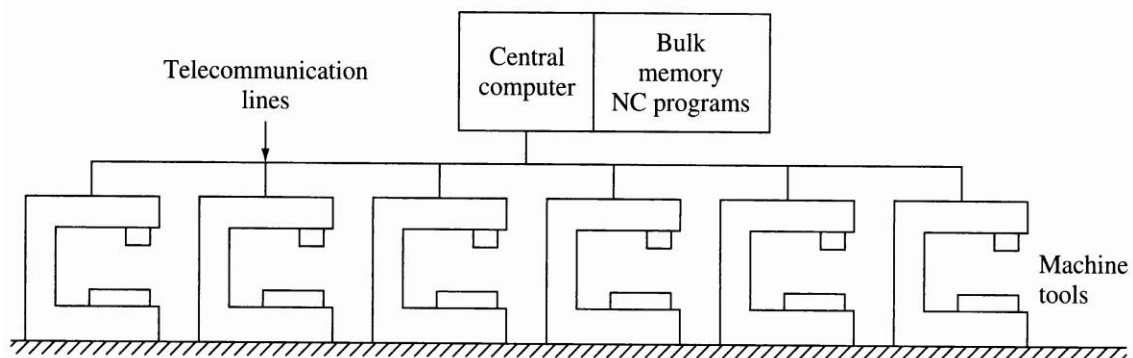
- A numerical control system wherein a dedicated, stored program computer is used to perform some or all of the basic numerical control functions in accordance with control programs stored in the read-write memory of the computer.
- CNC supports programming features not available in conventional NC systems:
  - Subroutine macros which can be stored in memory and called by the part-program to execute frequently-used cutting sequence.
  - Inch-metric conversions, sophisticated interpolation functions (such as cubic interpolation) can be easily accomplished in CNC.
  - Absolute or incremental positioning (the coordinate systems used in locating the tool relative to the work piece) as well as PTP or contouring mode can be selected.
  - The part-program can be edited (correction or optimization of tool path, speeds, and feeds) at the machine site during tape tryout.
  - Tool and fixture offsets can be computed and stored.
  - Tool path can be verified using graphic display.
  - Diagnostics are available to assist maintenance and repair.

### Direct Numerical Control (DNC)

#### The EIA definition of DNC

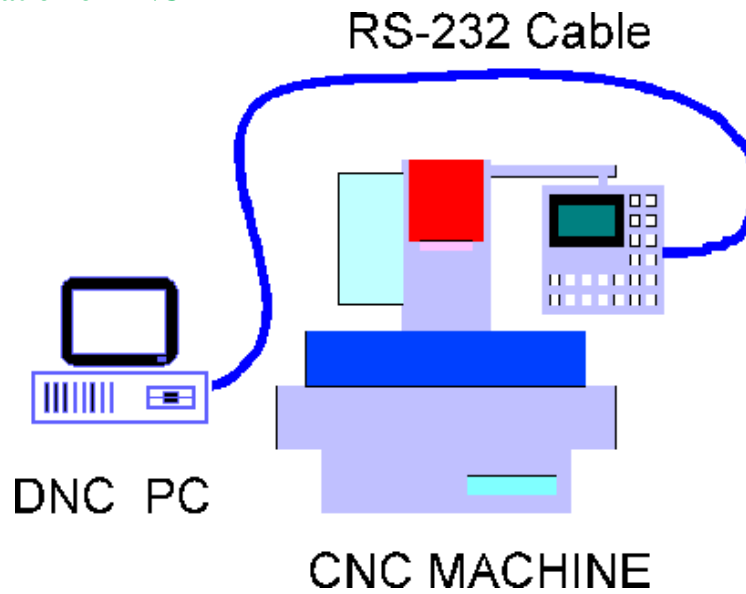
- ❖ “A system connecting a set of numerically controlled machines to a common memory for part program or machine program storage with provision for on-demand distribution of data to machines.”
- ❖ In DNC, several NC machines are directly controlled by a computer, eliminating substantial hardware from the individual controller of each machine tool. The part-program is downloaded to the machines directly (thus omitting the tape reader) from the computer memory.

*DNC machine*

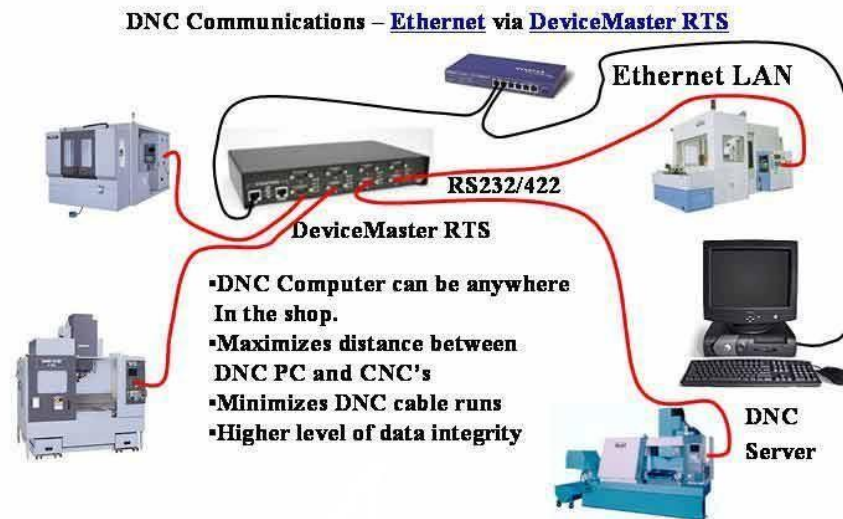




Minimal configuration of DNC



Wired DNC



DESIGN CONSIDERATION OF CNC MACHINE

1-Design considerations for structure of CNC machine tool.

- Best stiffness to weight ratio
- Damping to take care of vibrations
- Ribs at strategic locations
- Use of welded steel structure

## 2-Spindle design

- Consideration for deflection due to large cutting force
- Heat dissipation
- Positioning of gearbox, spindle motor etc

## 3-Spindle drives and feed drives

- Speed control
- Constant torque supply

## 4-Actuation systems

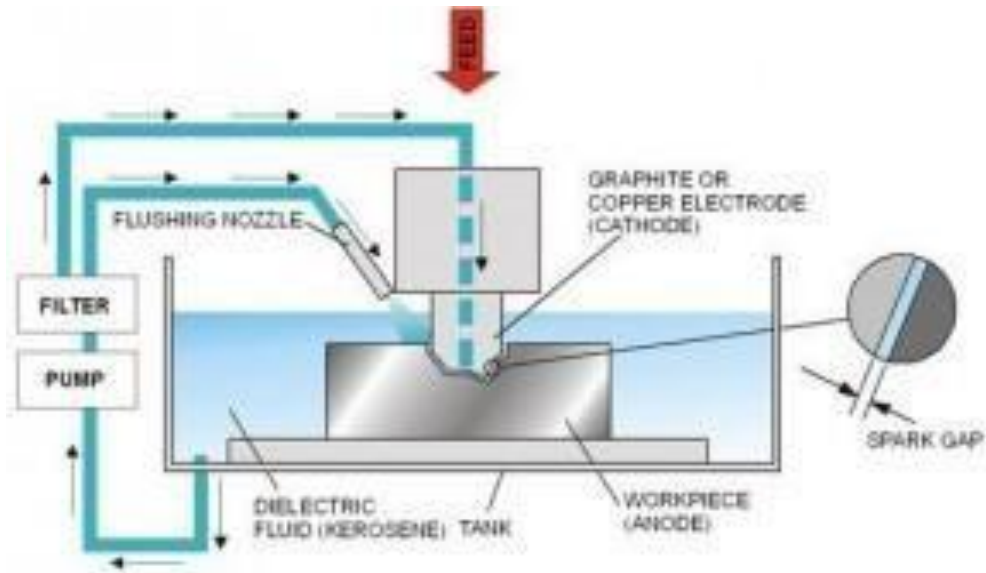
- Lead screw
- Slideways

## 5-Feedback devices

- Encoders
- Linear scales

## Electrical Discharge Machining [EDM]

- **Electrical discharge machining** is versatile among all electrical machining methods. **EDM** is most precise production procedure for creating complicated or elementary shapes, geometrics components and assemblies. Alloys that are employed in aeronautics is also machined conveniently by this procedure. This process has added advantages of being capable of machining complicated components.
- This machining method comprises a dielectric medium, tool, a source power supply of voltage 50-450v, speed reduction gear-box, a rack and pinion and an electric circuit. The job is connected to the positive terminal of source, it acts as anode and the tool which is connected to negative terminal acts as cathode. Both work and tool are split having a small range known as spark gap. When appropriate amount of current is passed between the tool and job, a dielectric solution, which occupies gap causes to breakdown.
- As a result, electrons initiate to flow from cathode to fill and ionize the gap. An electrical breakdown takes place where there is a consistent drop in resistance and discharge of electrical energy. An electric spark with appropriate force and velocity hits surface of the job. Thus, a very high temperature of about 10,000 is generated on the spot of hit by electric spark discharge and this completes the cycle in few micro seconds. This high temperature melts the metal as well as vaporizes it. The melted or vaporized particles of metal are thrown into the gap by electro magnetic and electrostatic forces and are finally driven away by dielectric flowing liquid.



## ELECTRIC DISCHARGE MACHINING

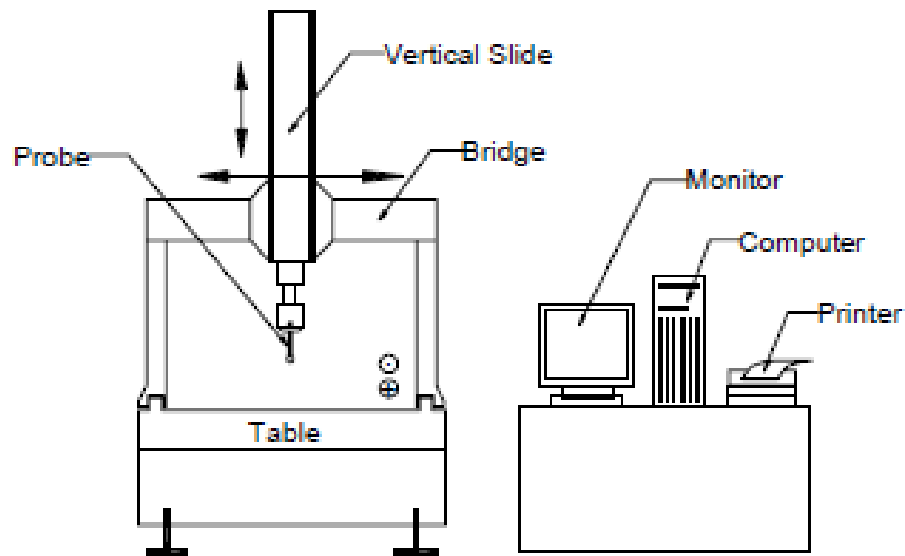
- During machining, the work pieces isn't lead through any physical deformation as there is no contact between tool and the job. This makes the procedure more versatile. Consequently, slender and fragile careers could be produced easily. The surface produced by **EDM** contain a multitude of small craters. This may help in oil retention and better lubrication, specially for components where lubrication is a problem. Electrical discharge machining process can be automated easily requiring very little attention for the machine operator.

## 2.2 COORDINATE MEASURING MACHINE (CMM)



### COORDINATE MEASURING MACHINE

- ❖ The coordinate measuring machine (CMM) is the most prominent example of the equipment used for contact inspection of parts. When used for CIM these machines are controlled by CNC.
- ❖ A typical three-dimensional measuring machine consists of a table, which holds the part in a fixed, position, and movable head, which holds a sensing, probe. The probe can be moved in three directions corresponding to the X, Y and Z Coordinates.
- ❖ For manual operation, the control unit is provided with joysticks, or other devices which drive X, Y and Z servo motors (AC/DC). During operation, the probe is brought into contact with the part surface to be measured and the three co-ordinate positions are indicated to a high level of accuracy.
- ❖ Typical accuracies of these machines are in the neighborhood of  $+ 0.004$  mm with a resolution of  $0.001$  mm. The measuring accuracy of a typical CMM is quoted  $2.6 + L/300$  micrometers, where L is the measured length in mm.



**Fig. 14.1 CNC CMM**

✓ The major features of a CMM are:

**(i) Stationary granite measuring table:** Granite table provides a stable reference plane for locating parts to be measured. It is provided with a grid of threaded holes defining clamping locations and facilitating part mounting. As the table has a high load carrying capacity and is accessible from three sides, it can be easily integrated into the material flow system of CIM.

**(ii) Length measuring system:** A 3-axis CMM is provided with digital incremental length measuring system for each axis.

**(iii) Air bearings:** The bridge, cross beam and spindle of the CMM are supported on air bearings with high rigidity. They are designed insensitive to vibrations.

**(iv) Control unit:** The control unit allows manual measurement and self teach programming in addition to CNC operation. The control unit is microprocessor controlled. Usually a joystick is provided to activate the drive for manual measurement. CNC Measuring Centres are provided with dynamic probe heads and a probe changing system, which can be operated manually or automatically.

**(v) Software:** The CMM, the computer and the software together represent one system whose efficiency and cost effectiveness depend to a large extent on the software.

**The features of CMM software will include:**

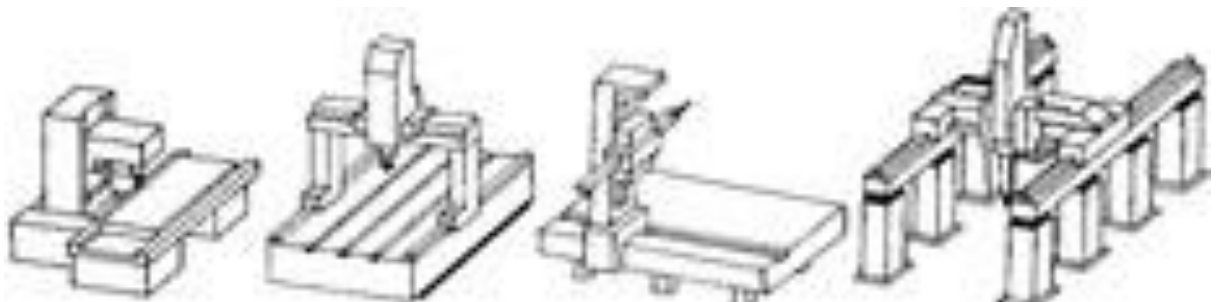
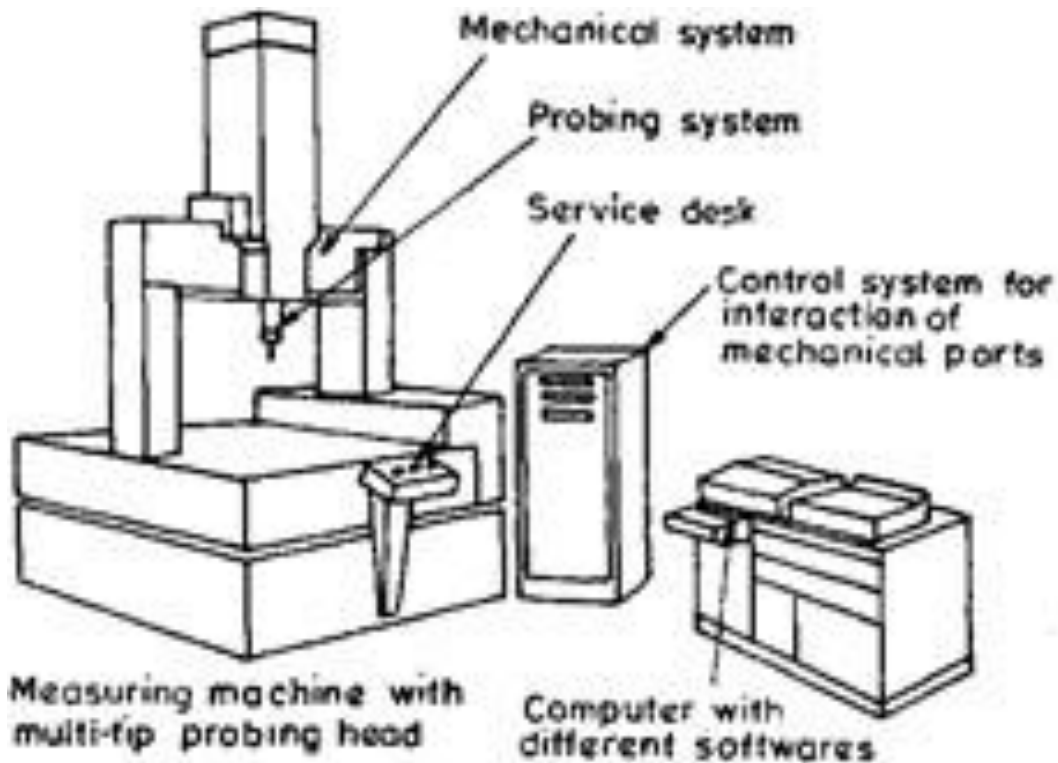
- Measurement of diameter, centre distances, lengths, geometrical and form errors in prismatic components etc.
- On-line statistics for statistical information in a batch.
- Parameter programming to minimize CNC programming time of similar parts.
- Measurement of plane and spatial curves.
- Data communications.

## CAD/CAM/CIM

- Digital input and output commands for process integration.
- Programs for the measurement of spur, helical, bevel and hypoid gears.
- Interface to CAD software.

### TYPES OF CMM

- (i) Column type
- (ii) Bridge type
- (iii) Cantilever type
- (iv) Gantry type



### ADVANTGES OF CNC OPERATION OF CMM

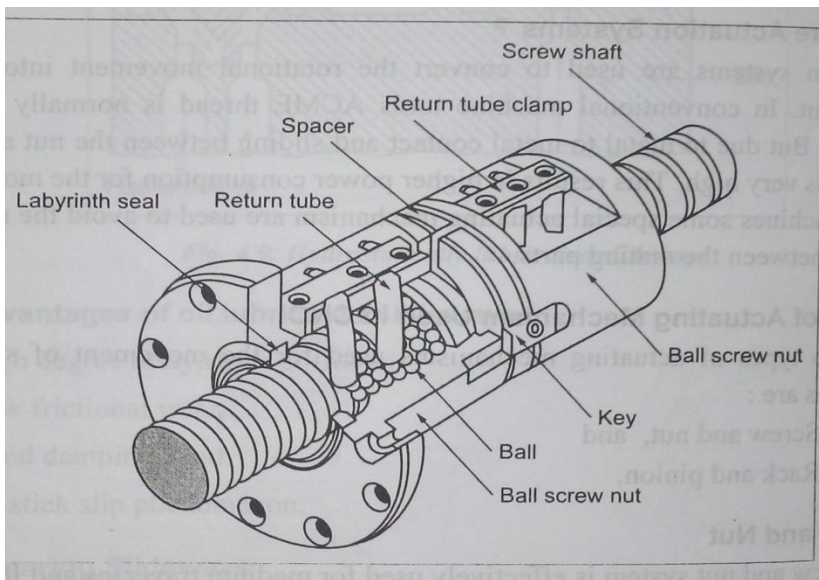
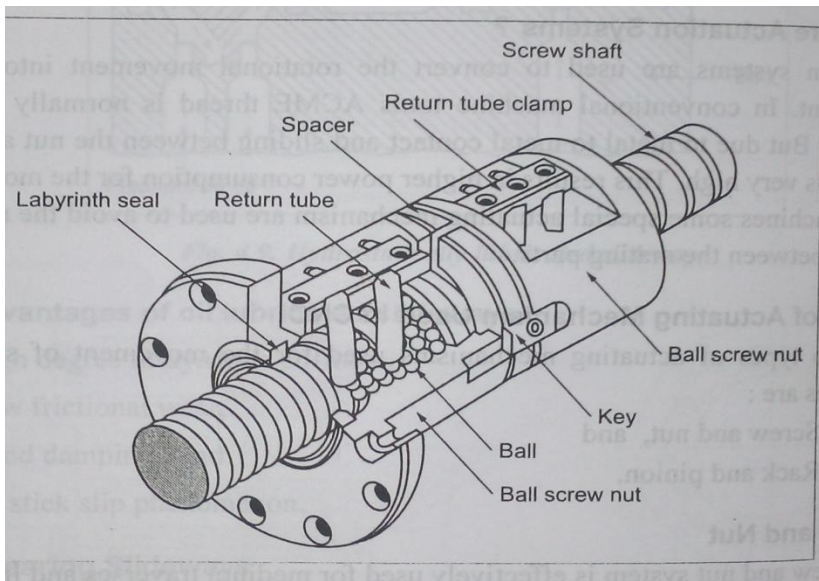
- CNC operation increases cost effectiveness through the following advantages:
  - i. Shorter measuring times



- ii. Higher throughput rates
- iii. Better repeatability
- iv. Economical even for small batches
- v. Simple operation
- vi. Unmanned second and third shift inspection of parts if parts are loaded automatically.

**RECIRCULATING BALL SCREW**

- Actuation system are used to convert the rotational movement into translational movement.in conventional machine tools ACME thread is normal used for this purpose. Its connect with CNC table.



## GUIDE WAYS

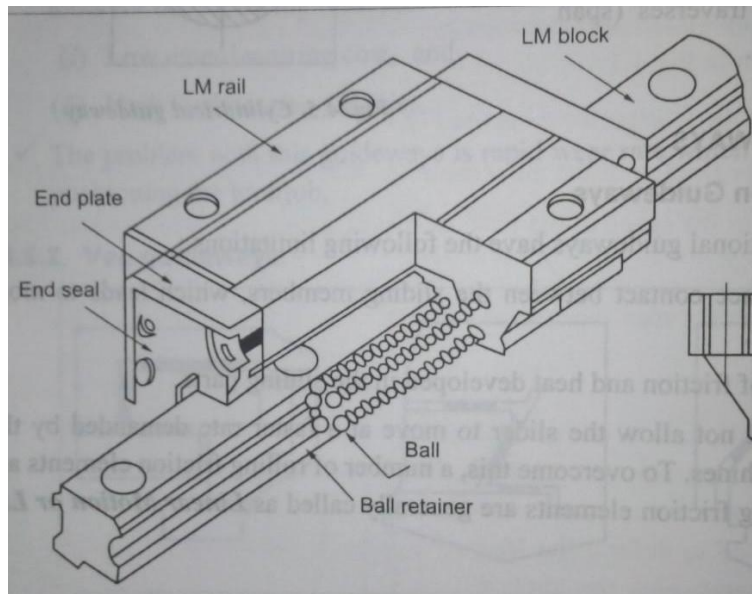
Function of guide ways or slide ways

- To control the line of action the carriage/table on which tool /work piece is held.
- To absorb static and dynamic force

Types

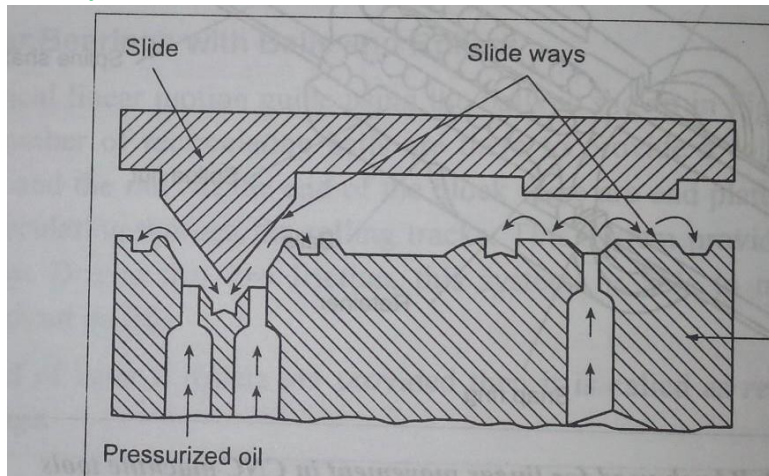
1. Friction guide ways (Flat,v,dovetail guide ways)
2. Antifriction guide ways (LM guide ways)
3. Hydrostatic guide ways (Oil lubricated guide ways).

## LINEAR MOTION GUIDE WAYS





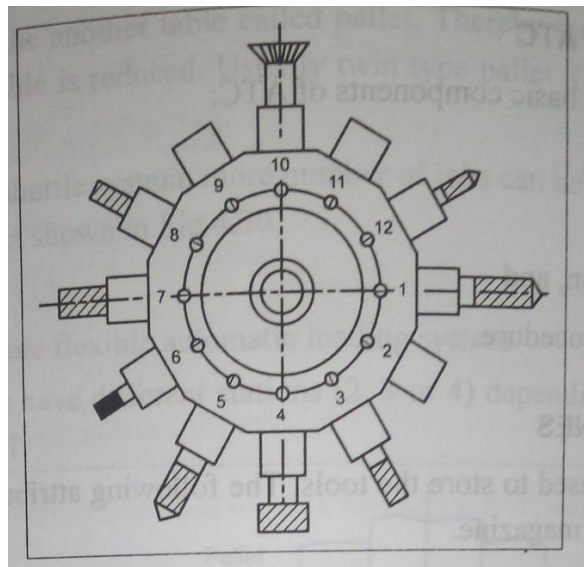
### Oil lubricated guide ways



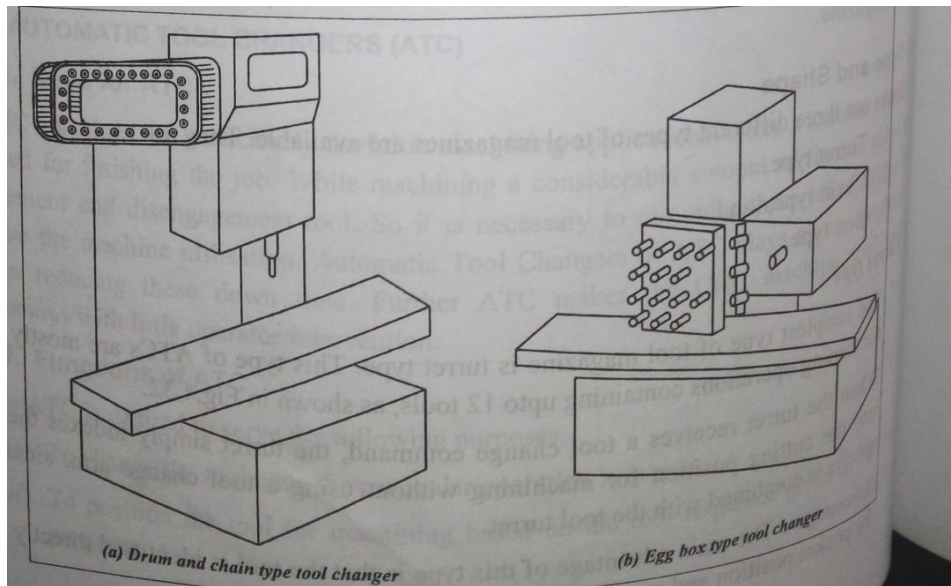
### TOOL MAGAZINES

- Tool magazines are used to store the tools. The following attributes be considered before selecting the tools
- Storage capacity ( 12 to 200 tools but commonly used 30 to 60).
- Type and shape (Turret,chain,box type)
- Tool change procedure

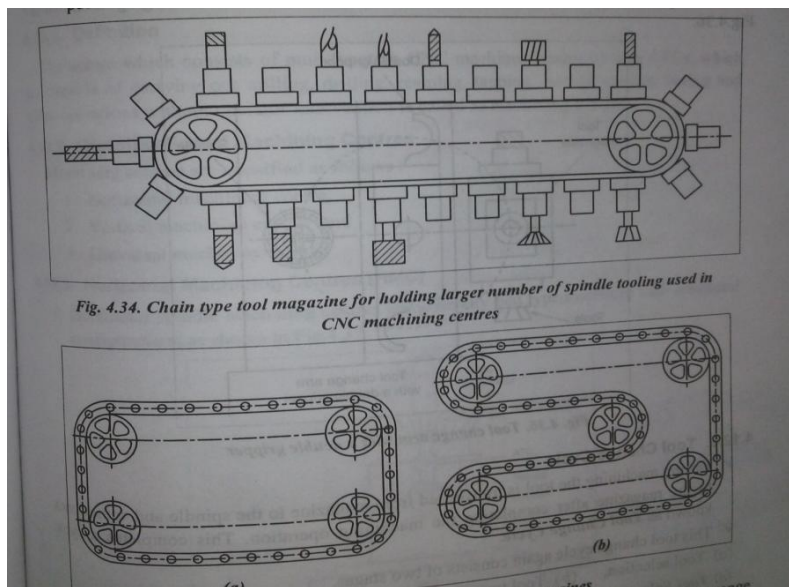
### TYPES OF TOOL MAGAZINES TURRET TYPE



**DRUM TYPE**



**CHAIN TYPE**



**ATC (AUTOMATIC TOOL CHANGERS)**

**FUNCTION**

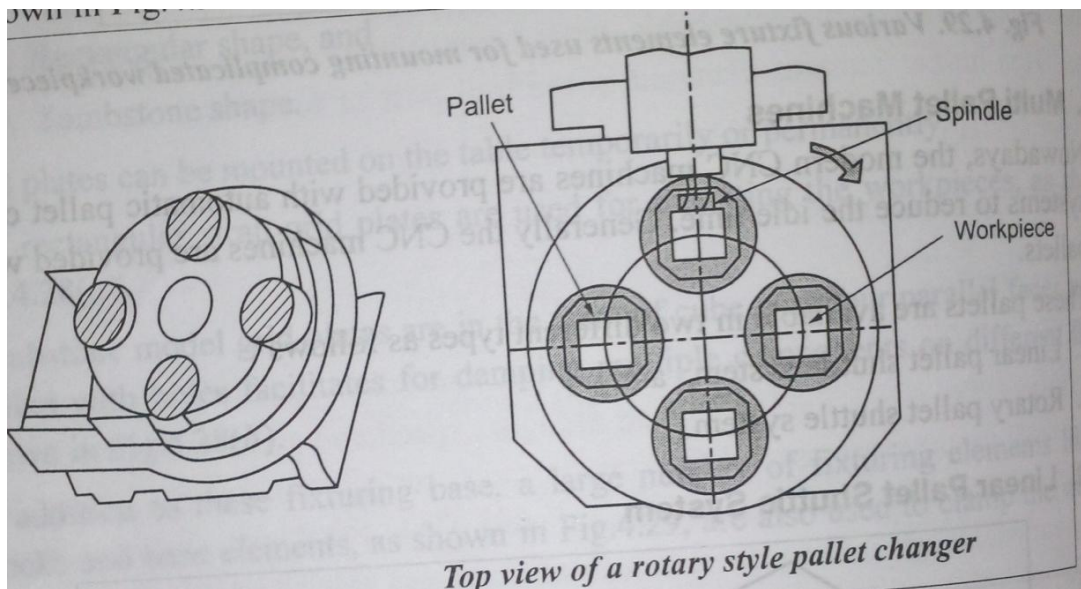
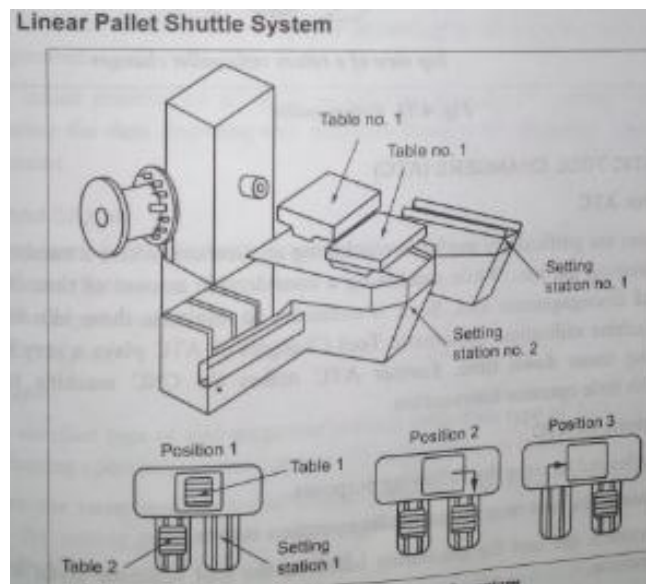
- To change the tool once the particular operation is over.

## CAD/CAM/CIM

- To position the tool for machining based on the tool sequence given in the part programme.

### APC ( AUTOMATIC PALLET CHANGE OVER)

- The modern CNC machine are provided with automatic pallet change over system to reduce the idle time.
- Types
- Linear pallet shuttle system
- Rotary pallet shuttle system



### CHIP CONVEYORS

- The unwanted materials remove from the work piece is called a chip.

## CAD/CAM/CIM

- The chip conveyor helped to transfer the chip from cnc machine to scrap storage area.
- The chip conveyor run by electric motor

### Micro processor based CNC system

- A microprocessor is an integrated circuit chip containing the digital logic elements needed to perform arithmetic calculations, execute instructions stored in memory and carry out other data processing tasks. The digital logical elements and their interconnections in the circuit form a built-in set of instructions that determines the functions of the microprocessor. A very common function is to serve as the central processing unit microcomputer, by definition. A microcomputer is simply a small digital computer whose CPU is a microprocessor and which performs the BASIC functions of a computer. These basic functions consist of data manipulation and computation carried out according to software stored in memory to accomplish user applications, the most familiar and widely used example of a microcomputer is the personal Computer (PC), usually programmed with software for business and personal applications.

### UNIT 2 Objective type questions

1) On turning lathes the machine zero point is generally at the\_\_\_\_\_.

- a) Head stock of lathe spindle nose face      c) Tool point mounted on tool post  
b) Dead center of tail stock                      d) none of the above

Ans:- Dead center of tail stock

2) M30 stands for:

- a. End of program                                      b. End of block  
c. End of tape and tape rewind                      d. Coolant on/off

Ans:- End of tape and tape rewind

3) Dwell is defined by

- a. G04    b. G03  
c. G02    d. G01

Ans:- G04

4) „Moiré fringe“ is associated with:

CAD/CAM/CIM

- a. Open loop control system
- b. Rotary encoder
- c. Closed loop control system
- d. linear scale

Ans:- linear scale

5) NC contouring is an example of\_\_\_\_\_.

- a. Continuous path positioning
- b. Point-to-point positioning
- c. Absolute positioning
- d. Incremental, positioning

Ans:- Continuous path positioning

6) In control system the hardware device that converts a controller command signal into a change in a physical parameter:

- a) Actuator
- b) ATC
- c) Encoders
- d) Recirculating ball screw

Ans:- Actuators

7) In CNC machine tool the position feedback package is connected between

- a) Control unit and programmer
- b) Control unit and machine tool
- c) Programmer and machine tool
- d) None of the above

Ans:- Control unit and machine tool

8) M06 stands for:

- a) coolant off
- b) Spindle stop
- c) Clamp
- d) Tool change

Ans: Tool change

9) In CNC machine tool the part program entered into the computer memory

- a) Can be used only once
- b) Can be used again but it has to be modified every time
- c) Can be used again and again
- d) cannot say

CAD/CAM/CIM

Ans: Can be used again and again

10) G-codes stand for:

- a) Miscellaneous function
- b) Preparatory function
- c) Sequence number
- d) none of the above

Ans: Preparatory function

11) IN CNC machine tools the tools are stored in:

- a) Magazine
- b) Tool changer
- c) Pallet
- d) none of the above

Ans: Magazine

12) The device, fed to the control unit of NC machine tool which sends the position command signals to sideway transmission elements of the machine, is called as

- a) Controller
- b) Feedback unit
- c) tape
- d) none of the above

Ans: feedback unit

13) Which machine tool reduces the number of set-ups in machining operation, time spent in setting machine tools and transportation between sections of machines?

- a) Computer Numerical Control machine tool
- b) Adaptive Control Systems
- c) Direct Numerical Control machine tool
- d) Machining center

Ans: Machining center

14) The machine tool, in which calculation and setting of the operating conditions like depth of cut, feed, and speed are done during the machining by the control system itself, is called

- a) Computer Numerical Control System
- b) Machining Centre System
- c) Direct Numerical Control System
- d) Adaptive Control System

Ans: Adaptive Control System

15) Several machine tools can be controlled by a central computer in

- a) NC
- b) DNC
- c) CNC
- d) CCNC

Ans: DNC

<b>UNIT-III</b>	<b>CNC CONTROL SYSTEM AND PART PROGRAMMING</b>	<b>9</b>
Pneumatic and hydraulic control system, Open loop and closed loop control system, microprocessor based CNC system, description of hardware and software interpolation system, feedback devices: encoders – linear and rotary transducers – in-process probing. NC dimensioning –reference points – machine zero, work zero, tool zero and tool offsets, compensation. Coordinate system – types of motion control: point-to-point, paraxial and contouring – Types of NC part programming – G and M codes - turning and milling part programming examples - interpolation – macro – subroutines – canned cycles – mirror images.		

## UNIT-III CNC CONTROL SYSTEM AND PART PROGRAMMING

### Configuration of CNC machine

7

#### CONFIGURATION OF THE CNC SYSTEM

Fig.1 shows a schematic diagram of the working principle of a NC axis of a CNC machine and the interface of a CNC control.

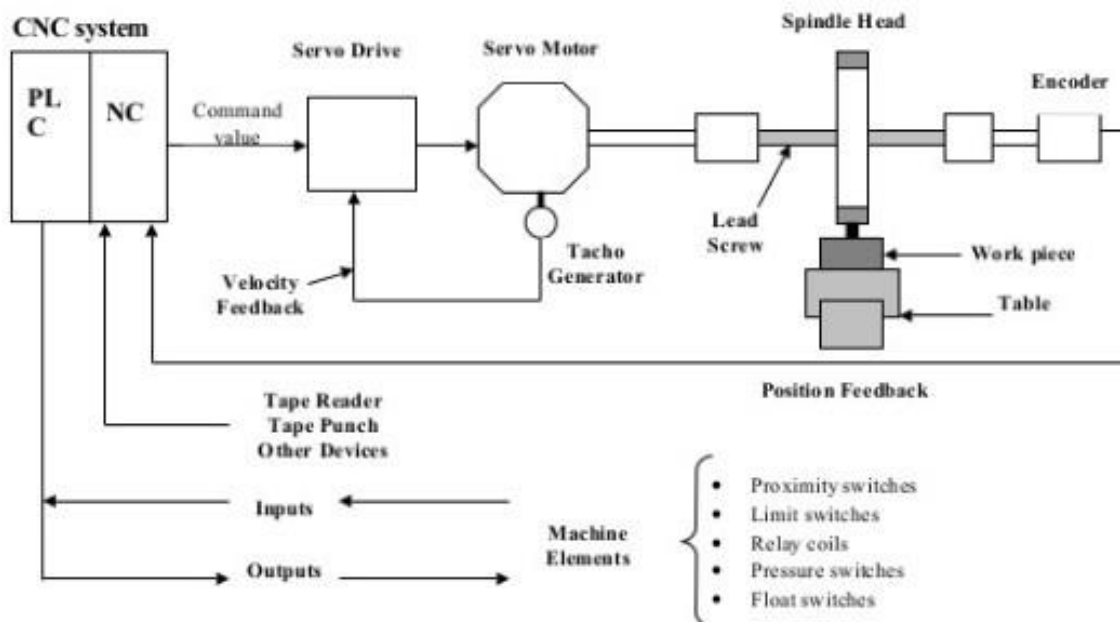


Fig.1 Schematic diagram of a CNC machine tool



# Properties of CNC machines

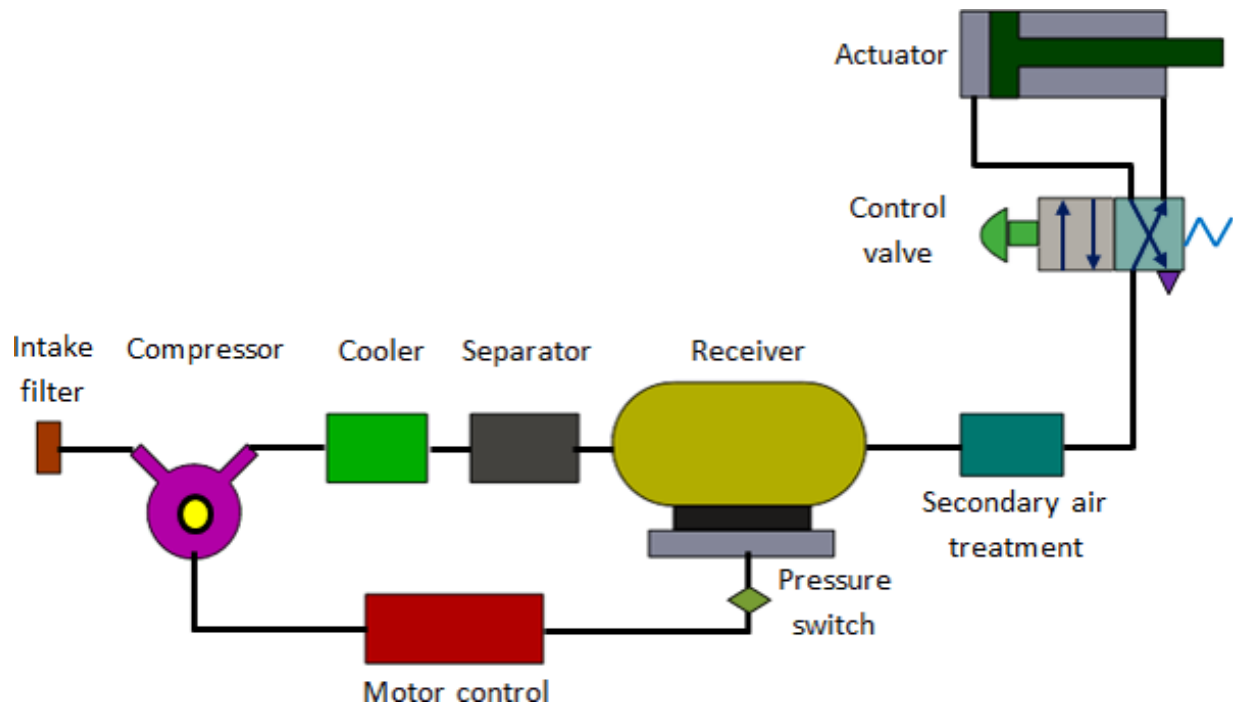
Clip size

- **Based on Motion Type: Motion control - the heart of CNC**  
Point-to-Point or Continuous path
  
- **Based on Control Loops:**  
Open loop or Closed loop
  
- **Based on Power Supply:**  
Electric or Hydraulic or Pneumatic
  
- **Based on Positioning System**  
Incremental or Absolute

## Pneumatic systems

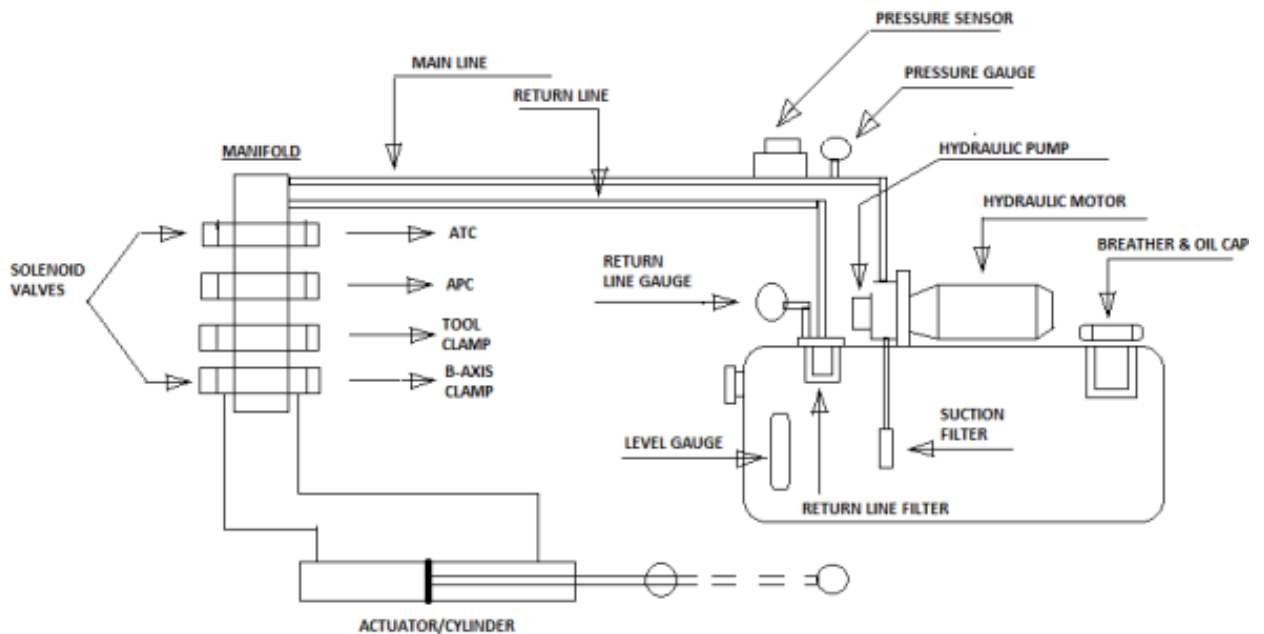
- Pneumatic technology deals with the study of behavior and applications of compressed air in our daily life in general and manufacturing automation in particular. Pneumatic systems use air as the medium which is abundantly available and can be exhausted into the atmosphere after completion of the assigned task.

Components of a pneumatic system (case study refer ppt)



Hydraulic System In CNC Machine

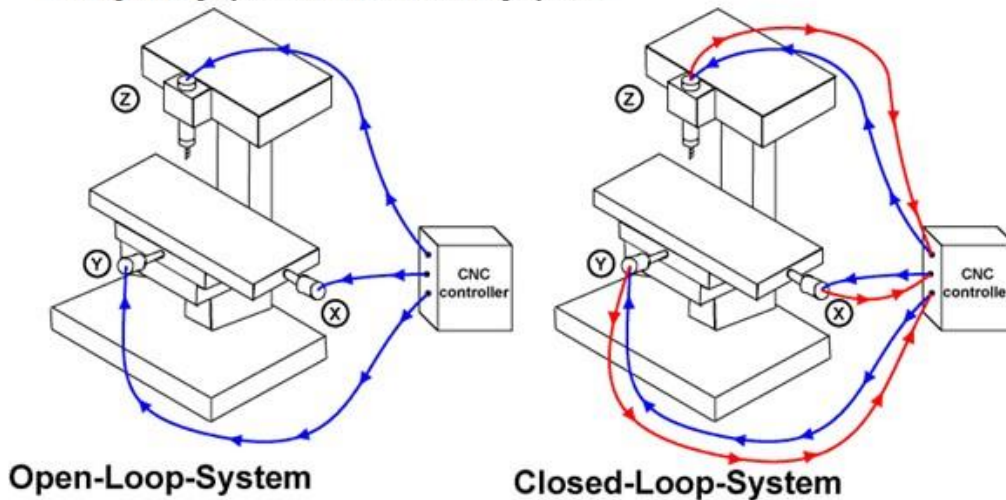
- Tool clamp/declamp operation :
- Pallet clamp/declamp operation :
- Hydro-motor for arm rotation or turret rotation
- Hydraulic hammer for hot and cold swagging
- Rotational axis clamp/declamp :



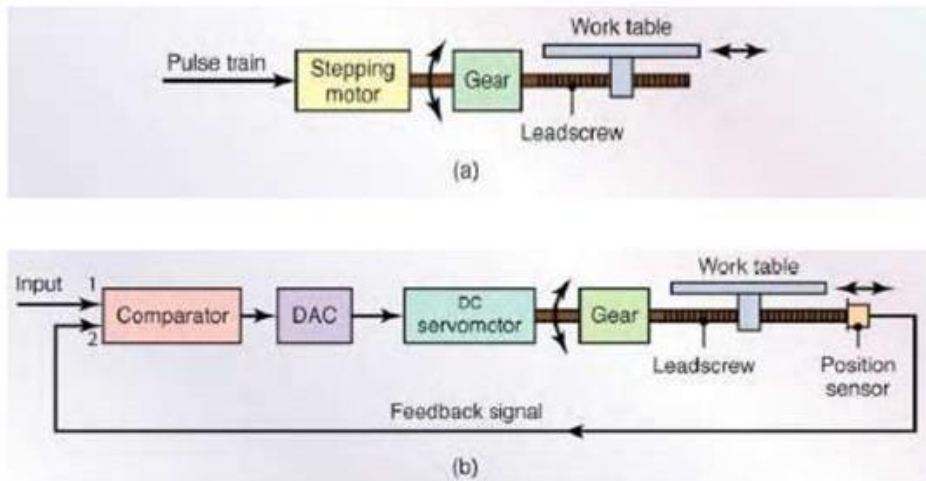
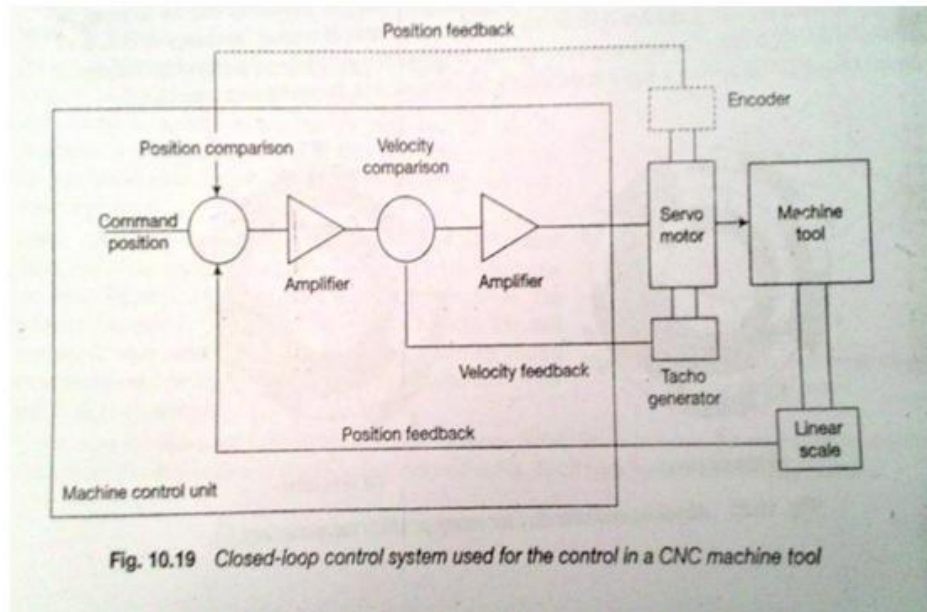
- Hydraulic system is nothing but a system operated by hydraulic oil. When there is a need of much pressure in low volumetric area, Hydraulic system gives us the solution.
- CNC machine is such type of machine where several jobs are executed in compact area and in less time. In such scenario, hydraulic systems play a big role to execute several functions.
- Hydraulic Pressure in CNC machine is developed by hydraulic power pack which is a combination of several hydraulic components.
- Hydraulic circuit is a close circuit. A hydraulic pump is incorporated to raise the pressure up to desired system pressure and that system pressure is distributed to various work places through solenoid valves and regulated through hydraulic pressure regulators.

### Open loop and closed loop control system

- CNC systems require motor drives to control both the position and the velocity of the machine axes. Each axis must be driven separately and follow the command signal generated by the NC control. There are two ways to activate the servo drives: the open-loop system and the closed-loop system.

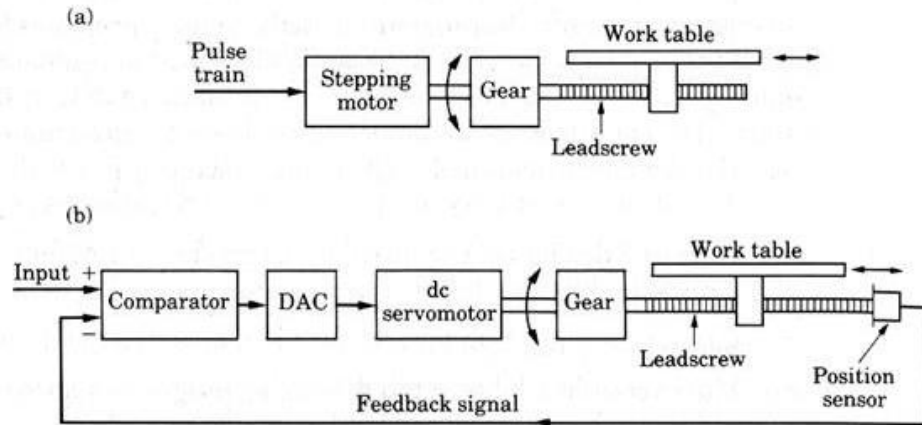


# Closed loop control system



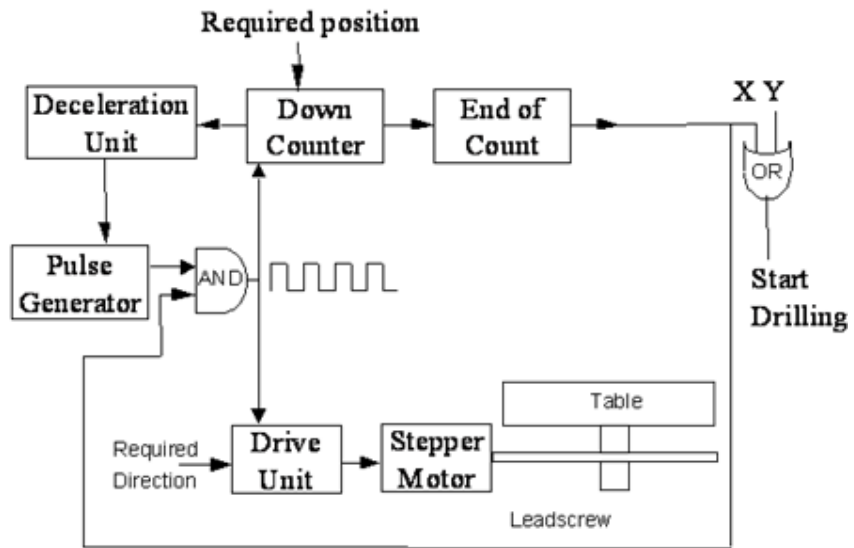
Schematic illustration of the components of (a) an open-loop and (b) a closed-loop control system for a CNC machine.

**Open Loop vs. Closed Loop controls**

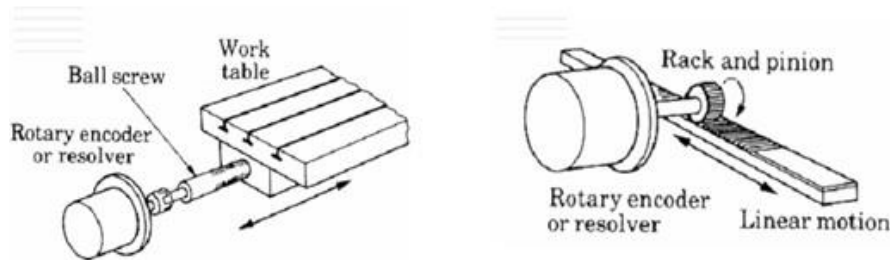
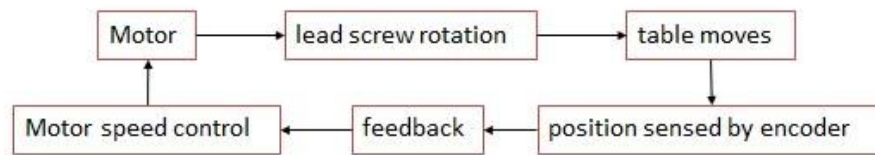


**Open loop control of a Point-to-Point NC drilling machine**

NOTE: this machine uses stepper motor control



### Components of Servo-motor controlled CNC



Two types of encoder configurations

### Controller

- A controller is an electronic regulating mechanism used on [CNC](#) machinery. For example the controller reads a CNC program and sends signals to the [axis](#) motors on the machine.

### Open loop control system:

- Programmed instructions are fed into the [controller](#) through an input device. These instructions are then converted to electrical pulses (signals) by the controller and sent to the servo amplifier to energize the servo motors. The cumulative number of electrical pulses determines the distance each servo drive will move, and the pulse frequency determines the velocity.
- The primary drawback of the open-loop system is that there is no feedback system to check whether the program position and velocity has been achieved. If the system performance is affected by load, temperature, humidity, or lubrication then the actual output could deviate from the desired output.
- For these reasons, the open-loop system is generally used in point-to-point systems where the accuracy requirements are not critical. Very few, if any, continuous-path systems utilize open-loop control.

**The closed-loop** system has a feedback subsystem to monitor the actual output and correct any discrepancy from the [programmed](#) input. The feedback system could be either analog or digital. The analog systems measure the variation of physical variables such as position and velocity in terms of voltage levels. Digital systems monitor output variations by means of electrical pulses

- Closed-loop systems are very powerful and accurate because they are capable of monitoring operating conditions through feedback subsystems and automatically compensating for any variations in real-time.
- Most modern closed-loop CNC systems are able to provide very close resolution of 0.0001 of an inch.

**Feedback** can be accomplished in one of two ways

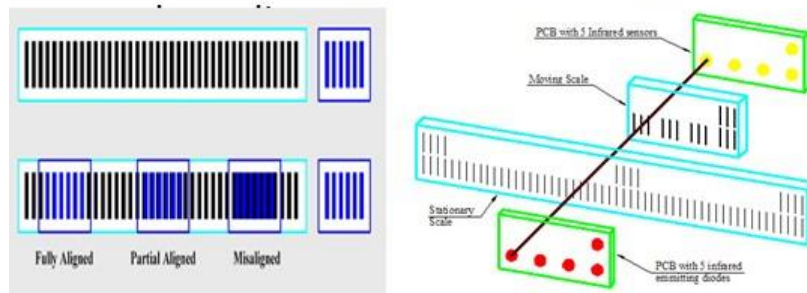
- **Linear Scales**
- **Encoders**

**Note- SERVOMOTOR-it is an automatic device that uses error sensing negative feedback to correct the performance of a mechanism.**

### Linear scale-

#### Linear scale-

- It measures the absolute/exact position of the slide directly.
- It is a graduated scale made of either glass or stainless steel along with a measuring surface and



### Encoder-

- An encoder is a sensor of mechanical motion that generates digital signals in response to motion. As an electro-mechanical device, an encoder is able to provide motion control system users with information concerning position, velocity and direction.
- They convert rotary movement into digital signals.

#### Types of encoders

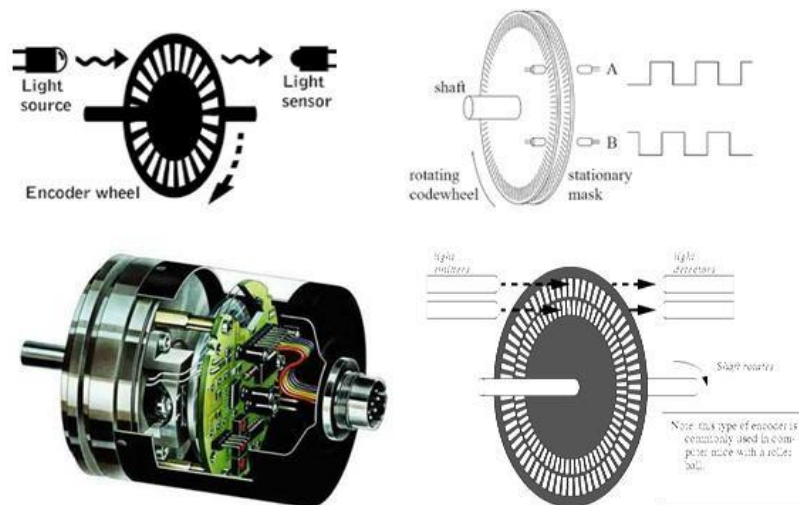
- There are two different types of encoders: linear and rotary.
- A linear encoder responds to motion along a path, while a rotary encoder responds to rotational motion.



- An encoder is generally categorized by the means of its output. An incremental encoder generates a train of pulses which can be used to determine position and speed. An absolute encoder generates unique bit configurations to track positions directly.

**Difference between incremental and absolute encoder-**

- Incremental rotary encoder outputs the pulse corresponding to the rotation angle only while rotating, and is the counting measurement method that adds up the pulse from the measurement beginning point.
- Absolute rotary encoder outputs the signal of position corresponding to the rotation angle by code. The Absolute position from the starting point is measured by the output code data. The position is memorized though the power supply is cut off.



**CNC interpolation**

- **Interpolation** is a method of constructing new data points within the range of a discrete set of known data points.
- Estimation of an unknown quantity between two known quantities .It is a mathematical process to determine new points on curved surface within two end points.
- It produces a series of intermediate data points between given coordinate positions and computes the axial velocity of an individual axis along the contour path.

**Types of interpolation-(REFER G CODE)**

**To coordinate the axis movements in CNC control these types of interpolation are used**

- Linear interpolation: This moves tool from start point to the target point along a straight line. It can be implemented in a 2-D plane or 3-D space. the programming command should indicate X, Y, Z coordinates of target point, and feed rate.



- Circular interpolation: It is programmed to cut circular arcs in three principal planes; namely XY, YZ, ZX. Direction, target position, arc radius, cutting plane, and feed rate must be specified in the program.
- Helical interpolation: Helical interpolation combines the two-axis circular interpolation with a linear interpolation in third axis. i.e. machining of helical pockets and threads

### **Modern approaches to interpolation-**

#### **1.hardware interpolation-**

- It consists of a pair of DDA integrators.
- It is capable of doing linear and circular operations according to instruction from the punched tapes.
- The main feature of hardware interpolation is that it controls simultaneously two axes which can be X and Y, X and Z or Y and Z.
- Hardware circuits generate the points that keep the tool path within tolerance.
- It is used for fine interpolation.

#### **2.Software interpolation-**

- This is the computer based approach of hardware interpolation.
- Basically it is a computer program which simulates a single cycle of hardware interpolator and the feed rate control.
- The computer analysis program divides the tool path into segments.
- Used for coarse(rough) interpolation.
- It is microprocessor based interpolation system, samples about 100 times/second are to be taken in this system.

### **Features of CNC**

- For a CNC machine control unit (MCU) decides cutting speed, feed, depth of cut, tool selection, coolant on off and tool paths.
- The MCU issues commands in form of numeric data to motors that position slides and tool accordingly.
- The tool or material moves.
- Tools can operate in 1-5 axes.[multi axis machining]
- Larger machines have a machine control unit (MCU) which manages operations
- Movement is controlled by a motors .

**Feedback is provided by sensors.**

- During every machining operation, the CNC machine uses a series of numerical instructions sent by the part program to control movements along the axes. These programs require a starting point that accurately lines up the cutting tool and the workpiece.

Each CNC machine has a built-in location that is called machine zero. This point typically is located at the farthest positive direction along the X-, Y-, and Z-axes, and it cannot be changed by anyone after it leaves the original manufacturer. A cutting tool or a worktable can be moved to the machine zero position for the loading and unloading of parts.

In addition to machine zero, each part program sets a starting location called program zero. Unlike machine zero, the programmer selects the program zero for each workpiece. This location acts as the origin from which all the other dimensions are calculated during the program and it is usually located on the edge of a workpiece. The CNC machine then adjusts its calculations to accurately align the cutting tool with the workpiece.

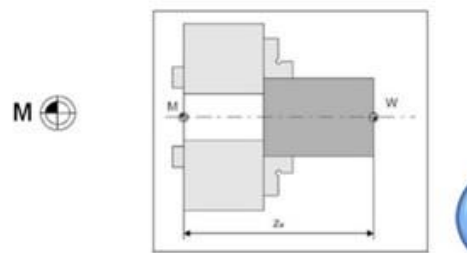
**Machine Zero Point (M):**

The origin of the coordinate system.

It is defined by the manufacturer and cannot be changed. In general, the machine zero point M is located in the center of the work spindle nose for CNC lathes.

**Machine Zero Point (M):**

Fig. 1.6 and 1.7 show (M) machine zero point for lathe machine and its symbol.



## Workpiece Zero Point (W):

The workpiece zero point (W) is the origin of the work part-based coordinate system. Its location is specified by the programmer.

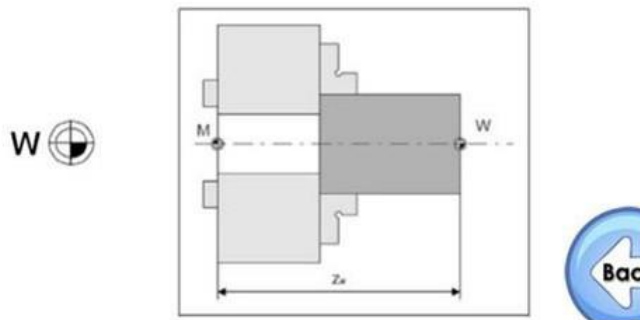
## Workpiece Zero Point (W):

The ideal location of the work part zero point allows the dimensions to be directly taken from the drawing.

In case of turning the workpiece zero point is generally in the center of the left or right side of the completed part.

## Workpiece Zero Point (W):

Fig. 1.6 and 1.7 show (W) workpiece zero point and its symbol.



**1.3.3 Zero And Reference Points**  
**CNC Machine Tools**

a) *Types Of Zero And Reference Points*

Table 1.1 : *Types of zero and references points*

	<b>M</b>	machine zero point
	<b>W</b>	work part zero point
	<b>R</b>	reference point
	<b>E</b>	tool reference point
	<b>B</b>	tool setup point
	<b>A</b>	tool shank point
	<b>N</b>	tool change point

### Machine Tool Zero Point Setting

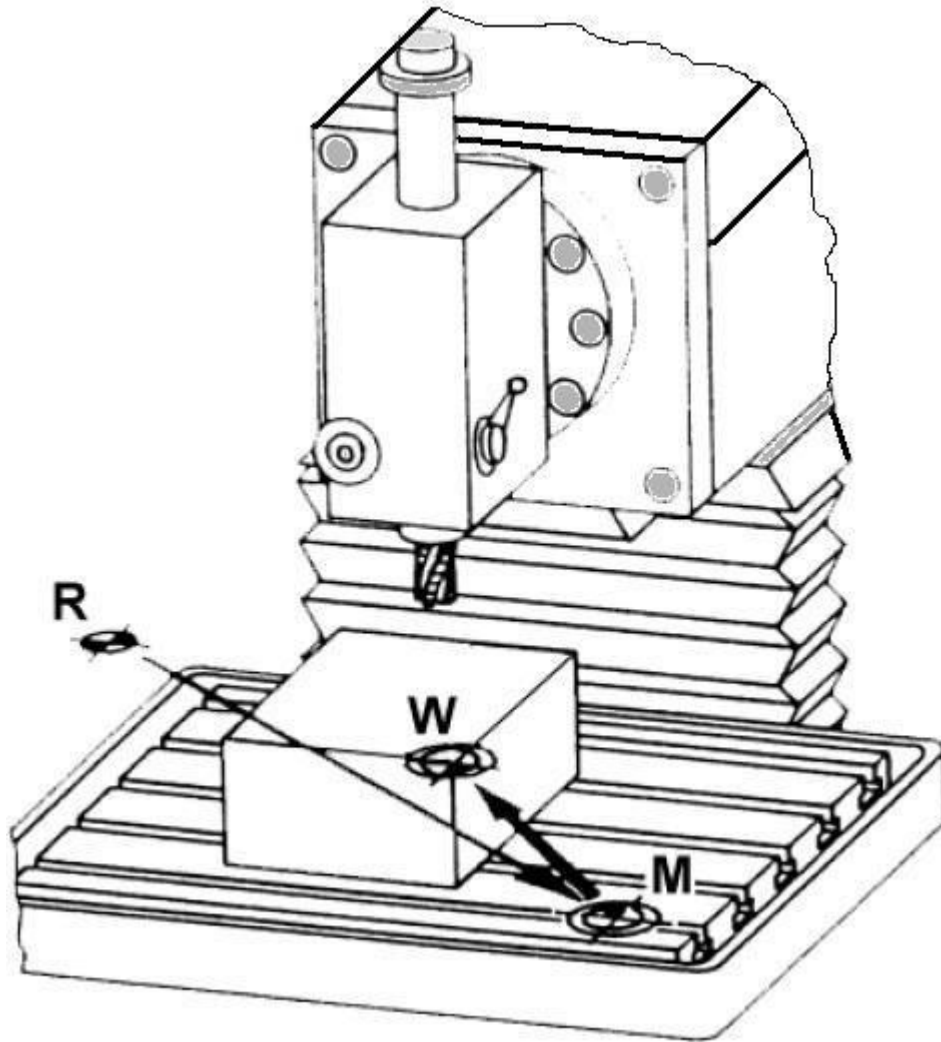
The machine zero point can be set by two methods by the operator, manually by a programmed absolute zero shift, or by work coordinates, to suit the holding fixture or the part to be machined.

### Manual Setting

The operator can use the MCU controls to locate the spindle over the desired part zero and then set the X and Y coordinate registers on the console to zero.

### Absolute Zero Shift

The absolute zero shift can change the position of the coordinate system by a command in the CNC program. The programmer first sends the machine spindle to home zero position by a command in the program. Then another command tells the MCU how far from the home zero location, the coordinate system origin is to be positioned.



$R$  = Reference point (maximum travel of machine)

$W$  = Part zero point workpiece coordinate system

$M$  = Machine zero point ( $X_0, Y_0, Z_0$ ) of machine coordinate system



## CLASSIFICATION OF CNC MACHINE TOOLS

### (1) Based on the motion type 'Point-to-point & Contouring systems

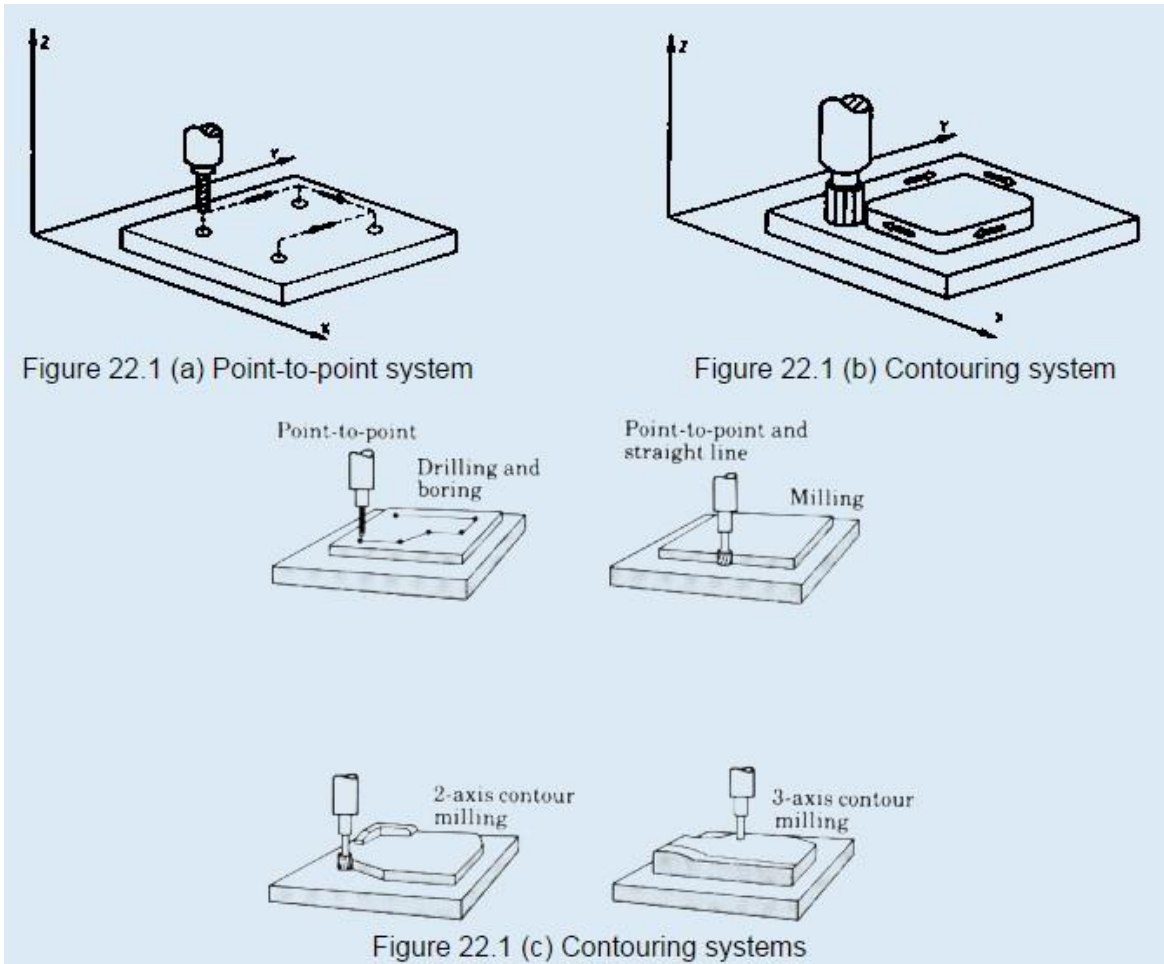
There are two main types of machine tools and the control systems required for use with them differ because of the basic differences in the functions of the machines to be controlled. They are known as point-to-point and contouring controls.

### Point-to-point systems

- Some machine tools for example drilling, boring and tapping machines etc, require the cutter and the work piece to be placed at a certain fixed relative positions at which they must remain while the cutter does its work.
- These machines are known as point-to-point machines as shown in figure 22.1 (a) and the control equipment for use with them are known as point-to-point control equipment.
- Feed rates need not to be programmed. In these machine tools, each axis is driven separately. In a point-to-point control system, the dimensional information that must be given to the machine tool will be a series of required positions of the two slides.
- Servo systems can be used to move the slides and no attempt is made to move the slide until the cutter has been retracted back.

### Contouring systems (Continuous path systems)

- Other type of machine tools involves motion of work piece with respect to the cutter while cutting operation is taking place. These machine tools include milling, routing machines etc. and are known as contouring machines as shown in figure 22.1 (b) and the controls required for their control are known as contouring control. Contouring machines can also be used as point-to-point machines, but it will be uneconomical to use them unless the work piece also requires having a contouring operation to be performed on it.
- These machines require simultaneous control of axes. In contouring machines, relative positions of the work piece and the tool should be continuously controlled. The control system must be able to accept information regarding velocities and positions of the machines slides. Feed rates should be programmed.



## 3.3 CNC PROGRAMMING

**The part program** is a sequence of instructions, which describe the work, which has to be done on a part, in the form required by a computer under the control of a numerical control computer program.

- It is the task of preparing a program sheet from a drawing sheet. All data is fed into the numerical control system using a standardized format.
- Programming is where all the machining data are compiled and where the data are translated into a language which can be understood by the control system of the machine tool. The machining data is as follows :
  - (a) Machining sequence classification of process, tool start up point, cutting depth, tool path, etc.
  - (b) Cutting conditions, spindle speed, feed rate, coolant, etc.



(c) Selection of cutting tools.

➤ While preparing a part program, need to perform the following steps :

(a) Determine the startup procedure, which includes the extraction of dimensional data from part drawings and data regarding surface quality requirements on the machined component.

(b) Select the tool and determine the tool offset.

(c) Set up the zero position for the work piece.

(d) Select the speed and rotation of the spindle.

(e) Set up the tool motions according to the profile required.

(f) Return the cutting tool to the reference point after completion of work.

(g) End the program by stopping the spindle and coolant

❖ The part programming contains the list of coordinate values along the *X*, *Y* and *Z* directions of the entire tool path to finish the component. The program should also contain information, such as feed and speed.

❖ Each of the necessary instructions for a particular operation given in the part program is known as an NC word. A group of such NC words constitutes a complete NC instruction, known as block.

❖ The commonly used words are *N*, *G*, *F*, *S*, *T*, and *M*. The same is explained later on through examples.

Hence the methods of part programming can be of two types depending upon the two techniques as below :

(a) Manual part programming, and

(b) Computer aided part programming.

### MANUAL PART PROGRAMMING

- The programmer first prepares the program manuscript in a standard format. Manuscripts are typed with a device known as flexo writer, which is also used to type the program instructions.
- After the program is typed, the punched tape is prepared on the flexo writer. Complex shaped components require tedious calculations.
- This type of programming is carried out for simple machining parts produced on point-to-point machine tool.

To be able to create a part program manually, need the following information:

(a) Knowledge about various manufacturing processes and machines.



- (b) Sequence of operations to be performed for a given component.
- (c) Knowledge of the selection of cutting parameters.
- (d) Editing the part program according to the design changes.
- (e) Knowledge about the codes and functions used in part programs.

### Computer Aided Part Programming

- If the complex-shaped component requires calculations to produce the component are done by the programming software contained in the computer.
- The programmer communicates with this system through the system language, which is based on words.
- There are various programming languages developed in the recent past, such as APT (Automatically Programmed Tools), ADAPT, AUTOSPOT, COMPAT-II, 2CL, ROMANCE, SPLIT is used for writing a computer programme, which has English like statements. A translator known as compiler program is used to translate it in a form acceptable to MCU.

### Standard G and M Codes

- The most common codes used when programming NC machines tools are G-codes (preparatory functions), and M codes (miscellaneous functions). Other codes such as *F*, *S*, *D*, and *T* are used for machine functions such as feed, speed, cutter diameter offset, tool number, etc.
- G-codes are sometimes called cycle codes because they refer to some action occurring on the *X*, *Y*, and/or *Z*-axis of a machine tool. The G-codes are grouped into categories such as Group 01, containing codes G00, G01, G02, G03, which cause some movement of the machine table or head. Group 03 includes either absolute or incremental programming.

A G00 code rapidly positions the cutting tool while it is above the workpiece from one point to another point on a job. During the rapid traverse movement, either the *X* or *Y*-axis can be moved individually or both axes can be moved at the same time. The rate of rapid travel varies from machine to machine

### G-Codes (Preparatory Functions)

Code Function

G00 Rapid positioning

G01 Linear interpolation

G02 Circular interpolation clockwise (CW)

G03 Circular interpolation counterclockwise (CCW)

G20 Inch input (in.)

## CAD/CAM/CIM

G21 Metric input (mm)

G24 Radius programming

G28 Return to reference point

G29 Return from reference point

G32 Thread cutting

G40 Cutter compensation cancel

G41 Cutter compensation left

G42 Cutter compensation right

G43 Tool length compensation positive (+) direction

G44 Tool length compensation minus (-) direction

G49 Tool length compensation cancels

G 53 Zero offset or M/c reference

G54 Settable zero offset

G84 canned turn cycle

G90 Absolute programming

G91 Incremental programming

**Note :** On some machines and controls, some may be differ.

### M-Codes (Miscellaneous Functions)

- M or miscellaneous codes are used to either turn ON or OFF different functions, which control certain machine tool operations.
- M-codes are not grouped into categories, although several codes may control the same type of operations such as M03, M04, and M05, which control the machine tool spindle. Some of important codes are given as under with their functions:
- Code Function
- M00 Program stop
- M02 End of program
- M03 Spindle start (forward CW)
- M04 Spindle start (reverse CCW)
- M05 Spindle stop
- M06 Tool change

## CAD/CAM/CIM

- M08 Coolant on
- M09 Coolant off
- M10 Chuck - clamping
- M11 Chuck - unclamping
- M12 Tailstock spindle out
- M13 Tailstock spindle in
- M17 Tool post rotation normal
- M18 Tool post rotation reverse
- M30 End of tape and rewind or main program end
- M98 Transfer to subprogram
- M99 End of subprogram

**Note :** On some machines and controls, some may be differ.

### **CNC terminology**

#### **BLU: basic length unit →**

smallest programmable move of each axis.

#### **Controller: (Machine Control Unit, MCU) →**

Electronic and computerized interface between operator and m/c

Controller components:

1. Data Processing Unit (DPU)
2. Control-Loops Unit (CLU)

### **Types of CNC machines**

*Based on Motion Type:*

Point-to-Point    or    Continuous path

*Based on Control Loops:*

Open loop    or    Closed loop

*Based on Power Supply:*

Electric    or    Hydraulic    or    Pneumatic

*Based on Positioning System*

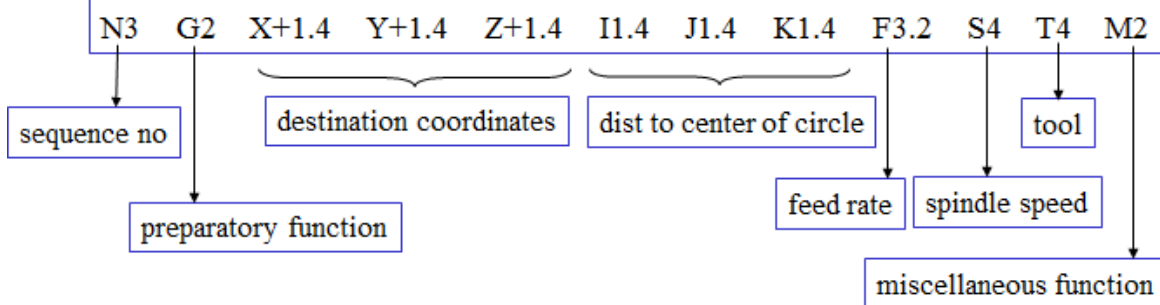
Incremental    or    Absolute

The RS274-D is a **word address format**

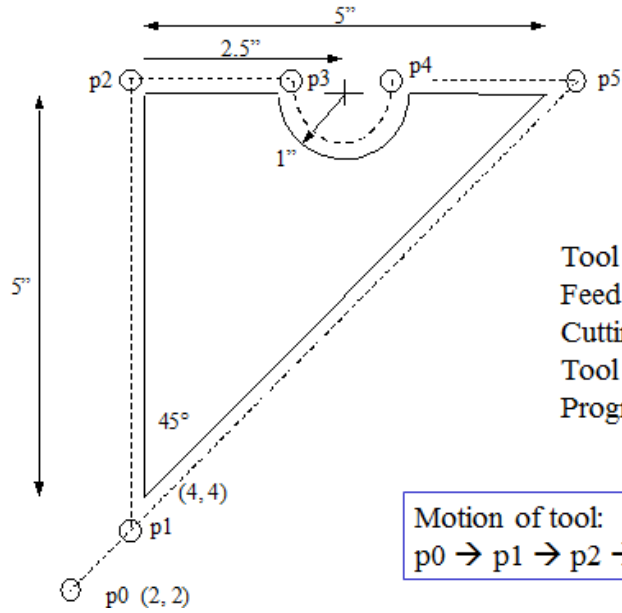
Each line of program == 1 **block**

Each block is composed of several instructions, or (**words**)

Sequence and format of words:

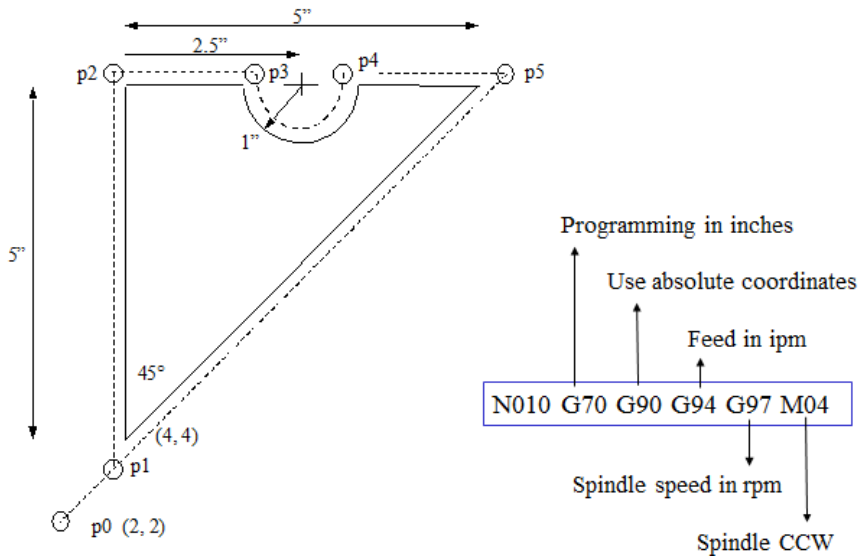


## Manual Part Programming Example

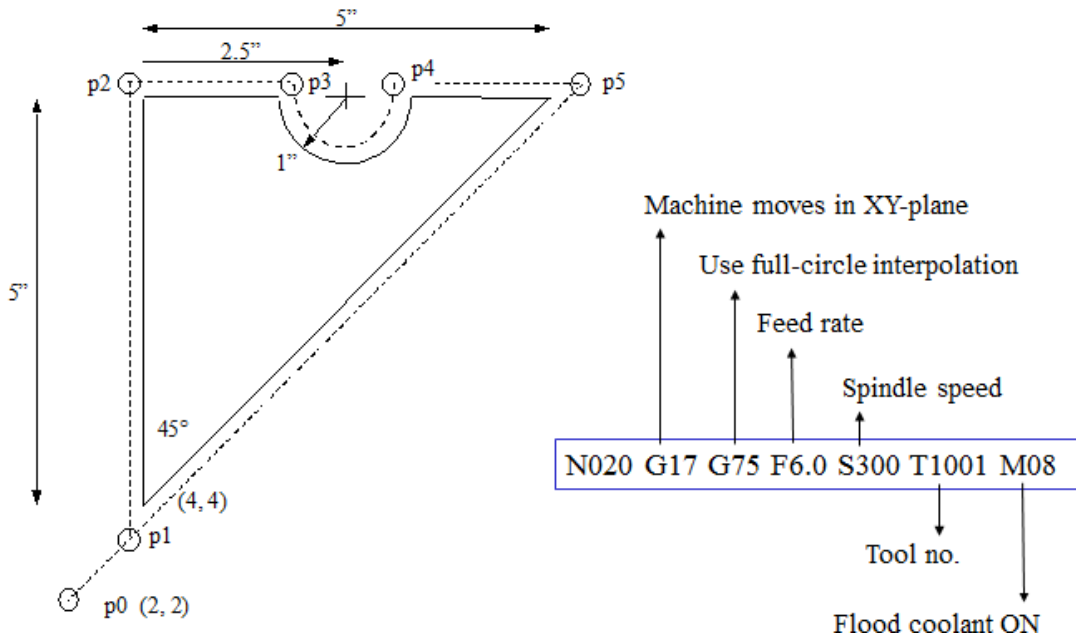


Motion of tool:  
 $p_0 \rightarrow p_1 \rightarrow p_2 \rightarrow p_3 \rightarrow p_4 \rightarrow p_5 \rightarrow p_1 \rightarrow p_0$

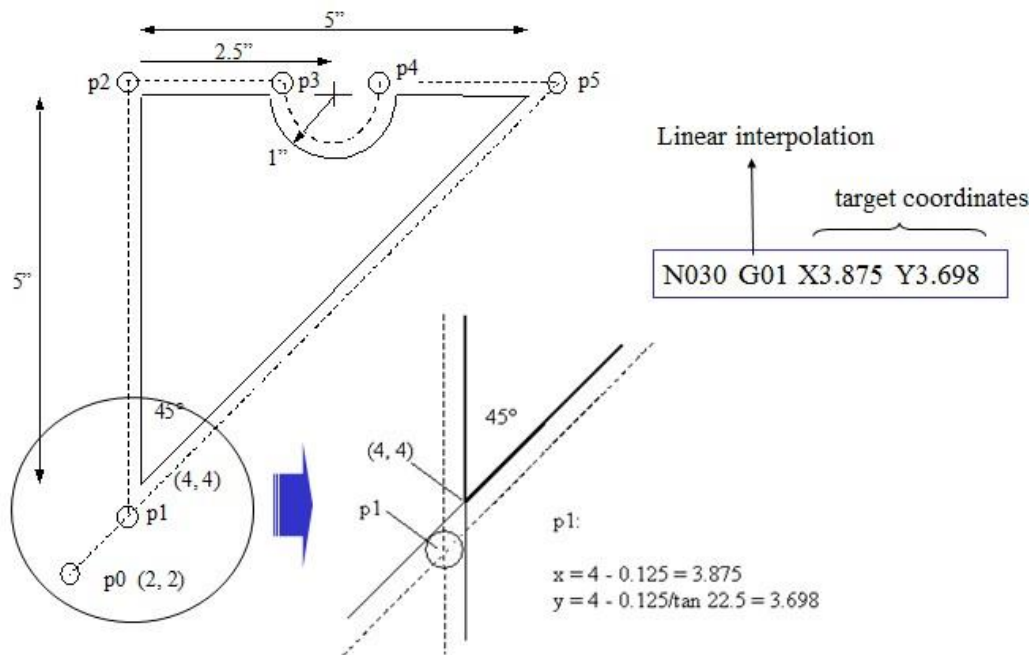
### 1. Set up the programming parameters



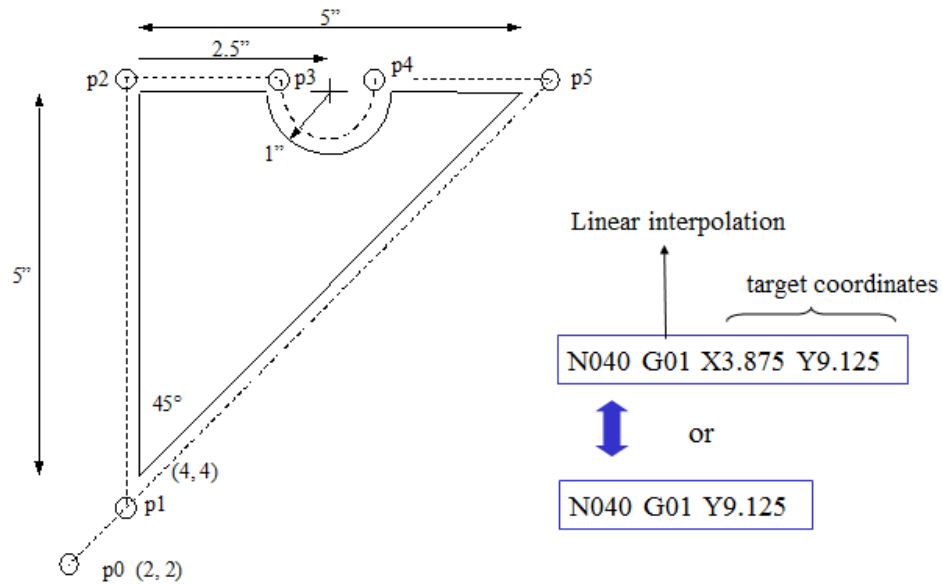
## 2. Set up the machining conditions



## 3. Move tool from p0 to p1 in straight line

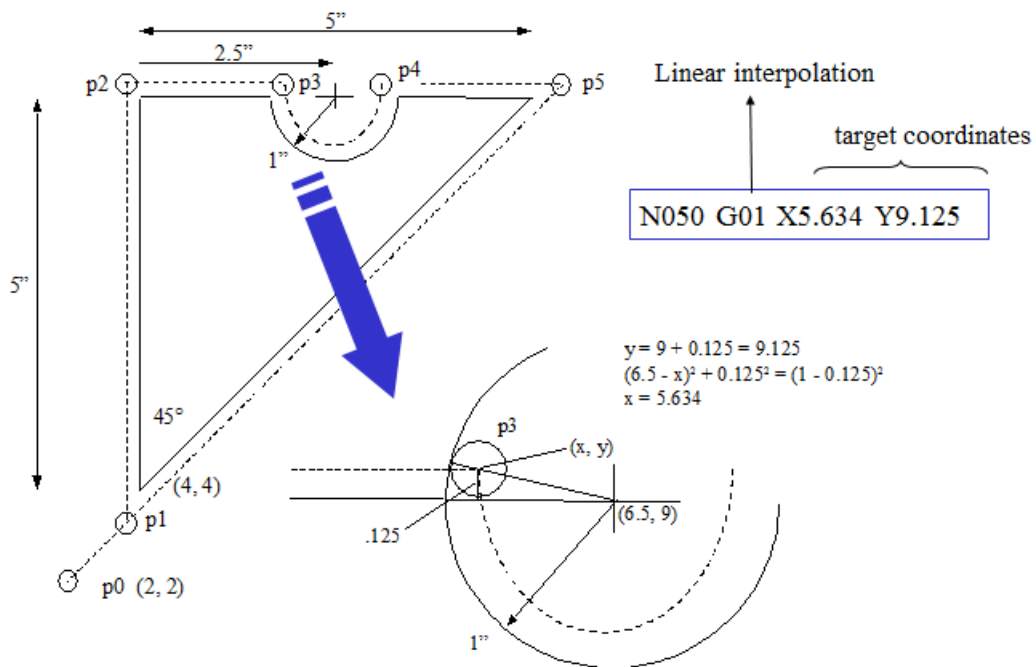


#### 4. Cut profile from p1 to p2

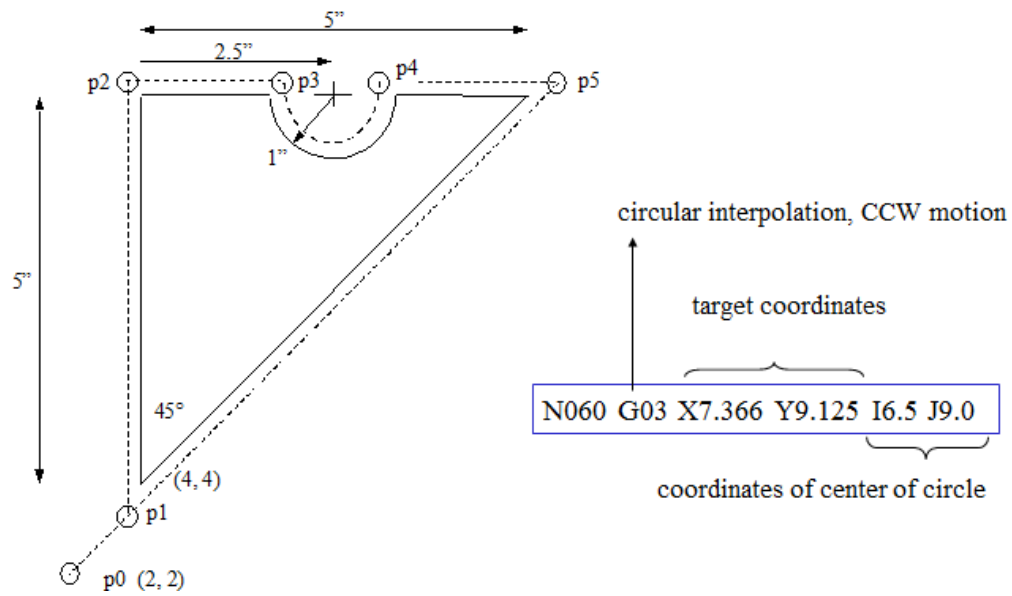


X-coordinate does not change → no need to program it

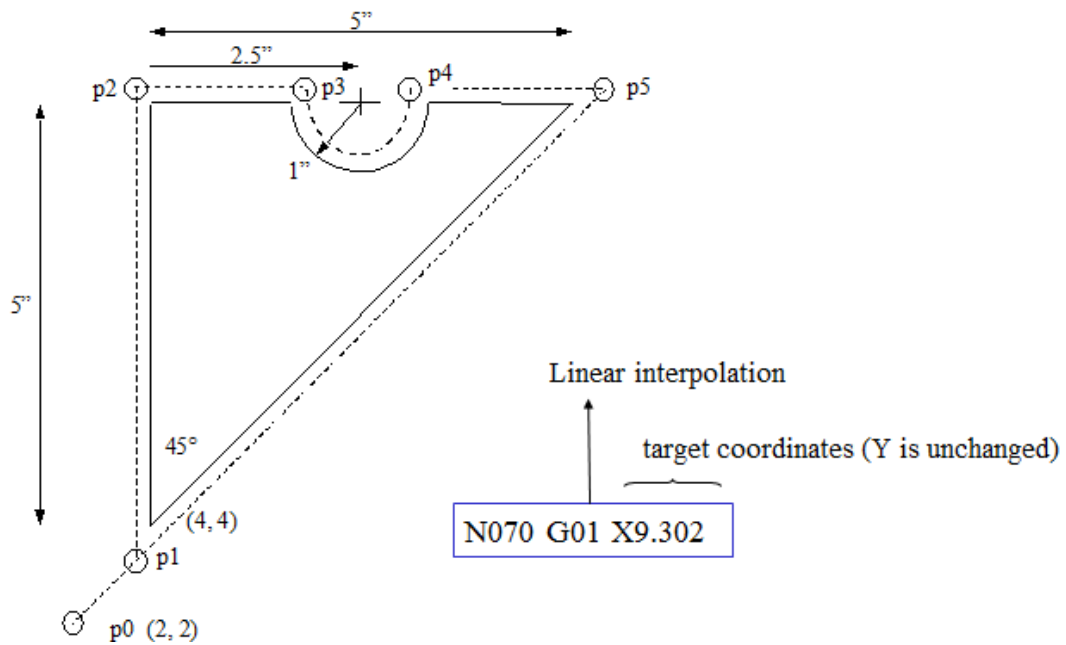
#### 5. Cut profile from p2 to p3



### 6. Cut along circle from p3 to p4

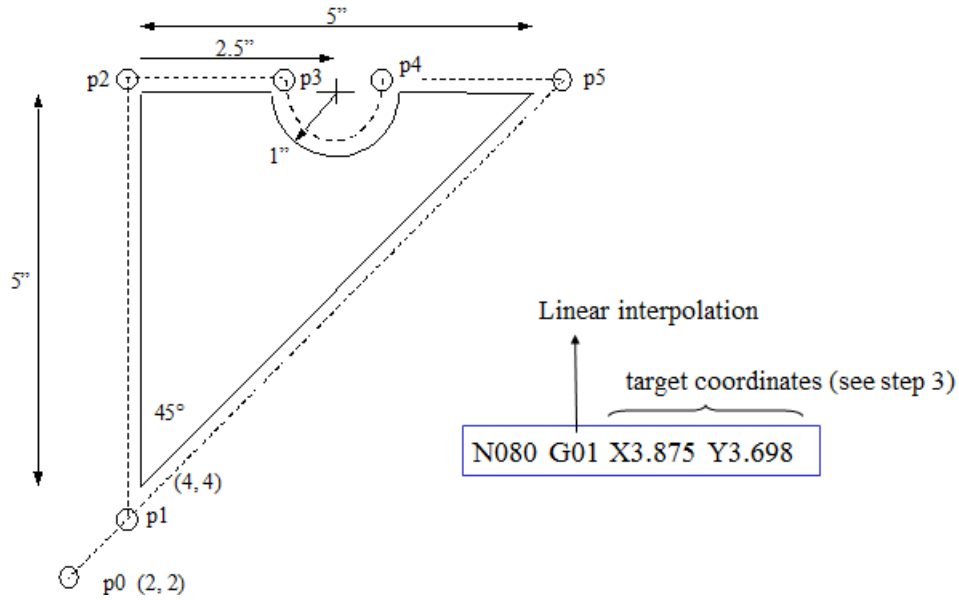


### 7. Cut from p4 to p5

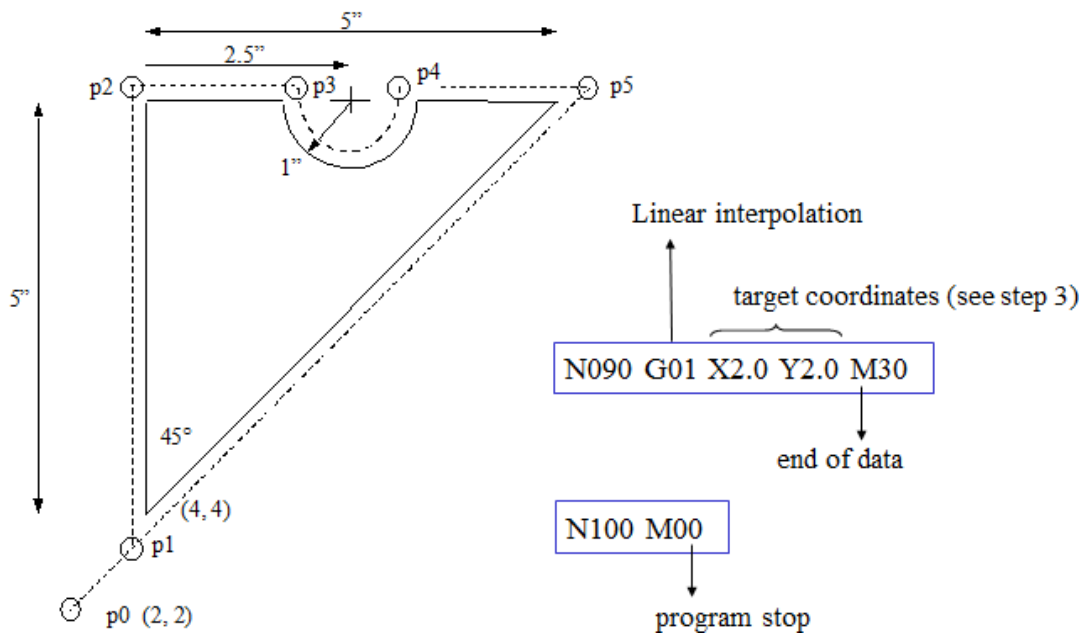




### 8. Cut from p5 to p1



### 9. Return to home position, stop program



The CNC lathe operation such as simple facing, turning, taper turning, thread, boring, parting off etc. The  $X$ -axis and  $Z$ -axis are taken as the direction of transverse motion of the tool post and the axis of the spindle respectively. To prepare part programs using G-codes and M-codes. The following examples illustrated the part program for different components.

**Example**

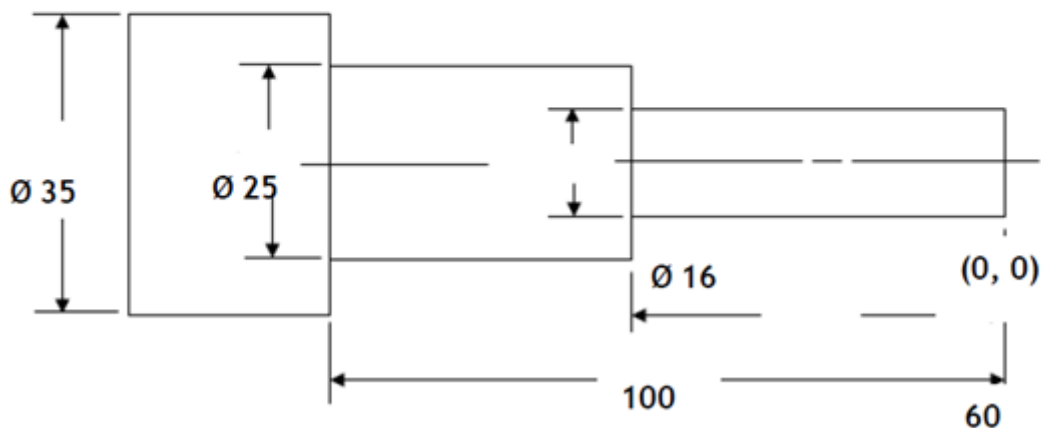


Figure 4.11 : Turning Operation

```
% 1000; (Main programme)
N01 G54 G90 G71 G94 M03 S800; (Parameters Setting)
N05 G01 X-12.5 Z0 F2; (Facing the job)
N10 G00 Z1; (Retrieval of tool)
N15 G00 X00; (Tool clearance)
N20 G01 Z-100; (Starting cut)
N25 G00 X1 Z1; (Clearance position)
N30 G00 X-2; (Position of cut)
N35 G01 Z-60; (Cutting length)
N40 G00 X-1 Z1; (Retrieval of tool)
N45 G00 X-3; (Position of cut)
```

## CAD/CAM/CIM

N50 G01 Z-60; (Cutting length)

N55 G00 X-2 Z1; (Retrieval of tool)

N60 G00 X-4; (Position of cut)

N65 G01 Z-60; (Cutting length)

N70 G00 X-3 Z1; (Retrieval of tool)

N75 G00 X-4.5; (Position of cut)

N80 G01 Z-60; (Cutting length)

N85 G00 X5 Z5; (Final position of tool)

N90 M02; (End of programme)

### **FIXED CYCLE/CANNED CYCLE**

A fixed cycle is a combination of machine moves resulting in a particular machining function such as drilling, milling, boring and tapping. By programming one cycle code number, as many as distinct movements may occur. These movements would take blocks of programme made without using Fixed or Canned cycles. The corresponding instructions of a fixed cycle are already stored in the system memory. The advantages of writing a part programme with these structures are :

- (a) Reduced lengths of part programme.
- (b) Less time required developing the programme.
- (c) Easy to locate the fault in the part programme.
- (d) No need to write the same instructions again and again in the programme.
- (e) Less memory required in the control unit.

The following examples are some basic and fixed cycle codes available with a number of machines, assigned by EIA.

01 (G81 Drilling Cycle) (All dimensions are in mm).

R00 – Dwell time at the starting point for chip removal.

R02 – Reference plane absolute with sign.

R03 – Final depth of hole absolute with sign.

R04 – Dwell time at the bottom of drilled hole for chip breaking.

R10 – Retract plane without sign.

R11 – Drilling axis number 1 to 3.

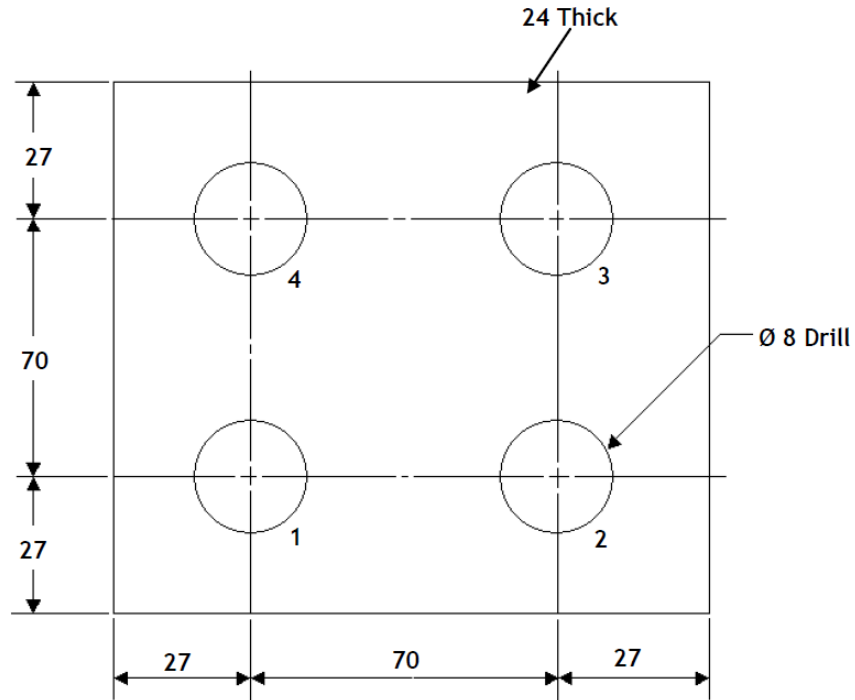


Figure 4.16 : Drilling Cycle

```

N5 G17 G71 G90 G94 G55;
N10 T1 L90;
N15 G00 D5 Z5 M3 S600 X27 Y27;
N20 G81 R02=5, R03=-33, R11=3, F50 M7;
N25 X97;
N30 Y97;
N35 X27;
N40 G00 G80 Z100 M9;
N45 M02;
    
```

**NOTE:** The examples problems are provided in the PPT and pdf file. Its available in the common maild id of your class.

**ME403 CAD/CAM/CIM**

**UNIT 3**

**1 MARKS**

1) Feedback system is used in:

- a) Open loop system
- b) Encoders
- c) Closed loop system
- e) None of above

Ans: Closed loop system

2) „Moiré fringe“ is associated with:

- a) Open loop
- b) Linear scale
- c) Optical encoder
- d) None of the above

Ans: Linear scale

3) M00 stands for

- a) Coolant off
- b) Point to point motion
- c) Coolant on
- d) End of program

Ans: Point to point motion

4) NC contouring is an example:

- a) Continuous path positioning
- b) Absolute positioning
- b) Point-to-point positioning
- c) Incremental positioning

Ans: Continuous path positioning

5) M30 stands for:

- a) End of program
- b) End of tape and tape rewind
- c) End of block
- d) Coolant on/off

Ans: End of tape and tape rewind

6) M06 stands for:

- a) coolant off
- b) Spindle stop
- c) Clamp
- d) Tool change

Ans: coolant off

7) In CNC machine tool the position feedback package is connected between

- a) Control unit and programmer
- b) Control unit and machine tool
- c) Programmer and machine tool
- d) none of the above

Ans: Control unit and machine tool

8) Which one stands for a canned cycle

- a) G19
- b) G81
- c) G02
- d) None of the above

Ans: G81

9) In CNC machine tool the part program entered into the computer memory

- a) Can be used only once
- b) Can be used again but it has to be modified every time
- c) Can be used again and again
- d) cannot say

Ans: Can be used again and again

10) CMM uses the following mechanism to measuring coordinate:

- a) Touch and trigger probe
- b) moiré fringe
- c) rotary encoder
- d) signal from photosensitive object

Ans: Touch and trigger probe

11) G-codes stand for:

- a) Miscellaneous function
- b) Preparatory function
- c) Sequence number
- d) None of the above

Ans: Preparatory function

12) Dwell is defined by

- a) G04
- b) G02
- b) G03
- d) G01

Ans: G04

## 2 MARKS

**1) Identify the necessity of Recirculating ball screw in CNC machine tool.**

Ans: Balls circulate between screw and nut. Balls are recirculated using deflector or return tube. Preloading to reduce backlash.

Advantages

1. Longer life
2. Relatively small wear. Will maintain accuracy through entire life of the screw.
3. Rolling motion reduces friction considerably. Can be used for carrying heavier loads at faster speeds.
4. High efficiency (85-95%)
5. Small power requirement

**2) Distinguish between absolute and incremental coordinate system.**

Ans: Absolute incremental - In this system the origin will be taken as the reference point. All the remaining calculations are done based on this point only.

Incremental system - In this system origin will not be considered as reference point always. All the calculations are done based on the previous occupied point.

**3) Discuss 'cutter radius compensation'.**

Ans: Cutter radius compensation- In contouring operations, it becomes necessary to calculate the tool path for preparing by offsetting the contour by an amount equal to radius of the cutter. A compensation equal to the radius of the cutter is entered and stored in the control system, then the program could be written for the component profile and thus no change in the program would be required.

**4) Explain ‘machine zero’ and ‘work zero’.**

Ans: Machine zero: - It is the built in location of each CNC machine. It is the farthest positive direction along x-y-z axes. Cannot be changed by the user. Loading and unloading of parts will be done at this point.

Work zero:- Starting location of the program. It is termed as the origin. All the other calculation are based on this origin. It can be fixed or floating. Fixed means normally bottom left hand corner. Floating means it can be set by the operator anywhere on the machine table.

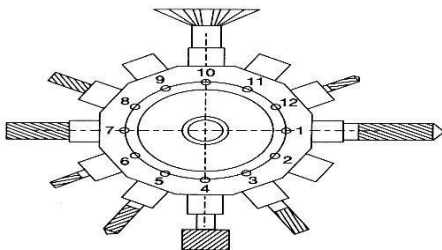
**5) Define canned cycle.**

Ans: Canned cycle: - Sometimes a series of operations are to be repeated a number of times, many of which are common to all the positions. Therefore it is possible to define a fixed cycle which can repeat all these motions without having to repeat the same information are called canned cycle. The most common cycles that are useful are for the hole-making operations as drilling, reaming, tapping etc.

**6) Discuss a) Tool magazine. b) Tool turrets? Explain with a neat sketch.**

Ans: Tool magazine- It is the place where sufficient number of tool for CNC machining has been stored. Storage capacity starts with about 12 and ga high as 200 while 30 to 60 to be the most common.

Tool turret: - It is the simplest type of tool magazine. This method combines tool storage with the tool exchange procedure.



**Fig. 11.14** Typical tool turret used in CNC drilling/milling machines

**7) Differentiate between M-codes and G-codes**

Ans: M-codes- These functions actually operate some controls on the machine tool and thus affect the running of the machine. Generally only one M code is supposed to be given in a single block.eg M01-coolant ON, M03-Spindle on

G-code- It is preset function associated with the movement of machine axes and the associated geometry. Eg- G01-line interpolation, G43-cutter compensation (positive).

**8) Define APC.**

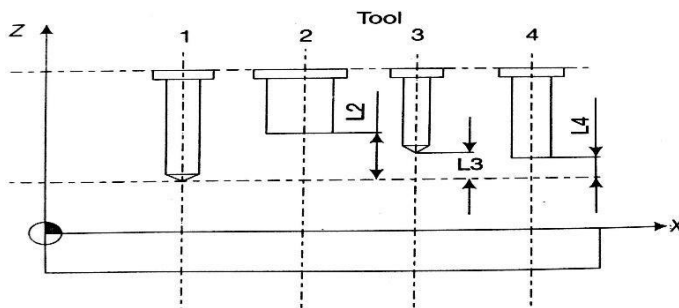
Ans: Automatic Pallet Changer: - While machining is being performed with one pallet in position at the machine, the other pallet is in a safe location away from the spindle. In this safe location the operator can unload the finished part from the prior cycle and then fixture the raw work part for the next cycle while the current work piece is being machined.

**9) Write short note on the concept of ATC.**

Ans: Automatic Tool Changer:- When a cutter needs to be changed, the tool drum rotates to the proper position, and an automatic tool changer (ATC), operating under part program control, exchanges the tool in the spindle for the tool in the tool storage unit. Capacities of the tool storage unit commonly range from 16 to 80 cutting tools.

**10) Define the terminology Tool length compensation**

Ans: The difference in length with respect to the presetting tool is recorded and is manually entered and stored. Whenever the tools are called into action the compensation value is activated and automatically taken into account in the tool motion.



**Fig. 13.26** Tool-length compensation

**11) Discuss on the importance of feedback system in closed loop system.**

Ans: In CNC machine tool feedback system is enabled in closed loop control system. Feedback system gives us the comparison of output with input so that if there is any deviation from the required output it will be automatically rectified. It assure higher accuracy. Complex parts can be manufactured with higher accuracy.

**12) Explain about CMM.**

Ans: CMM is coordinate measuring machine in which at the end of the structure a prob will be fixed. When the probe touches the work it trigger a signal. Base on the triggered signal the coordinates of the part will be identified.

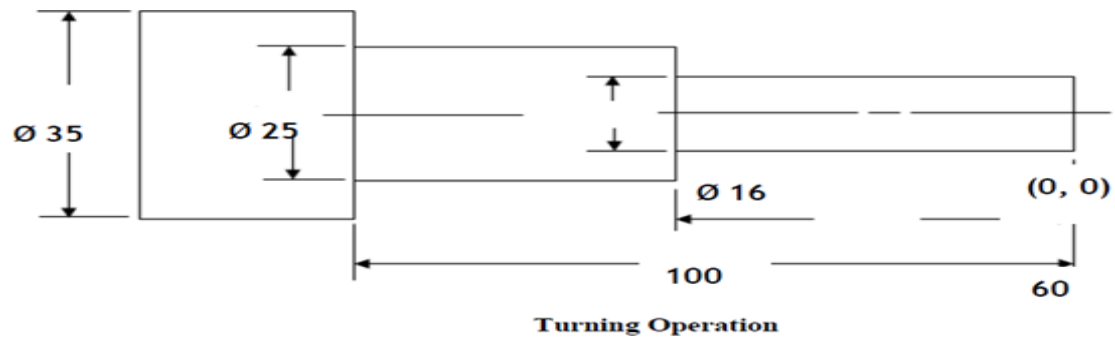
**13) Define open loop control system.**

Ans: Open loop- There is no feedback system to measure the output. Accuracy cannot be predicted. There is no mechanism to correct the process if the output went wrong. Used to manufacture less critical part.

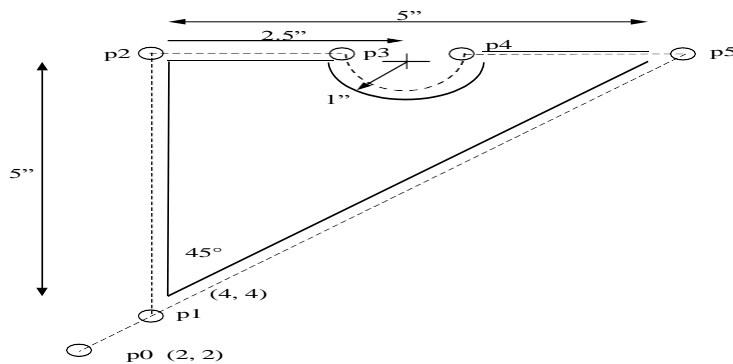


**14 MARKS**

- 1) Explain the construction, working principle and specifications of Coordinate measuring machine.
- 2) Define CNC EDM. Explain the working principle of a CNC EDM machine with a neat sketch.
- 3) Explain the working principle of linear scale with neat sketch.
- 4) Distinguish between open loop and closed loop control system with neat sketch.
- 5) Distinguish between 2-axes contouring and 3-axes contouring with neat sketches?
- 6) Explain the working principle of rotary encoders with neat sketch.
- 7) Write CNC part program for the following job



- 8) Write part program for the following job.



- 9) Explain briefly about the main elements in Numerical Control.
- 10) Classify different types of motion control in CNC? Explain each with neat sketches.
- 11) Describe briefly about microprocessor based CNC system.
- 12) Define Interpolation. What are the types? Explain with a neat sketch.
- 13) Explain briefly about canned cycle in drilling operation with an example.
- 14) Explain briefly about macro and subroutines.
- 15) Discuss on pneumatic and hydraulic control systems.
- 16) Explain about the microprocessor based CNC systems.

## UNIT IV - FLEXIBLE MANUFACTURING SYSTEMS

### Syllabus

Basic Elements of an Automated -system – Levels of Automation – Lean Production and Just-In-Time Production. Concurrent Engineering - FMS-components of FMS - types -FMS workstation -material handling and storage systems- FMS layout -application and benefits

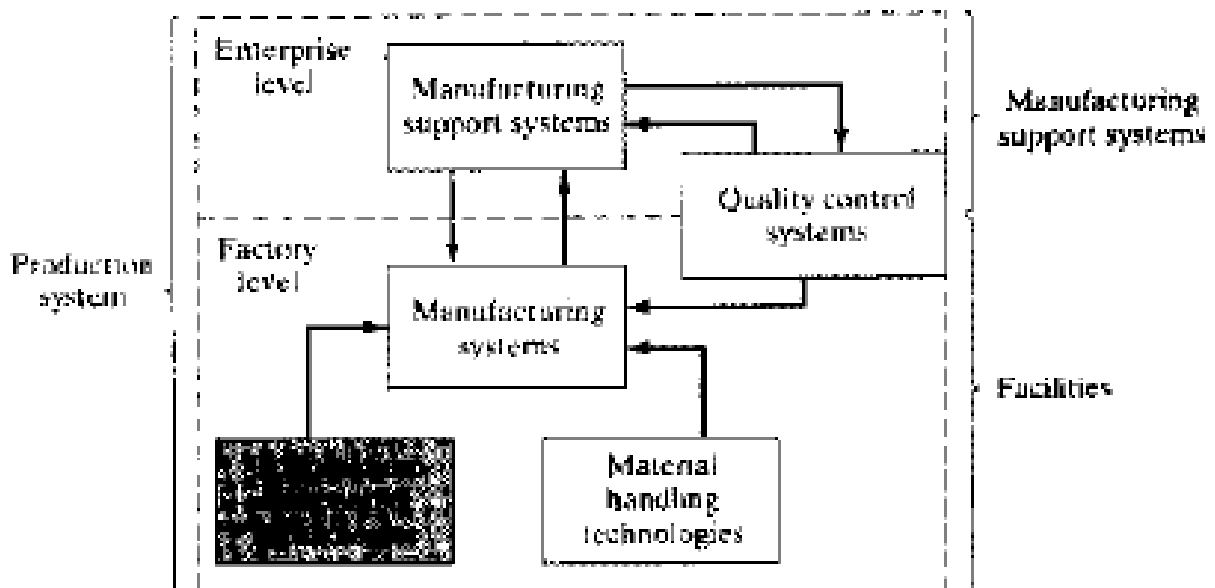
### Books-

1. AUTOMATION PRODUCTION -SYSTEMS-CIM BY GROOVER

# Automation

## 4.1 What is automation

Automation is the technology by which a process or procedure is accomplished without human assistance. It is implemented using a program of instructions combined with a control system that executes the instructions, to automate a process. Power is required, both to drive the process itself and to operate the program and control system. Although automation can be applied in a wide variety of areas, it is most closely associated with the manufacturing industries. It was in the context of manufacturing that the term was originally coined by an engineering manager at Ford Motor Company in 1946 to describe the variety of automatic transfer devices and feed mechanisms that had been installed in Ford's production plants. It is ironic that nearly all modern applications of automation are controlled by computer technologies that were not available in 1946.



**Figure 3.1** Automation and control technologies in the production system.

### Basic elements of an automated system

An automated system consists of three basic elements:

- (1) Power to accomplish the process and operate the system.
- (2) A program of instructions to direct the process, and
- (3) A control system to actuate the instructions.

## 1. Power to Accomplish the Automated Process

An automated system is used to operate some process, and power is required to drive the process as well as the controls. The principal source of power in automated systems is electricity. Electric power has many advantages in automated as well as non-automated processes. Electrical power is widely available at moderate cost. It is an important part of our industrial infrastructure. Electrical power can be readily converted to alternative energy forms: mechanical, thermal, light, acoustic, hydraulic, and pneumatic.

Electrical power at low levels can be used to accomplish functions such as signal transmission, information processing, and data storage and communication. Electrical energy can be stored in long-life batteries for use in locations where an external source of electrical power is not conveniently available.

An alternative power sources are shown in table.

**TABLE 3.1** Common Manufacturing Processes and Their Power Requirements

<i>Process</i>	<i>Power Form</i>	<i>Action Accomplished</i>
Casting	Thermal	Melting the metal before pouring into a mold cavity where solidification occurs.
Electric discharge machining (EDM)	Electrical	Metal removal is accomplished by a series of discrete electrical discharges between electrode (tool) and workpiece. The electric discharges cause very high localized temperatures that melt the metal.
Forging	Mechanical	Metal workpart is deformed by opposing dies. Workparts are often heated in advance of deformation, thus thermal power is also required.
Heat treating	Thermal	Metallic work unit is heated to temperature below melting point to effect microstructural changes.
Injection molding	Thermal and mechanical	Heat is used to raise temperature of polymer to highly plastic consistency, and mechanical force is used to inject the polymer melt into a mold cavity.
Laser beam cutting	Light and thermal	A highly coherent light beam is used to cut material by vaporization and melting.
Machining	Mechanical	Cutting of metal is accomplished by relative motion between tool and workpiece.
Sheet metal punching and blanking	Mechanical	Mechanical power is used to shear metal sheets and plates.
Welding	Thermal (maybe mechanical)	Most welding processes use heat to cause fusion and coalescence of two (or more) metal parts at their contacting surfaces. Some welding processes also apply mechanical pressure to the surfaces.

## 2. Program of Instructions

The actions performed by an automated process are defined by a program of instructions. Whether the manufacturing operation involves low, medium, or high production, each part or product style made in the operation requires one or more processing steps that are unique to that style, these processing steps are performed during a work cycle.

A new part is completed during each work cycle (in some manufacturing operations, more than one part is produced during the work cycle; e.g., a plastic injection molding operation may produce multiple parts each cycle using a multiple cavity mold). The particular processing

steps for the work cycle are specified in a work cycle program. Work cycle, programs are called part programs in numerical control. Other process control applications use different names for this type of program.

**TABLE 3.2** Features of Work Cycle Programs Used in Automated Systems

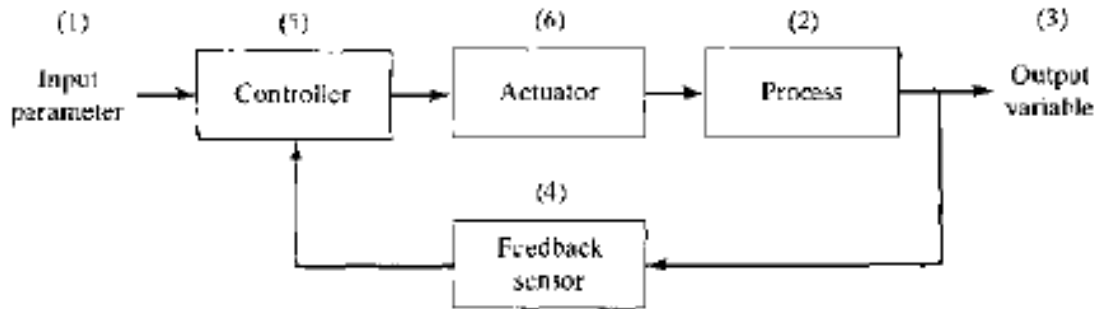
<i>Program Feature</i>	<i>Examples or Alternatives</i>
Steps in work cycle	Example: • Typical sequence of steps: (1) load, (2), process, (3) unload
Process parameters (inputs) in each step	Alternatives: • One parameter versus multiple parameters that must be changed during the step • Continuous parameters versus discrete parameters • Parameters that change during the step; for example, a positioning system whose axes values change during the processing step
Manual steps in work cycle	Alternatives: • Manual steps versus no manual steps (completely automated work cycle) Example: • Operator loading and unloading parts to and from machine
Operator interaction	Alternatives: • Operator interaction versus completely automated work cycle Example: • Operator entering processing information for current workpart
Different part or product styles	Alternatives: • Identical part or product style each cycle (mass or batch production) versus different part or product styles each cycle (flexible automation)
Variations in starting work units	Example: • Variations in starting dimensions or part features

A variety of production situations and work cycle programs has been discussed here. The features of work cycle programs (part programs) used to direct the operations of an automated system are summarized as in Table 3.2.

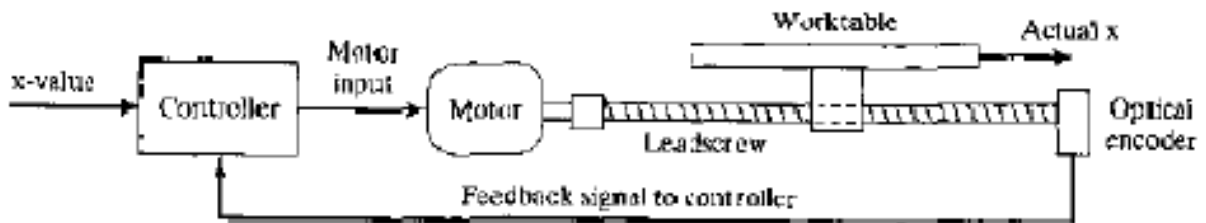
### 3. Control System

The control element of the automated system executes the program of instructions. The control system causes the process to accomplish its defined function. Which for our purpose is to carry out some manufacturing operation. Let us provide a brief introduction to control systems here.

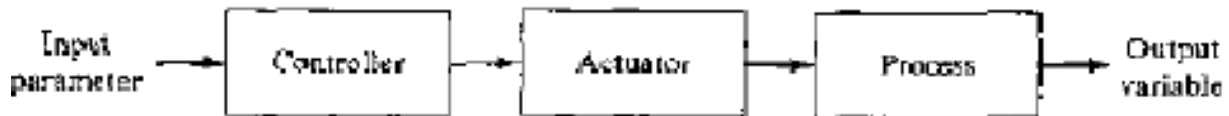
The controls is an automated system can be either closed loop or open loop. A closed loop control system, also known as a feedback control system, is one in which the output variable is compared with an input parameter, and any difference between the two is used to drive the output into agreement with the input. As shown in Figure 3.3. A closed loop control system consists of six basic elements: (1) input parameter, (2) process, (3) output variable, (4) feedback sensor, (5) Controller. And (0) actuator. The input parameter. Often referred to as the set point, represents the desired value of the output.



**Figure 3.3** A feedback control system.



**Figure 3.5** A (one-axis) positioning system consisting of a leadscrew driven by a dc servomotor.



**Figure 3.4** An open loop control system.

## 4.2 Advanced automation functions

In general, the functions are concerned with enhancing the performance and safety of the equipment. Advanced automation functions include the following:

- (1) Safety monitoring,
- (2) Maintenance and repair diagnostics, and
- (3) Error detection and recovery.

### Safety monitoring

There are two reasons for providing an automated system with a safety monitoring capability:

- To protect human workers in the vicinity of the system and
- To protect the equipment associated with the system.
- Limit switches to detect proper positioning of a part in a work holding device so that the processing cycle can begin.

- Photoelectric sensors triggered by the interruption of a light beam; this could be used to indicate that a part is in the proper position or to detect the presence of a human intruder into the work cell.
- Temperature sensors to indicate that a metal work part is hot enough to proceed with a hot forging operation. If the work part is not sufficiently heated, then the metal's ductility may be too low, and the forging dies might be damaged during the operation.
- Heat or smoke detectors to sense fire hazards.
- Pressure-sensitive floor pads to detect human intruders into the work cell.
- Machine vision systems to supervise the automated system and its surroundings.

### Maintenance and Repair Diagnostics

- Status monitoring system
- Failure diagnostics.
- Recommendation of repair procedures.

### Error Detection.

- Error Detection. A, indicated by the term. error detection and recovery consists of Two steps: (1) error detection and (2) error recovery.
- The error deflection step uses the automated system's available sensor systems to determine when a deviation or malfunction has occurred, correctly interpret the sensor signal(s), and classify-the error. Design of the error detection subsystem must begin with a classification of the possible errors that can occur during system operation. The errors in a manufacturing process tend to be very application specific.
- In analyzing a given production operation, the possible errors can be classified into one of three general categories:

(1) Random errors, large variations in part dimensions, even when the production process is in statistical

(2) Systematic errors, control, these errors usually cause the product to deviate from specifications so as to be unacceptable in quality terms.

(3) Aberrations errors, results from either an equipment failure or a human mistake.

### Error Recovery

- Error recovery is concerned with applying the necessary corrective action to overcome the error and bring the system back to normal operation.
- Make adjustments at the end of the current work cycle.
- Stop the process to invoke corrective action.
- Stop the process and call for help.

### 4.3 LEVELS OF AUTOMATION

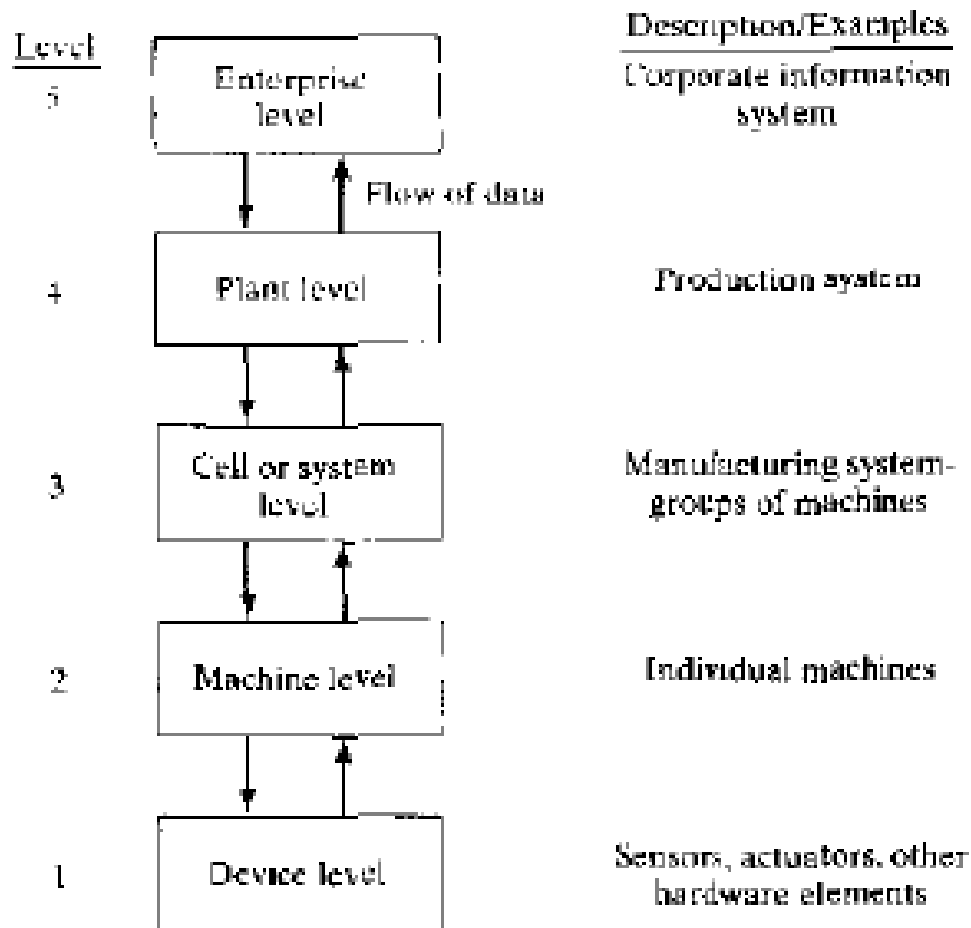
#### Device level.

This is the lowest level in our automation hierarchy. It includes the actuators, sensors, and other hardware components that comprise the machine level.

The devices are combined into the individual control loops of the machine; for example, the feedback control loop for one axis of a CNC machine or one joint of an industrial robot.

#### Machine level.

Hardware at the device level is assembled into individual machines. Examples include CNC machine tools and similar production equipment, industrial robots, powered conveyors, and automated guided vehicles. Control functions at this level include performing the sequence of steps in the program of instructions in the correct order and making sure that each step is properly executed.



**Figure 3.6** Five levels of automation and control in manufacturing.



**Cell or system level.**

This is the manufacturing cell or system level, which operates under instructions from the plant level. A manufacturing cell or system is a group of machines or workstations connected and supported by a material handling system, computer. And other equipment appropriate to the manufacturing process. Production lines are included in this level. Functions include part dispatching and machine loading. Coordination among machines and material handling system, and collecting and evaluating inspection data.

**Plant level.**

This is the factory or production systems level. It receives instructions from the corporate information system and translates them into operational plans for production. Likely functions include: order processing, process planning, inventory control, purchasing, material requirements planning, shop floor control, and quality control.

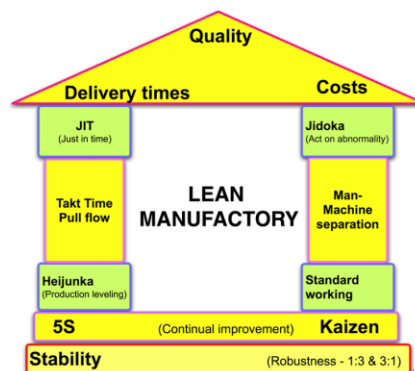
**Enterprise level.**

This is the highest level consisting of the corporate information system. It is concerned with all of the functions necessary to manage the company: marketing and sales, accounting, design, research, aggregate planning, and master production scheduling.

**4.4 Lean manufacturing or lean production,**

Lean manufacturing or lean production, often simply "lean", is a systematic method for the elimination of waste ("Muda") within a manufacturing system. Lean also takes into account waste created through overburden ("Muri") and waste created through unevenness in workloads ("Mura"). Working from the perspective of the client who consumes a product or service, "value" is any action or process that a customer would be willing to pay for.

Essentially, lean is centered on *making obvious what adds value by reducing everything else*. Lean manufacturing is a management philosophy derived mostly from the **Toyota Production System** (TPS) (hence the term Toyotism is also prevalent) and identified as "lean" only in the 1990s. TPS is renowned for its focus on reduction of the original Toyota *seven wastes* to improve overall customer value, but there are varying perspectives on how this is best achieved. The steady growth of **Toyota**, from a small company to the world's largest automaker,<sup>[3]</sup> has focused attention on how it has achieved this success.



## 4.5 JUST-IN-TIME production systems

Just-in-time (JIT) production systems were developed in Japan to minimize inventories, especially WIP and other types of inventory are seen by the Japanese as waste that should be minimized or eliminated, The ideal just-in-time production system produces and delivers exactly the required number of each component to the downstream operation in the manufacturing sequence just at the time when that component is needed. Each component is delivered "just in time."

This delivery discipline minimizes WIP and manufacturing lead time as well as the space and money invested in WIP. The JIT discipline can be applied not only to production operations but to supplier delivery operations as well.

### Pull system

- JIT is based on a **pull system** of production control, in which the order to make and deliver parts at each workstation in the, production sequence comes from the downstream station that uses those parts. When the supply of parts at a given workstation is about to be exhausted. that station orders the upstream station to replenish the supply. Only on receipt of this order is the upstream station authorized to produce the needed parts.

### Push system

- When this procedure is repeated at each workstation throughout the plant, it has the effect of pulling parts through the production system. By comparison, in a **push system** of production control, parts at each workstation are produced irrespective of the immediate need for the parts at its respective downstream station. In effect, this production discipline pushes parts through the plant. The risk in a push system is that more work gets scheduled in the factory than it can handle, resulting in large queues of parts in front of machines. The machines are unable to keep up with arriving work. and the factory becomes overloaded. A poorly planned MRP-based production planning system that does not include capacity planning runs this risk.

### Kanban

One way to implement a pull system is to use kanbans, The word kanban (pronounced kahn-bahn ) means "card" in Japanese, The Kanban system of production control, developed and made famous by Toyota, the Japanese automobile company, is based on the use of cards that authorize (1) parts production and (2) parts delivery in the plant. Thus, there are two types of kanbans:

- (1) production kanban and (2) transport kanban.

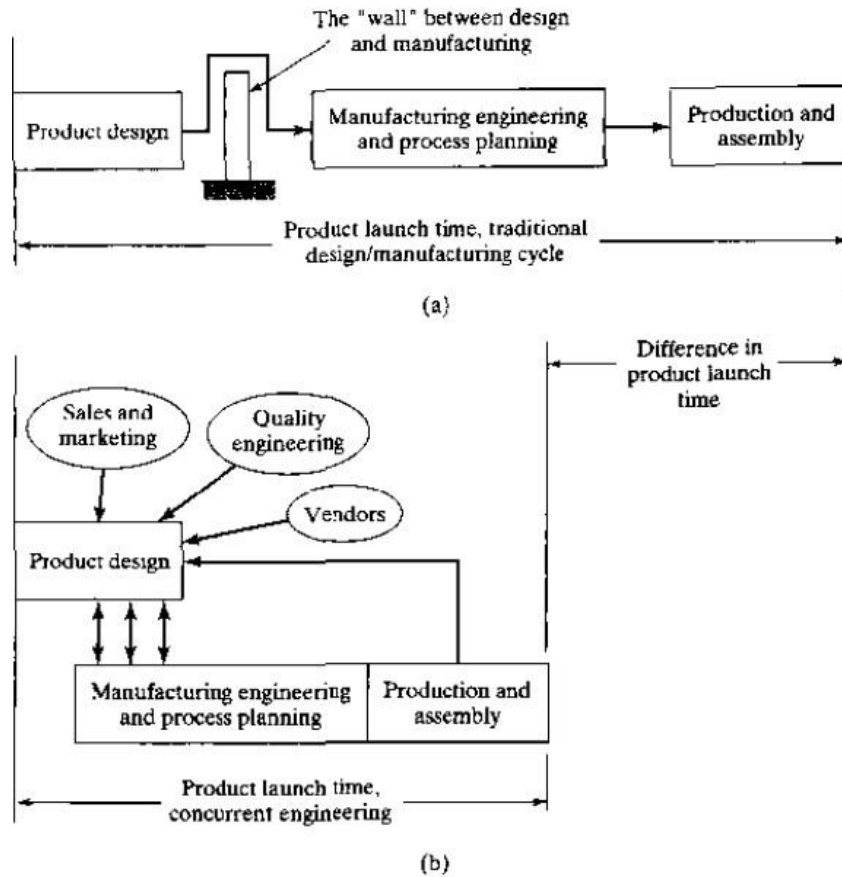
### Production kanban and transport kanban

A production kanban (P-kanban) authorizes the upstream station to produce a batch of parts. As they are produced. the parts are placed in containers. so the batch quantity is just sufficient to fill the container. Production of more than this quantity of parts is not allowed in the

kanban system. A transport kanban (T-kanban) authorizes transport of the container of parts to the downstream station.

### 4.6 Concurrent engineering

Concurrent engineering refers to an approach used in product development in which the functions of design engineering, manufacturing engineering, and other functions are integrated to reduce the elapsed time required to bring a new product to market. Also called simultaneous engineering, it might be thought of as the organizational counterpart to CAD/CAM technology. its shown in fig.



**Figure 25.5** Comparison of: (a) traditional product development cycle and (b) product development using concurrent engineering.

Concurrent engineering include several elements: (1) design for manufacturing and assembly (2) design for quality (3) design for cost (4) design for life cycle. in addition certain enabling technologies such as rapid prototyping, virtual prototyping and organizational changes are required to facilitate the concurrent engineering approach in a company

## 4.7 FMS (Flexible Manufacturing Systems)

A flexible manufacturing system (FMS) is a highly automated GT (Group technology) machine cell. Consisting of a group of processing workstations (usually CNC machine tools), inter connected by an automated material handling and storage system, and controlled by a distributed computer system. The reason the FMS is called flexible is that it is capable of processing a variety of different part styles simultaneously at the various workstations, and the mix of part styles and quantities of production can be adjusted in response to changing demand patterns.

The FMS is most suited for the mid-variety, mid-volume production range

**TABLE 16.1** Types of Flexibility in Manufacturing. These Concepts of Flexibility Are Not Limited to Flexible Manufacturing Systems. They Apply to Both Manned and Automated Systems. Sources: [3], [7], [23], [26]

<i>Flexibility Type</i>	<i>Definition</i>	<i>Depends on Factors Such As:</i>
<b><i>Machine flexibility</i></b>	Capability to adapt a given machine (workstation) in the system to a wide range of production operations and part styles. The greater the range of operations and part styles, the greater the machine flexibility.	Setup or changeover time. Ease of machine reprogramming (ease with which part programs can be downloaded to machines). Tool storage capacity of machines. Skill and versatility of workers in the system.
<b><i>Production flexibility</i></b>	The range or universe of part styles that can be produced on the system.	Machine flexibility of individual stations. Range of machine flexibilities of all stations in the system.
<b><i>Mix flexibility</i></b>	Ability to change the product mix while maintaining the same total production quantity; that is, producing the same parts only in different proportions.	Similarity of parts in the mix. Relative work content times of parts produced. Machine flexibility.
<b><i>Product flexibility</i></b>	Ease with which design changes can be accommodated. Ease with which new products can be introduced.	How closely the new part design matches the existing part family. Off-line part program preparation. Machine flexibility.

<b>Routing flexibility</b>	Capacity to produce parts through alternative workstation sequences in response to equipment breakdowns, tool failures, and other interruptions at individual stations.	Similarity of parts in the mix. Similarity of workstations. Duplication of workstations. Cross-training of manual workers. Common tooling.
<b>Volume flexibility</b>	Ability to economically produce parts in high and low total quantities of production, given the fixed investment in the system.	Level of manual labor performing production. Amount invested in capital equipment.
<b>Expansion flexibility</b>	Ease with which the system can be expanded to increase total production quantities.	Expense of adding workstations. Ease with which layout can be expanded. Type of part handling system used. Ease with which properly trained workers can be added.

Flexible manufacturing systems can be distinguished according to the kinds of operations they perform : (1) processing operations or (2) assembly operations

Two other ways to classify FMSs are by: (1) number of machines and (2) level Of flexibility.

#### 4.8 Types of FMS

Flexible manufacturing systems can be divided into various types depending upon their features. They all are discussed below:

##### 1. Depending upon level of flexibility.

FMS is made according to the level of flexibility associated with the system. Two categories are distinguished here:

I. **Dedicated FMS.** It is designed to produce a particular variety of part styles. The product design is considered fixed. So, the system can be designed with a certain amount of process specialization to make the operation more efficient.

II. **Random order FMS.** It is able to handle the substantial variations in part configurations. To accommodate these variations, a random order FMS must be more flexible than the dedicated FMS. A random order FMS is capable of processing parts that have a higher degree of complexity. Thus, to deal with these kinds of complexity, sophisticated computer control system is used for this FMS type. Production rate annual volume

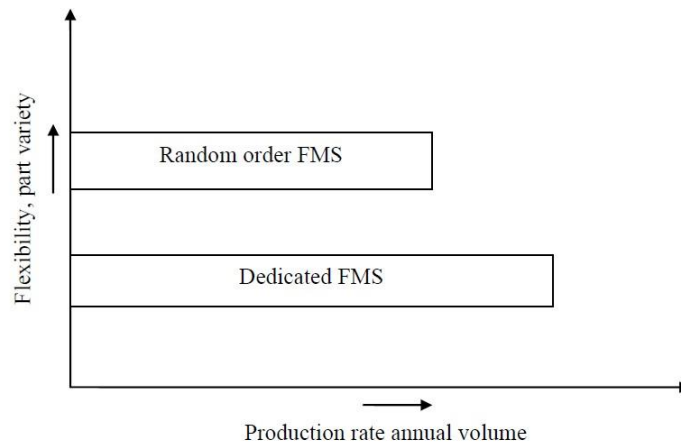


Figure 6.3 differences between dedicated and random-order FMS types

As indicated in our definition, there are several basic components of an FMS. In the following segment, a framework for understanding the components of an FMS is presented. A flexible manufacturing system consists of two subsystems:

Physical subsystem

Control subsystem

Physical subsystem includes the following elements:

1. **Workstations.** It consists of NC machines, machine-tools, inspection equipment's, loading and unloading operation, and machining area.
2. **Storage-retrieval systems.** It acts as a buffer during WIP (work-in-processes) and holds devices such as carousels used to store parts temporarily between work stations or operations.
3. **Material handling systems.** It consists of power vehicles, conveyers, automated guided vehicles (AGVs), and other systems to carry parts between workstations.

## 2. Depending Upon Kinds Of Operation-

Flexible manufacturing system can be distinguished depending upon the kinds of operation they perform:

I. **Processing operation.** Such operation transforms a work material from one state to another moving towards the final desired part or product. It adds value by changing the geometry, properties or appearance of the starting materials.

II. **Assembly operation.** It involves joining of two or more component to create a new entity which is called an assembly/subassembly. Permanent joining processes include welding, brazing, soldering, adhesive bonding, rivets, press fitting, and expansion fits.

## 2. Depending upon number of machines –

The following are typical categories of FMS according to the number of machines in the system:

**I. single machine cell (SMC).** It consist of a fully automated machine capable of unattended operations for a time period longer than one machine cycle. It is capable of processing different part styles, responding to changes in production schedule, and accepting new part introductions. In this case processing is sequential not simultaneous.

**II. Flexible manufacturing cell (FMC).** It consists of two or three processing workstation and a part handling system. The part handling system is connected to a load/unload station. It is capable of simultaneous production of different parts.

**III. A Flexible Manufacturing System (FMS).** It has four or more processing work stations (typically CNC machining centers or turning centers) connected mechanically by a common part handling system and automatically by a distributed computer system. It also includes non-processing work stations that support production but do not directly participate in it. e.g. part / pallet washing stations, co-ordinate measuring machines. These features significantly differentiate it from Flexible manufacturing cell (FMC).

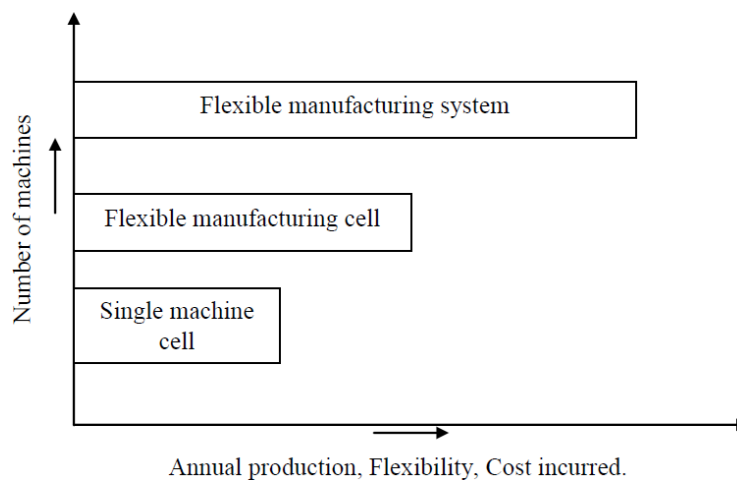


Figure 6.2 Comparison for three categories of FMS

## 4.9 FMS COMPONENTS

As indicated in our definition there are several basic components of an FMS:

- (1) Workstations,
- (2) Material handling and storage system, and
- (3) Computer control system. In addition, even though an FMS is highly automated,
- (4) People are required to manage and operate the system. We discuss these four FMS components in this section.

## 1. Workstations

The processing or assembly equipment used in an FMS depends on the type of work accomplished by the system. In a system designed for machining operations, the principle types of processing station are CNC machine tools. However, the FMS concept is also applicable to various other processes as well. Following are the types of workstations typically found in an FMS.

**a. Load/Unload Stations.** The load/unload station is the physical interface between the FMS and the rest of the factory. Raw work parts enter the system at this point, and finished parts exit the system from here. Loading and unloading can be accomplished either manually or by automated handling systems. Manual loading and unloading is prevalent in most FMSs today. The load/unload station should be ergonomically designed to permit convenient and safe movement of work parts. For parts that are too heavy to lift by the operator, mechanized cranes and other handling devices are installed to assist the operator.

### **b. Machining Stations.**

The most common applications of FMSs are machining operations. The workstations used in these systems are therefore predominantly CNC machine tools. Most common is the CNC machining center in particular. the horizontal machining center.

CNC machining centers possess features that make them compatible with the FMS, including automatic tool changing and tool storage, use of palletized Work parts, CNC and capacity for distributed numerical control (DNC) Machining centers can be ordered with automatic pallet changers that can be readily interfaced with the FMS part handling system. Machining centers are generally used for non rotational parts. For rotational parts, turning centers are used; and for parts that are mostly rotational but require multitooth rotational cutters (milling and drilling), mill-turn centers can be used.

**C. Other Processing Stations.** The FMS concept has been applied to other processing operations in addition to machining. One such application is sheet metal fabrication processes, reported in the processing workstations consist of press working operations, such as punching, shearing, and certain bending and forming processes. Also, flexible systems are being developed to automate the forging process. Forging is traditionally a very labor-intensive operation. The workstations in the system consist principally of a heating furnace, a forging press. and a trimming station.

**d. Assembly.** Some FMSs are designed to perform assembly operations. Flexible automated assembly systems are being developed to replace manual labor in the assembly of products typically made in batches. Industrial robots are often used as the automated workstations in these flexible assembly systems. They can be programmed to perform tasks with variations in sequence and motion pattern to accommodate the different product styles assembled in the system. Other examples of flexible assembly workstations are the programmable component placement machines widely used in electronics assembly.

**Other Stations and Equipment.** Inspection can be incorporated into an FMS, either by including, an inspection operation at a processing workstation or by including a station specifically



designed for inspection. Coordinate measuring machines special inspection probes that can be used in a machine tool spindle and machine vision are three possible technologies for performing inspection on an FMS. Inspection has been found to be particularly important in flexible assembly systems to ensure that components have been properly added at the workstations.

## 2. Material Handling and Storage System

The second major component of an FMS is its material handling and storage system. In this subsection, we discuss the functions of the handling system, material handling equipment typically used in an FMS, and types of FMS layout. Functions of the Handling System. The material handling and storage system in an FMS performs the following functions: Random, independent movement of work parts between stations. This means that parts must be capable of moving from anyone machine in the system to any other machine.to provide various routing alternatives for the different parts and to make machine substitutions when certain stations are busy. Handle a variety of work part configurations. For prismatic parts, this is usually accomplished by using modular pallet fixtures in the handling system. The fixture is located on the top face of the pallet and is designed to accommodate different part configurations by means of common components, quick-change features, and other devices that permit a rapid build-up of the fixture for a given part. The base of the pallet is designed for the material handling system. For rotational parts, industrial robots are often used to load and unload the turning machines and to move parts between stations.

**Temporary storage.** The number of parts in the FMS will typically exceed the number of parts actually being processed at any moment. Thus, each station has a small queue of parts waiting to be processed. which helps to increase machine utilization.

- *Convenient access for loading and unloading work part.* The handling system must include locations for load/unload stations.
- *Compatible with computer control.* The handling system must be capable of being controlled directly by the computer system to direct it to the various workstations, load/unload stations, and storage areas. The primary handling system is sometimes supported by an automated storage system The FMS is integrated with an automated storage/retrieval system (AS/RS), and the S/R machine serves the work handling function for the workstations as well as delivering parts to and from the storage racks,

## 3. Computer Control System

The FMS includes a distributed computer system that is interfaced to the work stations, material handling system, and other hardware components. A typical FMS computer system consists of a central computer and microcomputers controlling the individual machines and other components. The central computer coordinates the activities of the components to achieve smooth overall operation of the system. Functions performed by the FMS computer control system can be grouped into the following categories:

1. Workstation control.
2. Distribution of control instructions to workstations.

## CAD/CAM/CIM

3. Production control.
4. Traffic control.
5. Shuttle control.
6. Work piece monitoring.
7. Tool control.
8. Performance monitoring and reporting.
9. Diagnostics.

### **4. Human Resources**

One additional component in the FMS is human labor. Humans are needed to manage the operations of the FMS. Functions typically performed by humans include:

- (1) Loading raw Work parts into the system,
- (2) Unloading finished parts (or assemblies) from the system.
- (3) Changing and setting tools.
- (4) Equipment maintenance and repair,
- (5) NC part programming in a machining system,
- (6) Programming and operating the computer system, and
- (7) Overall management of the system

### **4.10 FMS Layout Configurations**

FMS Layout Configurations. The material handling system establishes the FMS layout. Most layout configurations found in today's FMSs can be divided into five categories:

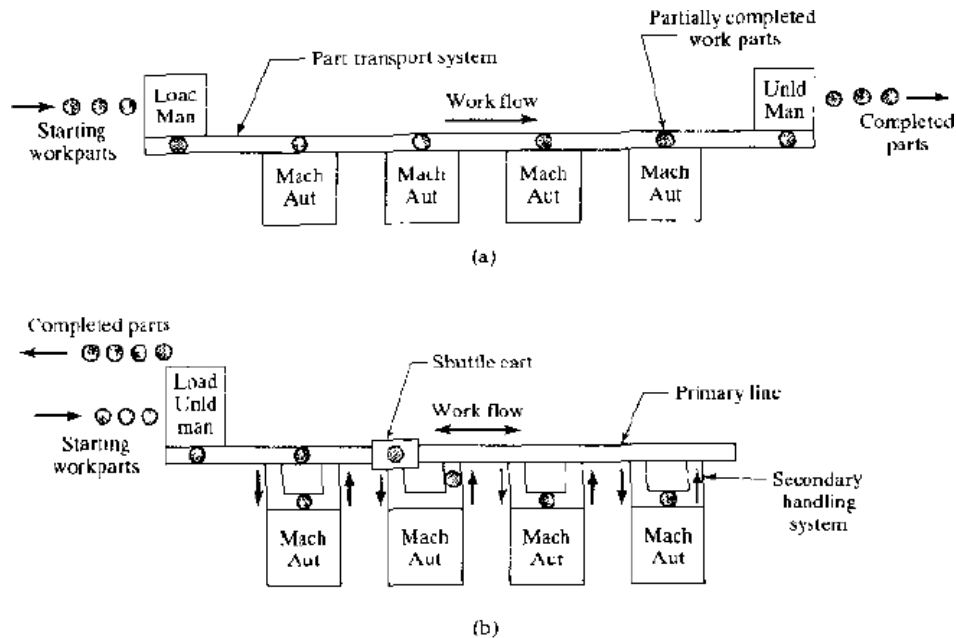
- (1) In-line layout,
- (2) Loop layout,
- (3) Ladder layout.
- (4) Open field layout, and
- (5) Robot-centered cell.

**TABLE 16.5** Material Handling Equipment Typically Used as the Primary Handling System for the Five FMS Layouts (*Chapter or Section Identified in Parentheses*)

<i>Layout Configuration</i>	<i>Typical Material Handling System (Chapter or Section)</i>
In-line layout	In-line transfer system (Section 18.1.2) Conveyor system (Section 10.4) Rail guided vehicle system (Section 10.3)
Loop layout	Conveyor system (Section 10.4) In-floor towline carts (Section 10.4)
Ladder layout	Conveyor system (Section 10.4) Automated guided vehicle system (Section 10.2) Rail guided vehicle system (Section 10.3)
Open field layout	Automated guided vehicle system (Section 10.2) In-floor towline carts (Section 10.4)
Robot-centered layout	Industrial robot (Chapter 7)

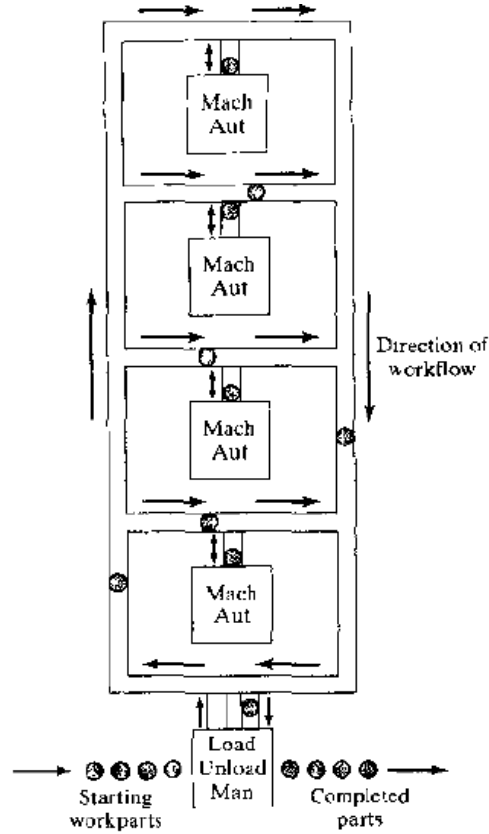
1. In the **in-line layout**, the machines and handling system are arranged in a straight line, as illustrated in Figure, 16.6 and 16.7. In its simplest form, the parts progress from one workstation to the next in a well-defined sequence, with work always moving in one direction and no back flow, as in Figure 16.7(a). The operation of this type of system is similar to a transfer line, except that a variety of work parts are processed in the system. Since all work units follow the same routing sequence, even though the processing varies at each station, this system is classified as type III A in our manufacturing systems classification system.

2. In the **loop layout**, the workstations are organized in a loop that is served by a part handling system in the same shape, as shown in Figure 16.8(a). Parts usually flow in one direction around the loop, with the capability to stop and be transferred to any stations. A secondary handling system is shown at each workstation to permit parts to move without obstruction around the loop. The load/unload stations are typically located at one end of the loop. An alternative form of loop layout is the rectangular layout. As shown in Figure 16.8(b), this arrangement might be used to return pallets to the starting position in a straight line machine arrangement.

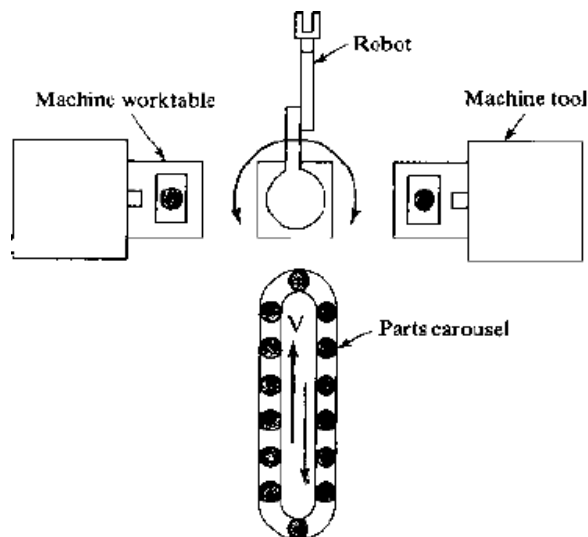


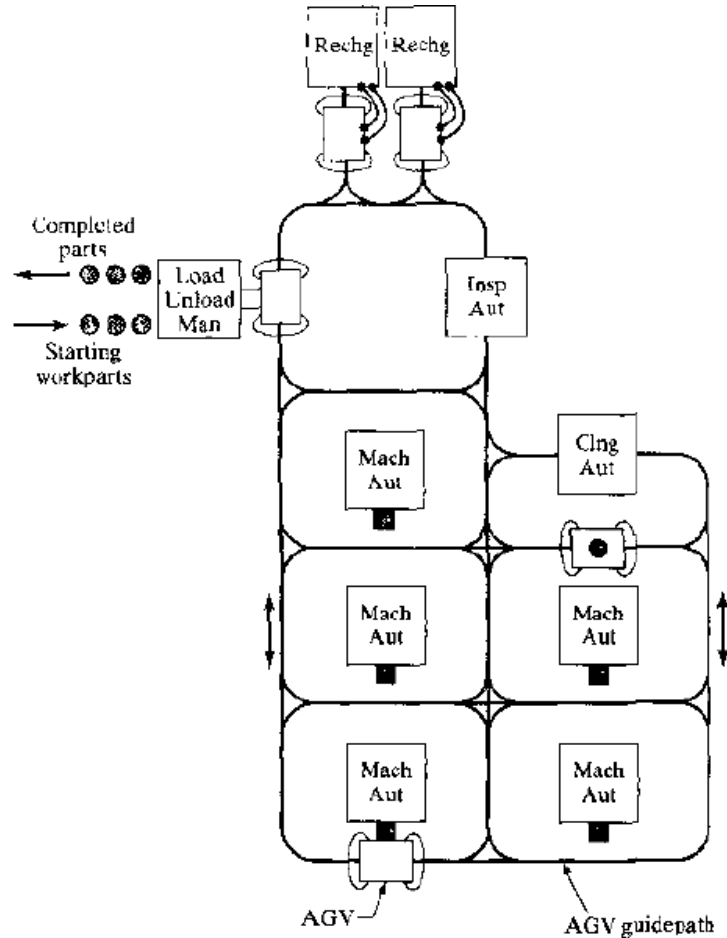
**Figure 16.7** In-line FMS layouts: (a) one direction flow similar to a transfer line and (b) linear transfer system with secondary part handling system at each station to facilitate flow in two directions. Key: Load = parts loading station, UnLd = parts unloading station, Mach = machining station, Man = manual station, Aut = automated station.

3. The **ladder layout** consists of a loop with rungs between the straight sections of the loop, on which workstations are located, as shown in Figure 16.9. The rungs increase the possible ways of getting from one machine to the next, and obviate the need for a secondary handling system. This reduces average travel distance and minimizes congestion in the handling system, thereby reducing transport time between workstations.
4. The **open field layout** consists of multiple loops and ladders and may include sidings as well, as illustrated in Figure 16.10. This layout type is generally appropriate for processing a large family of parts. The number of different machine types may be limited, and parts are routed to different workstations depending on which one becomes available first.
5. The **robot-centered cell** (Figure 16.1] uses one or more robots as the material handling system. Industrial robots can be equipped with grippers that make them well suited for the handling of rotational parts, and robot-centered FMS layouts are often used to process cylindrical or disk-shaped parts.



**Figure 16.9** FMS ladder layout. Key: Load = parts loading station, UnLd = parts unloading station, Mach = machining station, Man = manual station, Aut = automated station.





**Figure 16.10** Open field FMS layout. Key: Load = parts loading, UnLd = parts unloading, Mach = machining, Cng = cleaning, Insp = inspection, Man = manual, Aut = automated, AGV = automated guided vehicle. Rechg = battery recharging station for AGVs.

#### 4.11 FMS Benefits application

FMS Benefits application refer book (p.g no 480)

- A number of benefits can be expected in successful FMS applications. The principal benefits are the following:
- Increased machine utilization.
- Fewer machine required.
- Reduction in factory floor space required.
- Greater responsiveness to change.
- Reduced inventory requirements,
- Lower manufacturing lead times.

- Reduced direct labor requirements and higher labor productivity.
- Opportunity for unattended production.

#### 4.12 Automated Guided Vehicles

Automated guided vehicle systems (AGVs), commonly known as driverless vehicles, are turning out to be an important part of the automated manufacturing system. With the shift from mass production to mid-volume and mid-variety, flexible manufacturing systems, are increasingly in use. They require not only machine flexibility but also material handling, storage, and retrieval flexibility. Hence, the importance of AGVs has grown in manifold. It is a battery-powered driverless vehicle with programming capabilities for destination, path selection, and positioning. The AGVs belongs to a class of highly flexible, intelligent, and versatile material-handling systems used to transport materials from various loading locations to various unloading locations throughout the facility. The capability related to collision avoidance is nicely inbuilt in AGVS. Therefore, the vehicle comes to a dead stop before any damage is done to the personnel, materials, or structures. They are becoming an integral part of flexible manufacturing system installations. Now-a-days, AGVS are versatile in nature and possess flexible material-handling system. They use modern microprocessor technology to guide a vehicle along a prescribed path and makes correction if the vehicle strays from the path. A system controller receives instructions directly from the host computer, communicates with other vehicles, and issues appropriate commands to each vehicle. To avoid collision, communication is necessary among the AGVs. To facilitate the communication, they are connected through a wire in the floor or by radio.

1. Components of AGVS There are four main components of an automated guided vehicle system. They are as follows :

The Vehicle : It is used to move the material within the system without a human operator.

The Guide Path : It guides the vehicle to move along the path.

The Control Unit: It monitors and directs system operations including feedback on moves, inventory, and vehicles.

The Computer Interface : It is connected with other computers and systems such as mainframe host computer, the Automated Storage and Retrieval System (AS/RS), and the Flexible Manufacturing System.

Different Types of AGVS There are different types of automated guided vehicles that are able to cater different service requirements.

The vehicle types include :

- AGVS towing vehicles
- AGVS unit load transporters
- AGVS pallet trucks

- AGVS forklift trucks
- AGVS light-load transporters
- AGVS assembly line vehicles

The level of sophistication of the AGVS has increased to allow automatic positioning and pickup and drop-off (P/D) of cargo, and they also perform P/D services between machining work centers, storage racks, and the AS/RS. They are also capable of two-way Automated Material Handling travel on the same path and real-time dispatching under the control of the computer. The different types of AGVS are discussed in the section to follow.

**AGVS Towing Vehicle** AGVS towing vehicles were the earliest variety to be introduced. A towing vehicle is an automated guided tractor. A wide variety of tractors can be used, such as flatbed trailers, pallet trucks, custom trailers, and bin trailers. Different types of loading equipment used for loading and unloading the trailer include an AGV-pulled train, hand pallet truck, cranes, forklift truck, automatic transfer equipment, manual labor, shuttle transfer, and programmed automatic loading and unloading device.

**AGVS Pallet Trucks** AGVS pallet trucks are designed to lift, maneuver, and transport palletized loads. It is used for picking up or dropping off loads from and on to floor level, than removing the need for fixed load stands. No special accessories are needed for loading and unloading the AGVS pallet except that the loads should be on a pallet. It is basically used in floor-level loading and unloading operation. Loading and unloading can be done in two ways viz. automatically or manually. For the transportation of load, the normal course followed by the vehicle is determined by the storage area destination. Normal operations carried out in pallet trucks are : (i) loads are pulled off onto a spur, (ii) lowering of the pallet forks to the floor, (iii) pulling out from the pallet, and (iv) finally automatically returns empty to the loading area. **AGVS Forklift Trucks** An AGVS forklift truck has the capability to pick up and drop off palletized loads both at floor level and on stands, and the pickup height can be different from the drop-off height. They are capable of picking up and dropping off a palletized load automatically. It has the ability to position its forks at any height so that conveyors or load stands with different heights in the material-handling system can be serviced.

**AGVS forklift trucks** are one of the most expensive AGVS types. Therefore, they are used in the case of full automation. The truck is accoutered with sensors at the fork end, so that it can handle high-level stacking on its own. These systems have the advantage of greater flexibility in integrating with other subsystems with various loading and unloading heights throughout the material handling system.

**AGVS Light Load Transporters** They are applied in handling small, light parts over a moderate distance and distribute the parts between storage and number of work stations. **AGVS Assembly-Line Vehicles** AGVS assembly line vehicles are an acclimatization of the light-load transporters for applications involving serial assembly processes. The guided vehicle carries major sub-assemblies such as motors, transmissions, or even automobiles. As the vehicle moves from one station to the next, succeeding assembly operations are performed. After the loading of





Ans: jidoka and automation

3) Flexible manufacturing systems (FMS) are reported to have a number of benefits. Which is NOT a reported benefit of FMS?

- a) Increased quality
- b) Increase utilization
- c) Lead time and throughput time reduction
- d) More flexible than the manufacturing systems they replace

Ans: More flexible than the manufacturing systems they replace

4) The following is not a component of Automation system

- a) power
- b) program of instructions
- c) control system
- d) manpower

Ans: manpower

5) Which one does not stand for waste

- a) muda
- b) mura
- c) muri
- d) seri

Ans: seri

6) The authority to stop the production line is termed as

- a) kanban
- b) jidoka
- c) automation
- d) kaizen

Ans: jidoka

7) Kaizen stands for:

- a) continual improvement
- b) reducing inventory
- c) a card system
- d) none of the above

Ans: continual improvement

8) An approach that tries to match the output of manufacturing with market demand, in order to minimize inventories is called:

- a) MRP
- b) CAD
- c) JIT
- d) CAM

Ans:JIT

9) A computer-driven system for analyzing and projecting materials needs and then scheduling their arrival at the workstation at the right time is called:

- a) MRP
- b) CAD
- c) JIT
- d) CAM

Ans:MRP

10) \_\_\_\_\_ is a term developed by Philip B. Crosby for a performance standard that responds to the attitude in some organizations which assumes that mistakes are human.

- a) CAE
- b) Mass production
- c) Zero defects
- d) None of the above

Ans:Zero defects

11) Which of the following techniques would be used to manage a project such as the development and deployment of missiles?.

- a) Taylor chart
- b) Pert chart
- c) Walker chart
- d) All of the above

Ans:Pert chart

12) Basic just-in-time techniques do NOT include:

- a) Quality of working llife
- c) Line-stop authority

b) Market reaserch

d) Flexibility

Ans:Market reaserch

13) The basic practices underpinning just-in-time (JIT) do NOT include:

a) Creativity

c) Aotonomy

b) Development of staff

d) A 'them' and 'us' division of labour

Ans: A 'them' and 'us' division of labour

14) Just-in-time (JIT) does NOT include which one of the following?

a) High inventory production

c) Lean manufacturing

b) Batch sizes of one

d) Fast through-put manufacturing

Ans: High inventory production

### 2MARKS

1) Identify different kinds of wastes in Lean production.

- a. Transportation
- b. Inventory
- c. Material handling
- d. Waiting
- e. Over production
- f. Over processing
- g. Defects

2) Define AGVS.

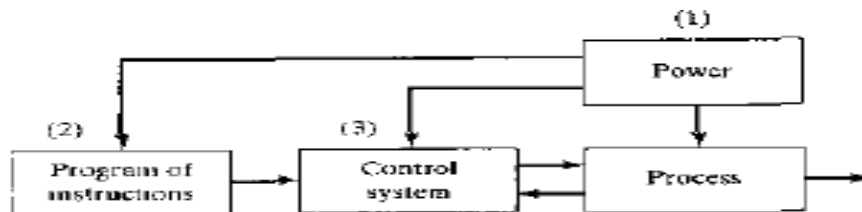
AGVS: - Automated Guided Vehicle System- These are battery powered automatically steered vehicles that follow defined pathways in the floor

3) List out different types of storage systems

- Bulk storage
- Rack system
- Shelving and Bins
- Drawer storage
- Automated storage system

4) Outline the major objectives of CIM.

- To meet Competitive pressures.
  - To coordinate and organize data.
  - To eliminate paper and cost associated with its use.
  - To automate communication within a factory
  - To facilitate simultaneous engineering.
- 5) Discuss about the advantages of communication networking.
- More efficient Management of Resources
  - Networks help keep information reliable and up-to-date.
  - Network help speed up data sharing
  - Network help in business service their clients more effectively.
  - Networks greatly expand a business marketing and customer service capability.
- 6) What are the main elements of an automated system



**Figure 3.2** Elements of an automated system: (1) power, (2) program of instructions, and (3) control systems.

- 7) List out different types of FMS layouts
- in-line layout,
  - loop layout,
  - Ladder layout.
  - open field layout,
  - Robot-centered cell.

## Important Big Questions

To access hyper link click (ctrl + mouse click )

Mechanical Engineering

ME403 – CAD/CAM/CIM  
 IMPORTANT QUESTIONS

1. Explain briefly about the basic elements and levels of automation
2. Define Flexible Manufacturing System. & Explain briefly about the components of Flexible Manufacturing System
3. Explain the various types of FMS
4. List out the different types of FMS layouts with proper explanations and suitable sketches. Discuss about the application and benefits of FMS
5. Explain the objectives and various concepts of Lean production.
6. Describe the elements of Just in Time Production
7. Differentiate between push vs. pull manufacturing system with suitable sketches
8. Identify different kinds of wastes in Lean production.
9. Define AGVs and AS/RS. and its types.
10. Enumerate the Difference between FMS and FMC.
11. List out different types storage systems.
12. Explain the kanban system.

UNIT-V	COMPUTER INTEGRATED MANUFACTURING SYSTEMS	9
Evolution of CAD/CAM and CIM - Integration of CNC machines in CIM environment, Definition- CIM Wheel- -CIM concepts – Computerized elements of CIM system –Types of production Communication fundamentals- local area networks -topology -LAN implementations - network management and installations - networking concepts,		

## UNIT-V COMPUTER INTEGRATED MANUFACTURING SYSTEMS

### WHAT IS CIM?

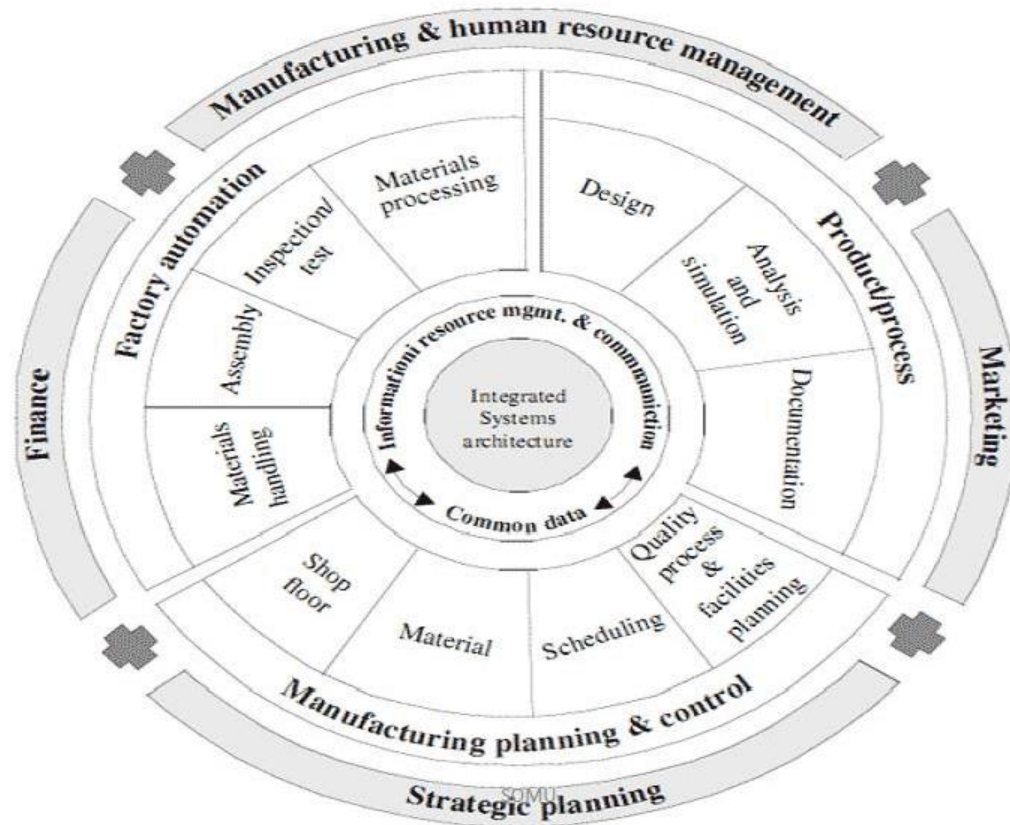
- The term CIM comprises three words – computer, integrated and manufacturing. CIM is the application of computers in manufacturing in an integrated way.
- CIM is an attempt to combine computer technologies in order to manage and control the entire business and manufacturing.
- CIM is the computerization of design, manufacturing, distribution and financial/business function into one coherent system.

### DEFINITION OF CIM (CASA/SME)

- CIM is the integration of the total manufacturing enterprise through the use of integrated systems and data communications coupled with new managerial philosophies that improve organizational and personnel efficiency.

### CASA/SME's CIM wheel

# CASA/SME's CIM wheel



## Historical review of CIM

- 1909 – Ford's concepts of Production lines were used
- 1923 – Automatic transfer lines were introduced.
- 1952 – Generation of punched paper tapes
- 1954 – First NC Milling machine used.
- 1959 – application of control using digital computer
- 1960 – First NC Control Unimate Robot was installed.
- 1963 – Sketchpad usage
- 1965 – International business machines developed.
- 1973 – CNC – DNC Concepts developed
- 1980 - Concept of FMS established.



### WHY CIM ?

- To meet Competitive pressures.
- To coordinate and Organize data.
- To eliminate paper and cost associated with its use.
- To automate communication within a factory
- To facilitate simultaneous engineering.

### Objectives of CIM

The main aim of CIM is to use the advanced information processing technology into all areas of manufacturing industry

- More productive and efficient
- Increase product reliability
- Decrease the cost of production and maintenance
- Reduces the number of hazardous jobs

### CIM I VS CIM II

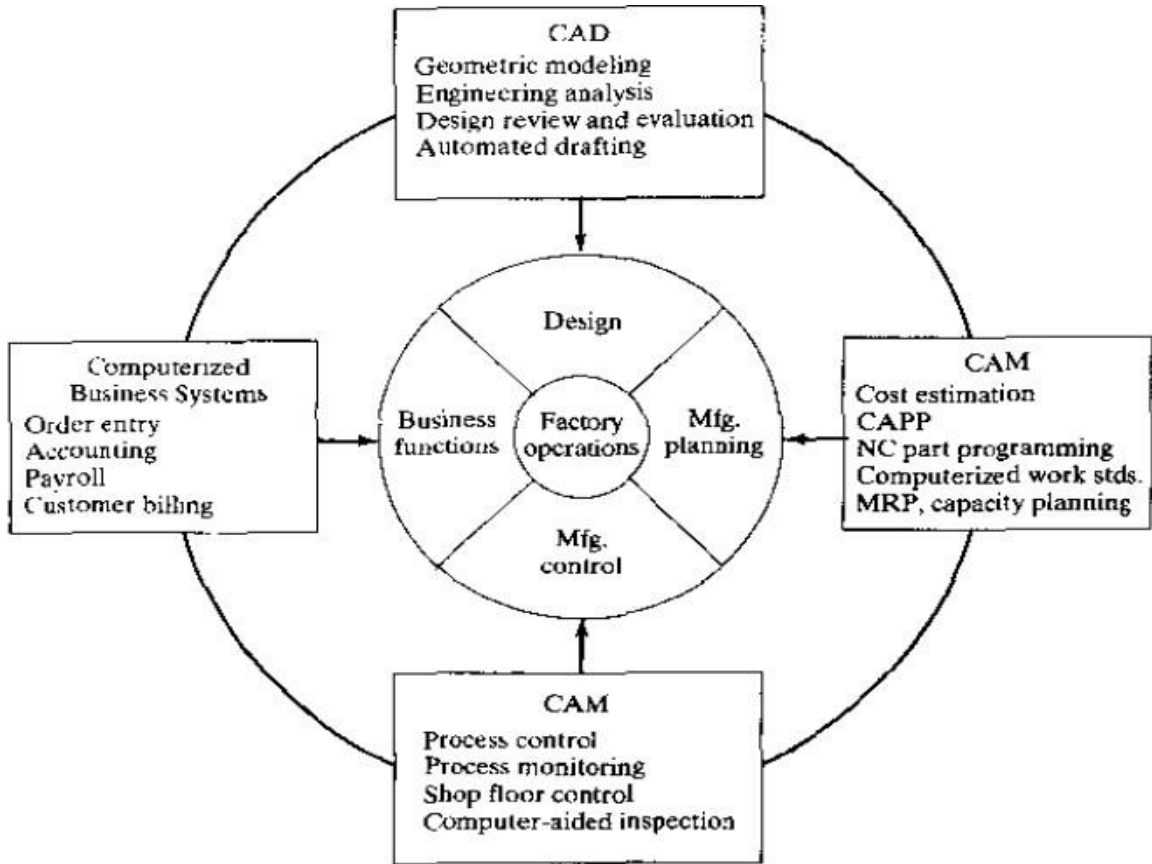
#### CIM I – COMPUTER INTERFACED MANUFACTURING

- aimed at interfacing the existing systems
- result of the fourth generation of computers (data interfacing)

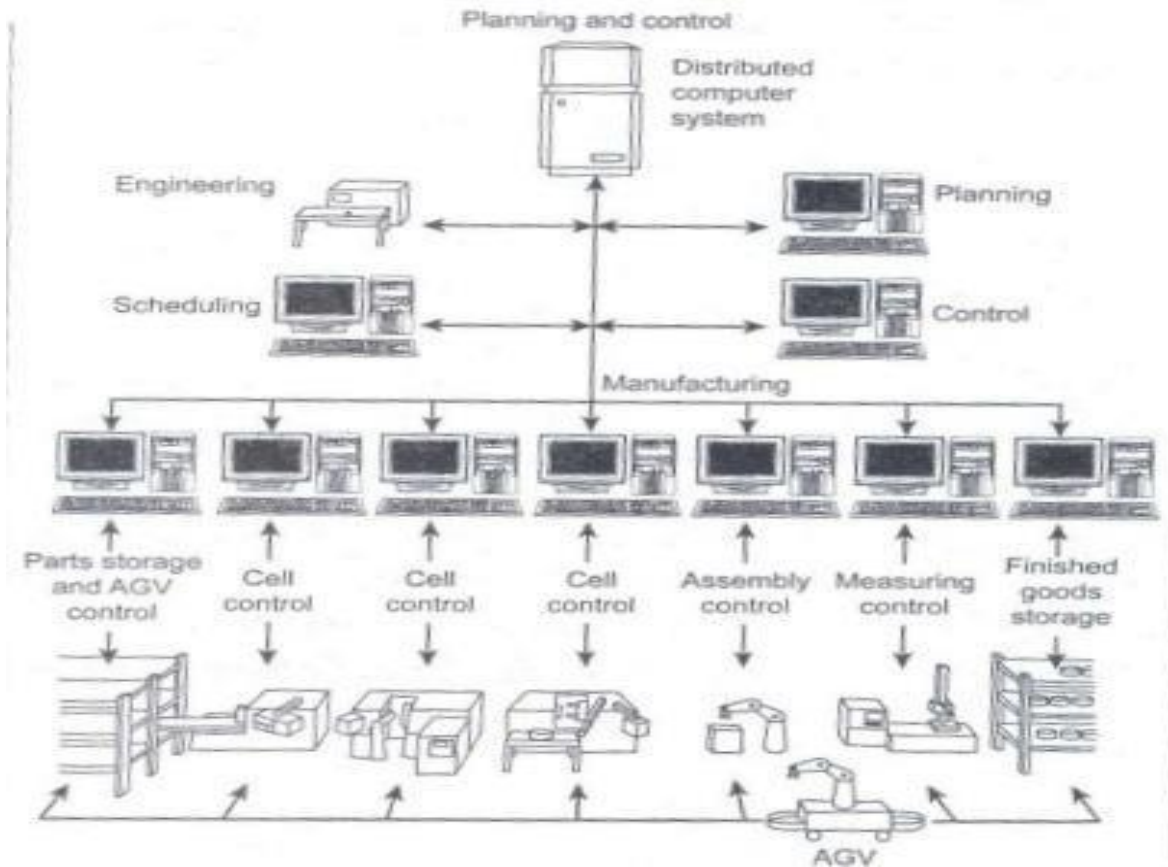
#### CIM II – COMPUTER INTEGRATED MANUFACTURING

- The integration of total manufacturing enterprises through the use of integrated systems and data communications
- result of the fifth generation of computers (networking)
- finally, CIM II is a true CIM which means at true integration of systems

### Computerized Elements of CIM system

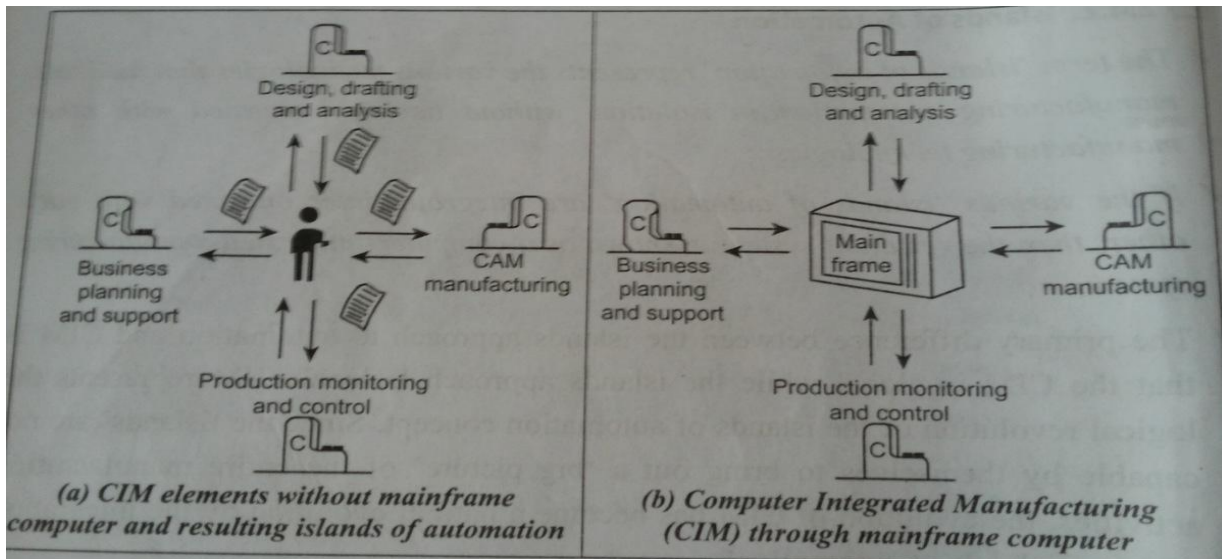


Schematic diagram of CIM



Islands of automation

Islands of Automation represents the various technologies that facilitates manufacturing automation in isolation, without having integrated with other manufacturing technologies.





## **CIM SOFTWARE**

- **Design Program**
- **DBMS Program**
- **MIS Program**
- **Analysis Program**
- **Monitoring Program**
- **Bar Code Program**
- **Conveyor Program**
- **Job Tracking Program**
- **Simulation program**
- **Communications program**
- **Production control program**
- **Marketing program**

### **Potentials Benefits of CIM**

#### **TANGIBLE BENEFITS**

Higher Profits, Improved Quality, Lower Cost, Reduced Scrap and Rework, Increased Factory Capacity, Shorter Lead Time, Improved Performance, Reduced Inventory, Increased Manufacturing Productivity, Increased machine utilization, Etc.

#### **INTANGIBLE BENEFITS**

Customer Service, Greater Flexibility, Greater Responsiveness, Improved Competitiveness, Safer Working Environment, Higher Employee Morale, More opportunities for upgrading skills Etc..

### **Facilities Layout Design and Facilities Location**

- Facilities layout design refers to the arrangement of all equipment, machinery, and furnishings within a building envelope after considering the various objectives of the facility. The layout consists of production areas, support areas, and the personnel areas in the building (( Tompkins, J. A., et al., *Facility Planning*, Second Edition , John Wiley & Sons, NY,1996 )

### **Need of Facilities Layout Design**

- The need for facilities layout design arises both in the process of designing a new layout and in redesigning an existing layout.

- The need in the former case is obvious but in the latter case it is because of many developments as well as many problems with in the facility such as change in the product design, obsolescence of existing facilities, change in demand, frequent accidents, more scrap and rework, market shift, introduction of a new product etc.

### **Objectives of Facilities Layout Design**

Primary objectives of a typical facility layout include

- (1) Overall integration and effective use of man, machine, material, and supporting services,
- (2) Minimization of material handling cost by suitably placing the facilities in the best possible way,
- (3) Better supervision and control,
- (4) Employee's convenience, safety, improved morale and better working environment,
- (5) Higher flexibility and adaptability to changing conditions and
- (6) Waste minimization and higher productivity.

### **Types of Layout**

Basic types of layouts are:

- 1.Product layout
- 2.Process layout
- 3.Fixed position layout
- 4.Cellular layout

### **Product layout**

This type of layout is generally used in systems where a product has to be manufactured or assembled in large quantities. In product layout the machinery and auxiliary services are located according to the processing sequence of the product without any buffer storage within the line itself. A pictorial representation of a product type of layout is given in Figure 1. The advantages and disadvantages are given in Table 1.

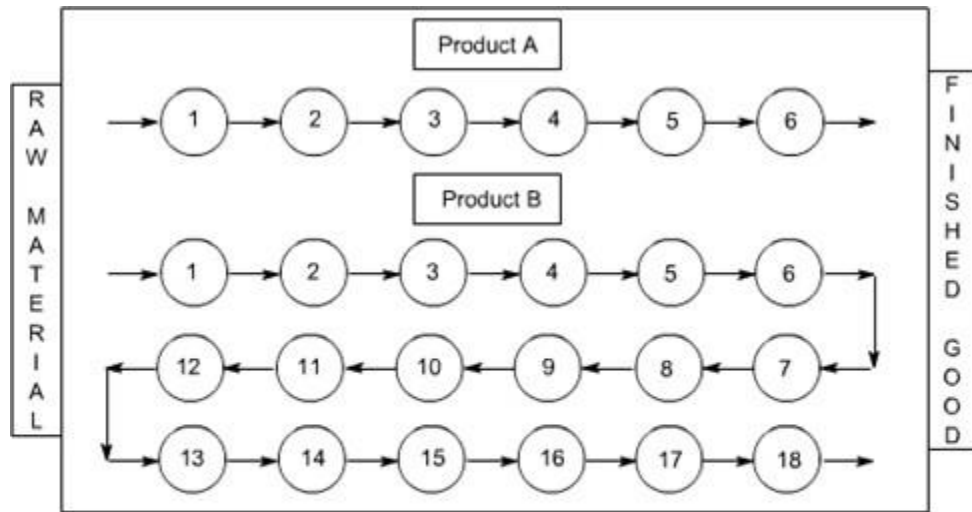


Figure 1: A Pictorial Representation of Product Type of Layout

• **Table 1: Advantages And Disadvantages of Product Type of Layout**

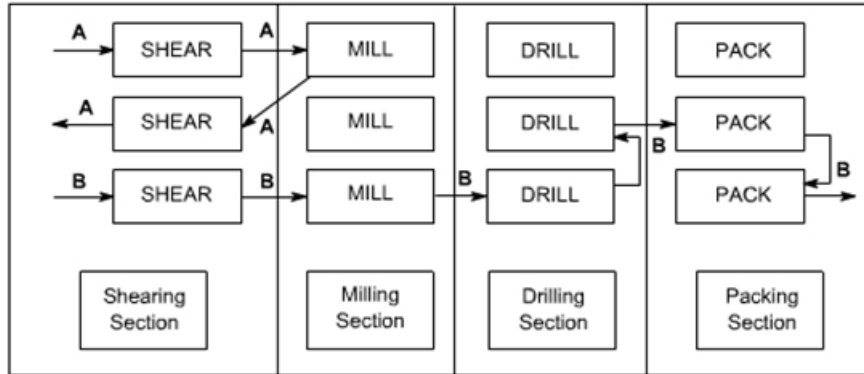
ADVANTAGES	DISADVANTAGES
<ul style="list-style-type: none"> <li>• Low material handling cost per unit</li> <li>• Less work in process</li> <li>• Total production time per unit is short</li> <li>• Low unit cost due to high volume</li> <li>• Less skill is required for personnel</li> <li>• Smooth, simple, logical, and direct flow</li> <li>• Inspection can be reduced</li> <li>• Delays are reduced</li> <li>• Effective supervision and control</li> </ul>	<ul style="list-style-type: none"> <li>• Machine stoppage stops the line</li> <li>• Product design change or process change causes the layout to become obsolete</li> <li>• Slowest station paces the line</li> <li>• Higher equipment investment usually results</li> <li>• Less machine utilization</li> <li>• Less flexible</li> </ul>



**PROCESS LAYOUT**

**Process layout**

- In a process layout, (also referred to as a job shop layout) similar machines and services are located together. Therefore, in a process type of layout all drills are located in one area of the layout and all milling machines are located in another area. A manufacturing example of a process layout is a machine shop. Process layouts are also quite common in non-manufacturing environments. Examples include hospitals, colleges, banks, auto repair shops, and public libraries
- A pictorial representation of a process type of layout is given in Figure 2. The advantages and disadvantages are given in Table 2.



**Figure 2: A Pictorial Representation of Process Type of Layout**

**Table 2: Advantages And Disadvantages of Process Type of Layout**

ADVANTAGES	DISADVANTAGES
<ul style="list-style-type: none"> <li>•Better machine utilization</li> <li>•Highly flexible in allocating personnel and equipment because general purpose machines are used.</li> <li>•Diversity of tasks for personnel</li> <li>•Greater incentives to individual worker</li> <li>•Change in Product design and process design can be incorporated easily</li> <li>•More continuity of production in unforeseen conditions like breakdown, shortages, absenteeism</li> </ul>	<ul style="list-style-type: none"> <li>•Increased material handling</li> <li>•Increased work in process</li> <li>•Longer production lines</li> <li>•Critical delays can occur if the part obtained from previous operation is faulty</li> <li>•Routing and scheduling pose continual challenges</li> </ul>



• **Fixed location layout**

• In this type of layout, the product is kept at a fixed position and all other material; components, tools, machines, workers, etc. are brought and arranged around it. Then assembly or fabrication is carried out. The layout of the fixed material location department involves the sequencing and placement of workstations around the material or product. It is used in aircraft assembly, shipbuilding, and most construction projects. A pictorial representation of a fixed location type of layout is given in Figure 3. The advantages and disadvantages are detailed in Table 3.

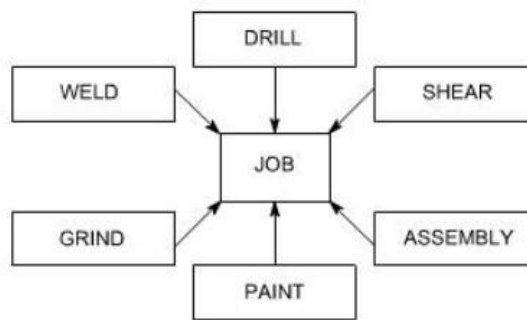


Figure 3: A Pictorial Representation of Fixed Location Type of Layout

Table 3: Advantages And Disadvantages of Fixed Location Type of Layout

ADVANTAGES	DISADVANTAGES
<ul style="list-style-type: none"> <li>•Material movement is reduced</li> <li>•Promotes pride and quality because an individual can complete the whole job</li> <li>• Highly flexible; can accommodate changes in product design, product mix, and production volume</li> </ul>	<ul style="list-style-type: none"> <li>•May result in increase space and greater work in process</li> <li>•Requires greater skill for personnel</li> <li>•Personnel and equipment movement is increased</li> <li>•Requires close control and coordination in production and personnel scheduling</li> </ul>

SOMU

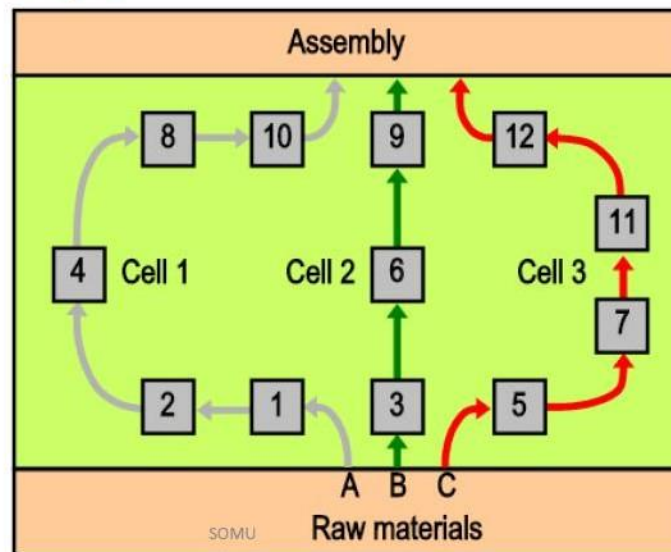
### Cellular manufacturing layout

- In cellular manufacturing, production work stations and equipment are arranged in a sequence that supports a smooth flow of materials and components through the production process with **Minimal Transport or Delay**.
- Implementation of this Lean Method often represents an attempt to combine the flexibility of a process layout with the efficiency of a product layout
- Rather than processing multiple parts before sending them on to the next machine or process step (as is the case in **batch-and-queue, or large-lot production**), cellular manufacturing aims to move products through the manufacturing process **one-piece at a time, at a rate determined by customers' needs**.
- The approach seeks to minimize the time it takes for a single product to flow through the entire production process.

## Types of Layout

### Group Technology/Cellular Layout – Example A (page 4)

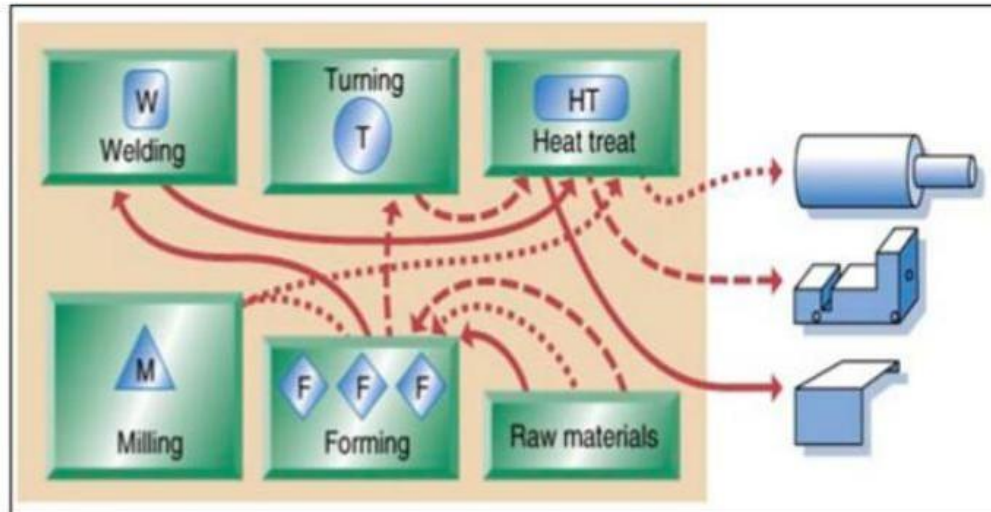
#### Revised Cellular Layout



## Types of Layout

### Group Technology/Cellular Layout – Example B (page 2)

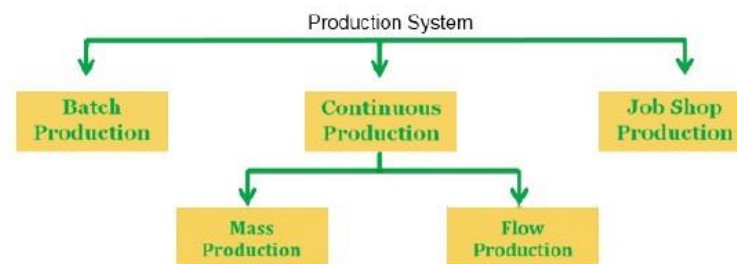
Process Flows before the Use of GT Cells



## What is meant by production systems?

- Theoretically, production systems are transformation processes, which transform a given amount of resources (inputs) into goods and services (finished output) that are useful to mankind. The "Five Ms", known to be the most basic requirements that effect a transformation, are men, machines, methods, material and money. In economics , these factors of production are recognized as labor, capital and land.

There are three types of production systems:



**Batch Production** involves the manufacturing of a number of identical products to satisfy a demand or meet a specific order. When the production by a plant and its equipment is terminated, the plant and equipment can be used for producing similar kind of products. This system can also be divided into three categories:

A batch produced only once: Here, customers place an order with a firm and they mention their specifications. The size of the order is greater than that of the **job shop** production order. The firm has to plan for the resources after taking the order from the customer.

- A batch produced at irregular intervals as per customer order or when the need arises: As the frequency is irregular, a firm can maintain a file of its detailed plans and it can go through its **Shop Productions** previous files and start the production.
- A Batch Produced periodically at known Intervals: Here, a firm either receives an order from a customer at regular intervals or it may produce a product to satisfy the demand of its customer. It can have a well-designed file of its plans, material requirement and instructions for quick reference. It can also purchase the material required in bulk in advance. As the frequency of regular orders goes on increasing, the Batch Production system transforms into Mass Production System. Here also, in case the demand for a particular product ceases, the plant and machinery can be used for producing other products and there will be slight modifications in the layout or in the machinery and equipment themselves.
- The examples of companies associated with Batch Production include Tyre Production Shops, Readymade dress companies, Cosmetic manufacturing companies etc.



### Continuous Production

- Continuous Production system involves specialized manufacturing of identical products, which require their machinery and equipment to work dedicatedly on them. Continuous production is normally associated with large quantities and a high demand. Hence, a manufacturer tries to reap the benefits of automatic production. This system is categorized into:

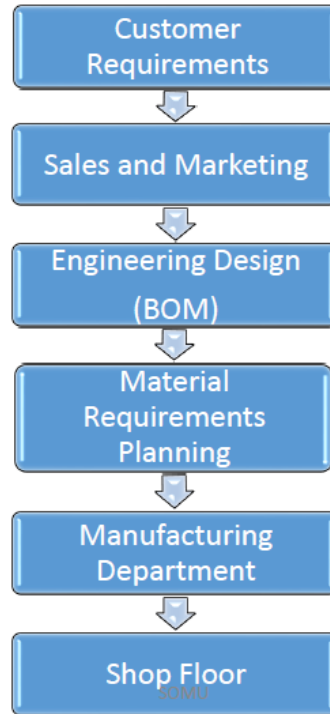
This system is classified categorized into:

- **Mass Production:** Here, the same type of product is produced to meet the demand of the market or an assembly line or the market. This system needs good planning for as far as material, process, maintenance of machines and instructions to operators are concerned. In the case of Mass Production, purchasing different materials in bulk quantities is advisable. The components of industrial products serve as examples of Mass Production.
- **Flow Production:** The difference between Mass Production and Flow Production lies in their respective product types and the relation of the products with their is the type of product and its relation to the respective plants. In Mass Production, identical products are produced in large numbers. If their demand falls or ceases, the machinery and equipment can be modified slightly, after slight modification be and used for manufacturing similar kind of products. In Flow Production, the plant and its equipment are used for manufacturing specific products. Hence Therefore, if the demand falls for a product falls or ceases, the plant cannot be used for manufacturing other products. It is scraped. The plants associated with Flow Production include **cement factories, sugar factories, oil refineries etc.**

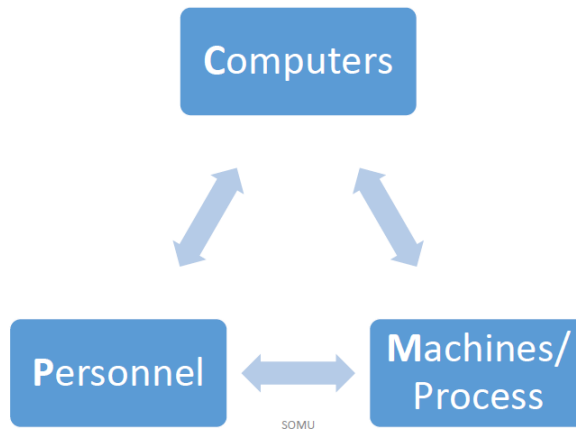
### Job Shop Production

- In this system, products are manufactured to meet the requirements of a specific order. Quality is not given too much importance and the manufacturing of a product takes place as per the specifications given by the customer. This system may be further classified into the following categories:
- **The Job produced only once:** Here, a customer visits a firm and places their order. When the product is ready, the customer takes it and leaves. The customer may not visit the firm again to place an order for the same product. Such a firm will have little scope for pre-planning the production of a product. The norm will be that it will plan for the materials, manpower and the process to be followed only after it has received an order from a customer.
- **The job produced at irregular intervals:** Here, a customer visits a firm to place orders for the same type of the product at irregular intervals. The firm will not have any idea of the customer's visits. Here as well, the planning for materials, manpower and the process to be followed will start only after a customer has placed their order. In case the firm maintains a record of the Jobs Produced by it, it can refer to its previous plans when a customer arrives at its door to place a new order.

# Network communications



## Families of Communications matrix in CIM

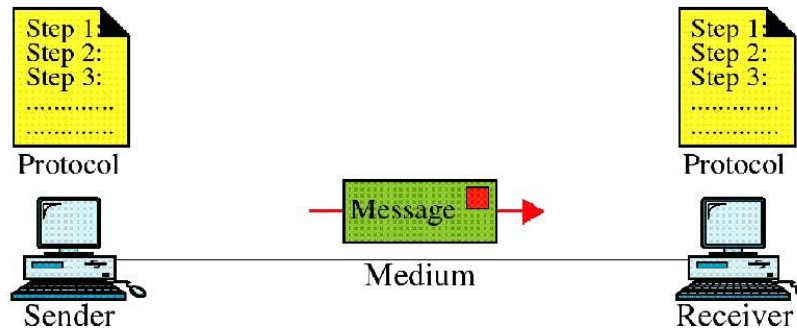


## Communication matrix

	P	C	M
P (Personnel)	P - P	P - C	P - M
C (Computer)	C - P	C - C	C - M
M (Machine)	M - P	M - C	M - M

## Data communications and components

Data communication is the exchange of data between two devices via some form of transmission medium



## NETWORKS

A communication network is a collection of equipment and physical media that interconnects two or more communication devices

### ADVANTAGES OF NETWORKS

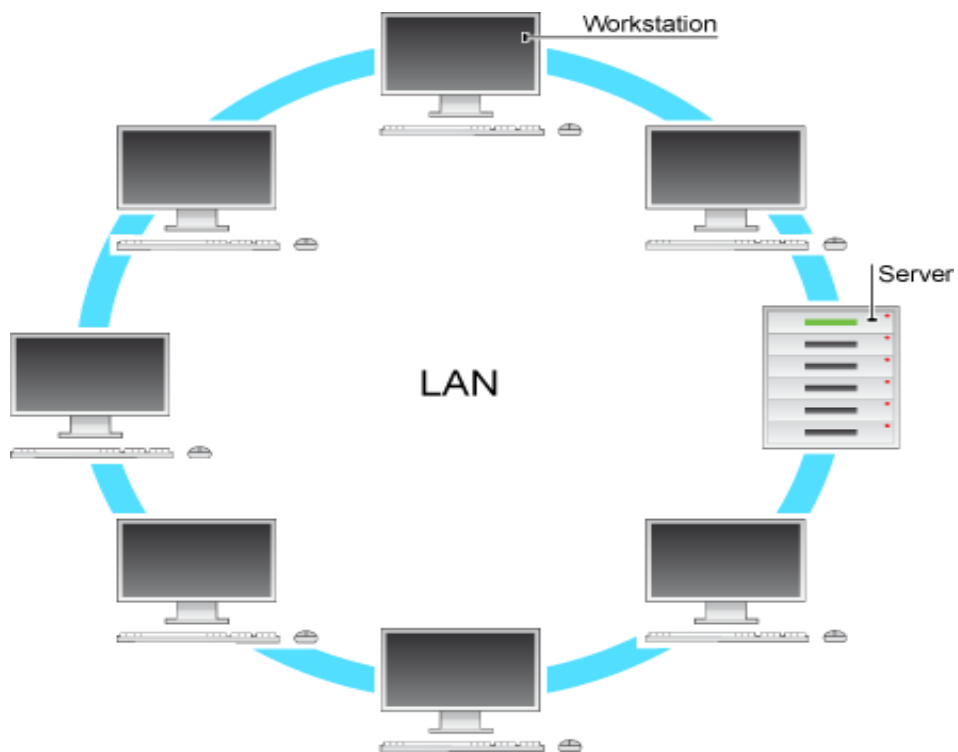
- More efficient Management of Resources
- Networks help keep information reliable and up-to-date.
- Network help speed up data sharing
- Network help in business service their clients more effectively.
- Networks greatly expand a business marketing and customer service capability.

## TYPES OF NETWORKS

1. Local Area Networks (LANs)
  - Client/Server
  - Peer to Peer
2. Metropolitan Area Networks (MANs)
3. Wide Area Networks (WANs)

### Local area networks

- ❖ LAN is privately owned communications network that serves users with in a confined geographical area (example office, a group of building close together, and college campus ).
- ❖ Now days, LAN have data rates reached 100 Mbps with GB systems
- ❖ Realize large productivity and cost savings to organizations





# Types of LAN

## 1. Client/server

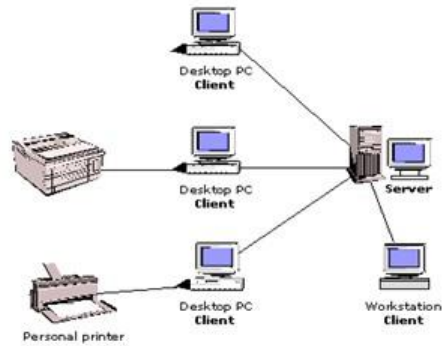
Requesting microcomputers called client

Supplying devices called servers

One or more administrator can manage security

and permission, convenient backup,

reduces network traffic



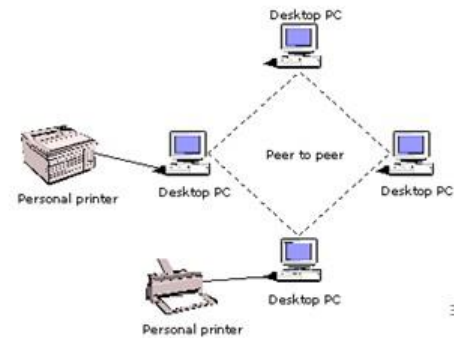
## 2. Peer-to-Peer

All microcomputers on the network communicate

Directly with one another without relying on a server

Every computer act as both client & server

Security is not an issue

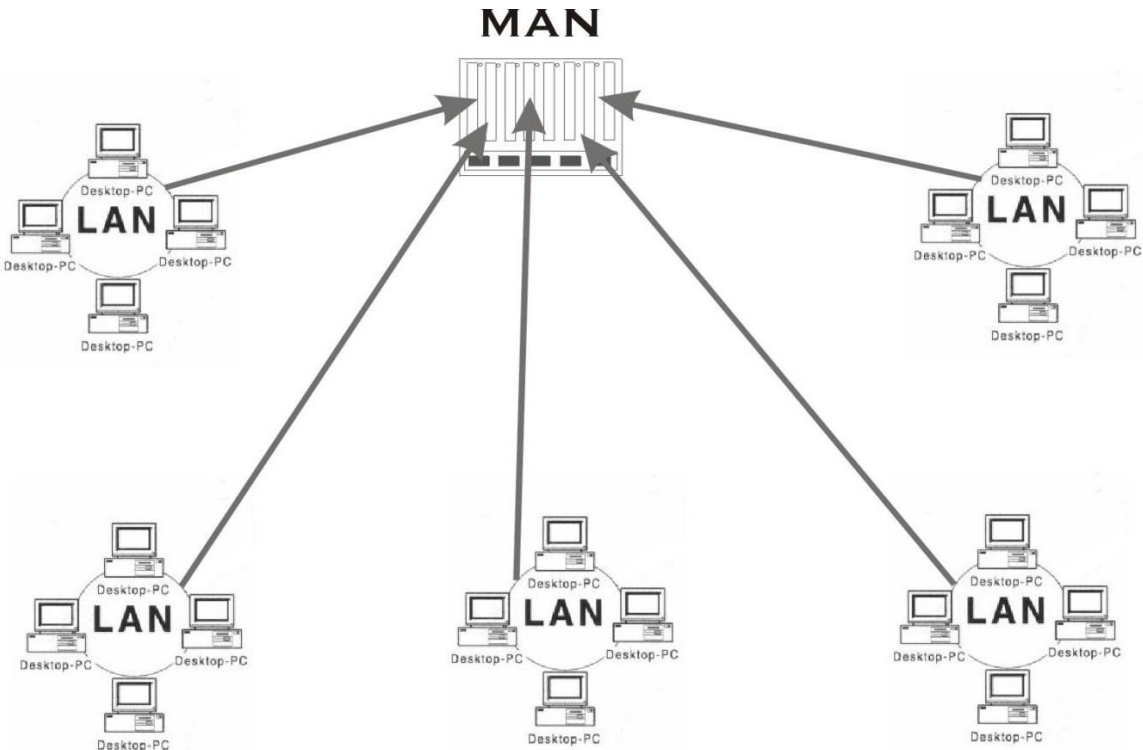


SOMU

32

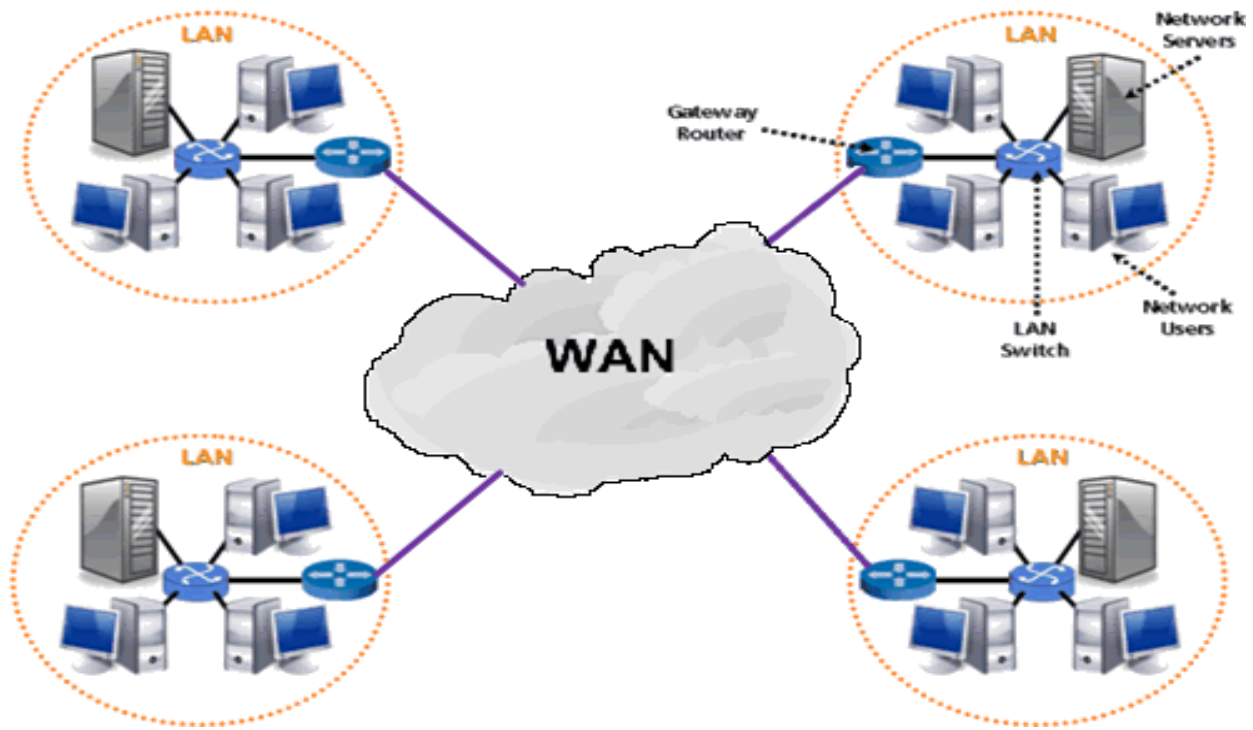
## Metropolitan area networks (MANS)

- Communications network covering a geographic area the size of a city



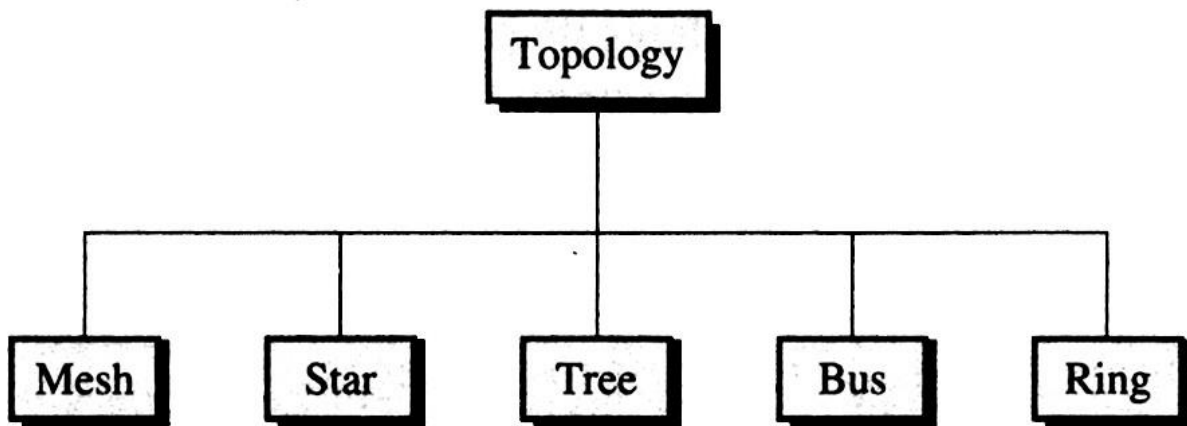
### Wide area networks (WANs)

WAN it provides long-distance transmission of data over large geographical areas that may comprise the whole world.



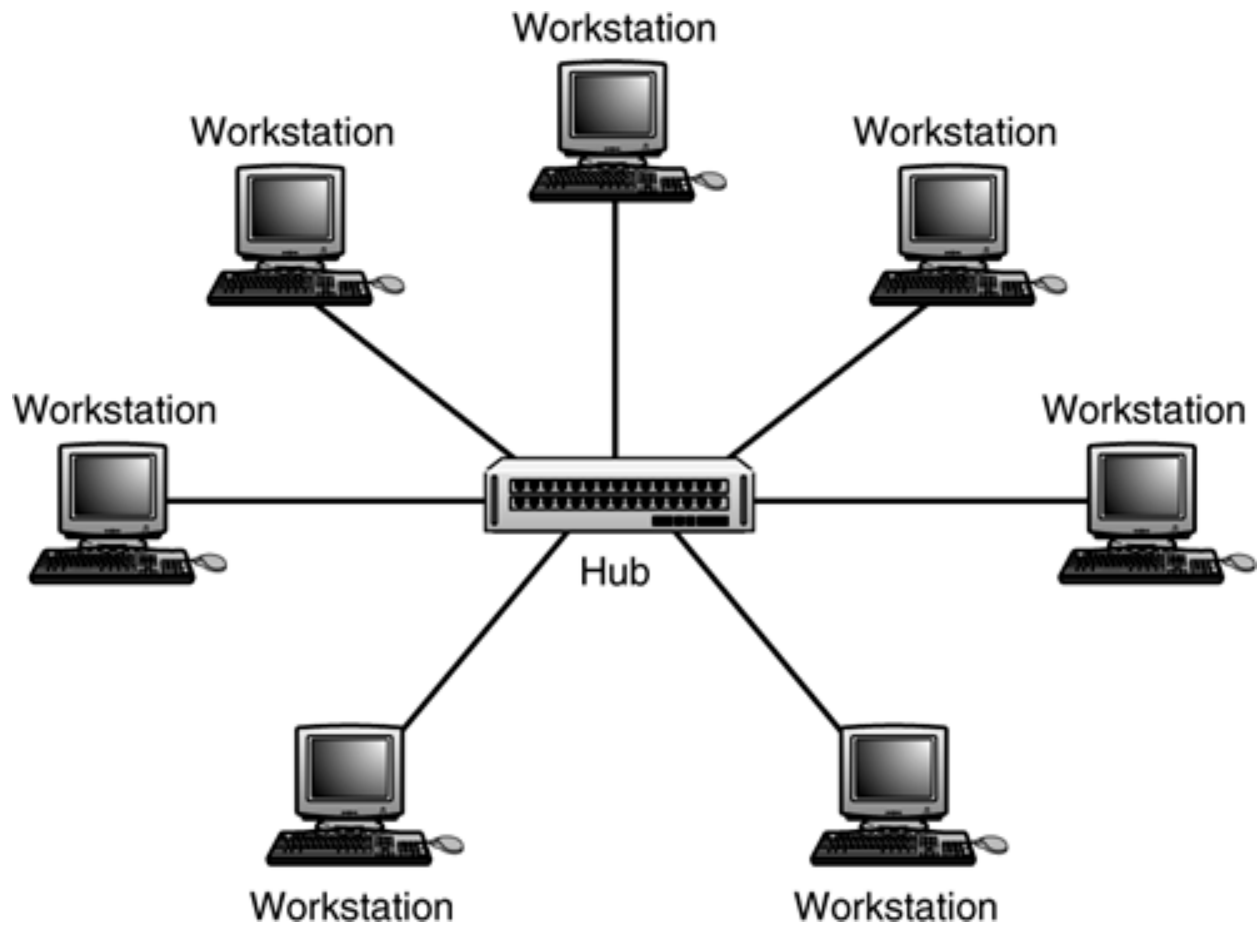
### Network topology (types of communication line)

The geometric representation of the relationship of all the links and linking devices to each other.



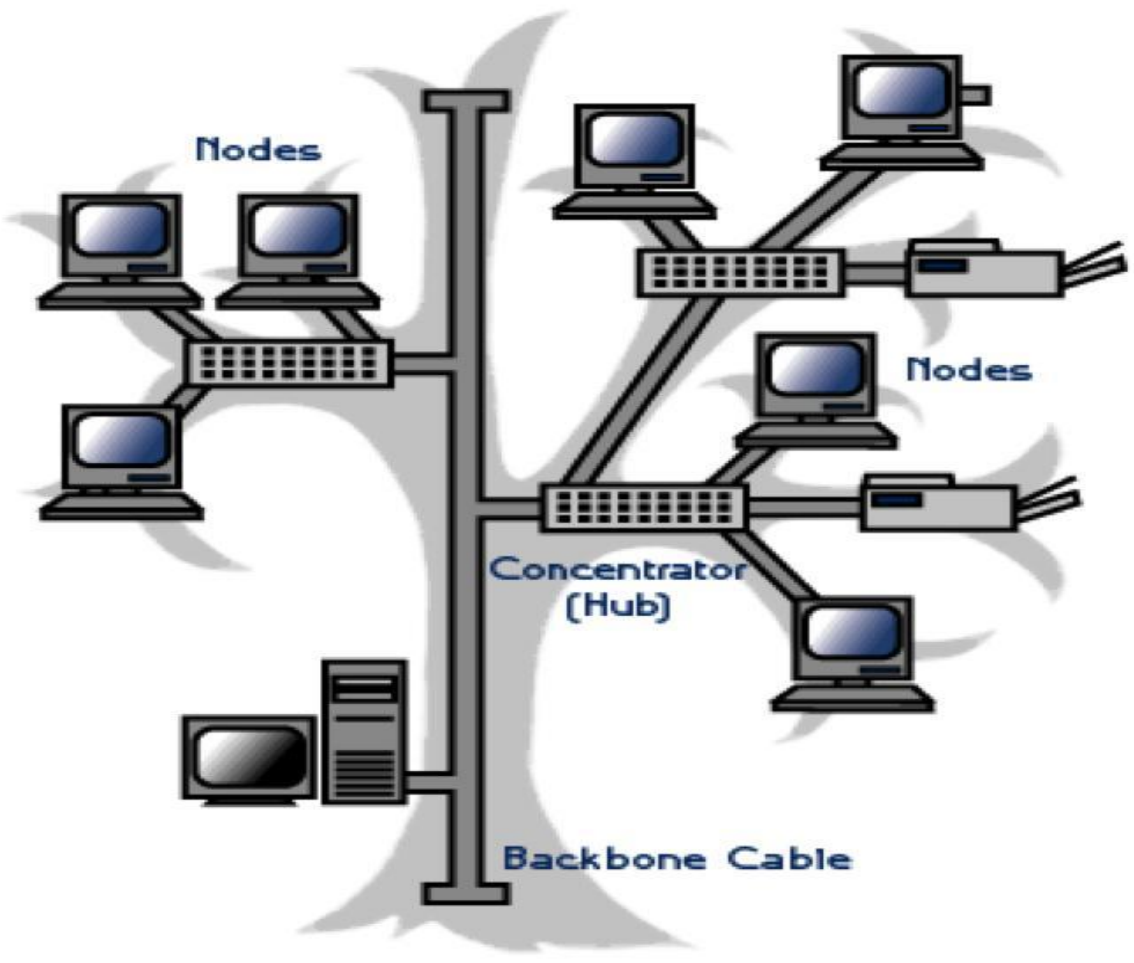
### STAR (or) RADIAL TOPOLOGY

- Each devices has a dedicated point-to-point link only to a central controller as a HUB it is also called as point-to-point (PTP) connection



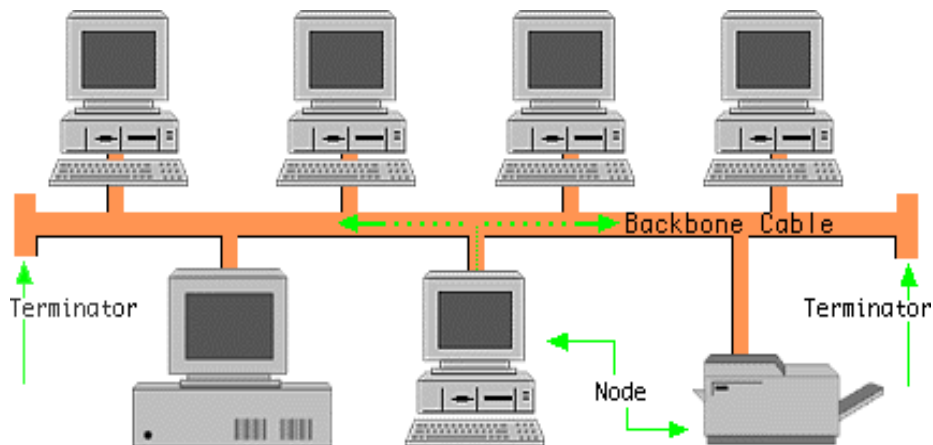
**TREE TOPOLOGY**

- The majority of devices connect to a secondary hub that in turn is connected to the central hub



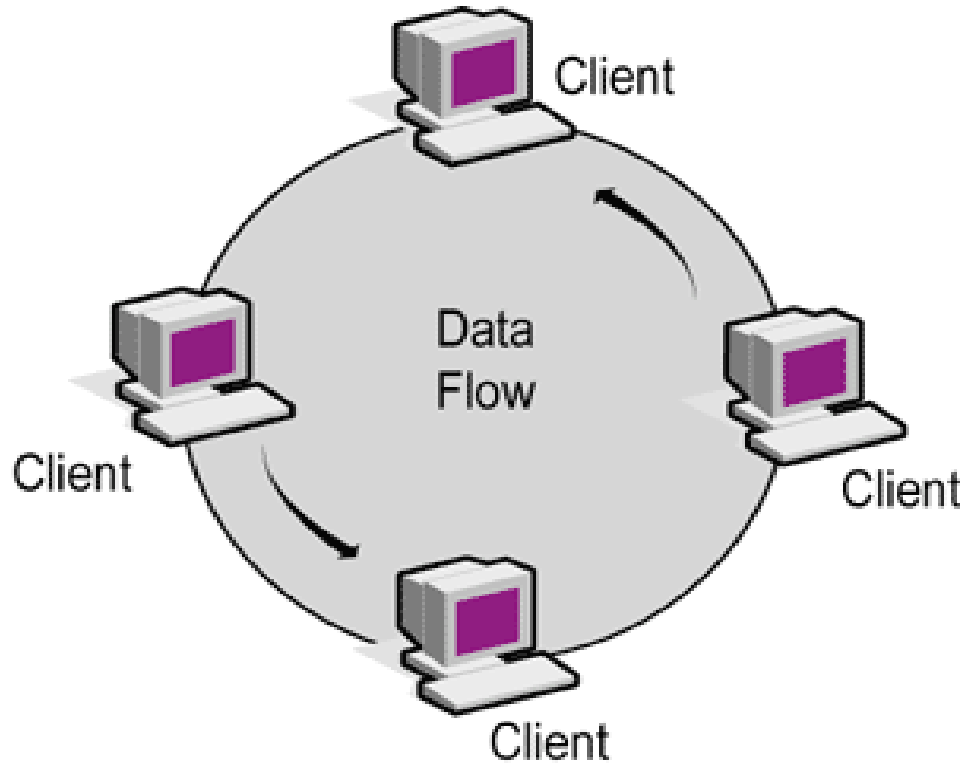
### BUS TOPOLOGY

- Nodes are connected to the bus cable by drop lines and taps. Drop line is a connection running between the device and the main cable. Tap is a connector

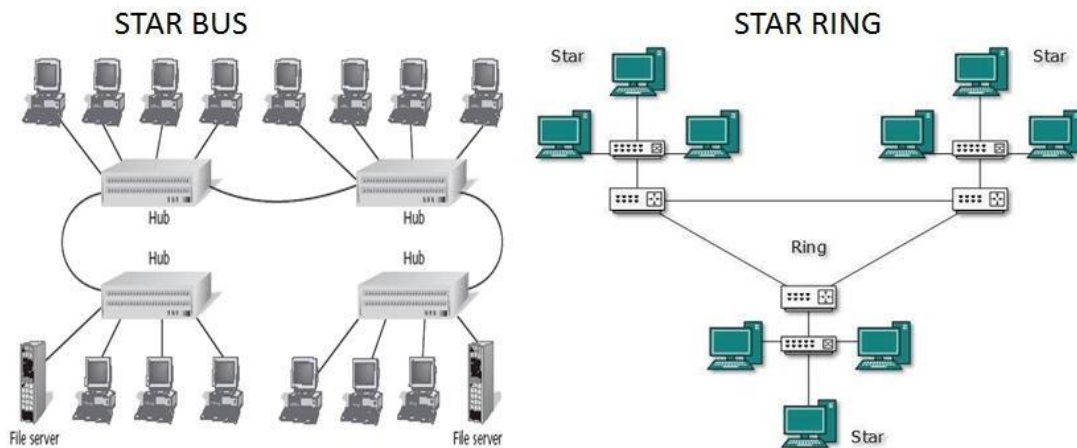


## RING TOPOLOGY

- Each device is connected to two and only to neighboring devices.



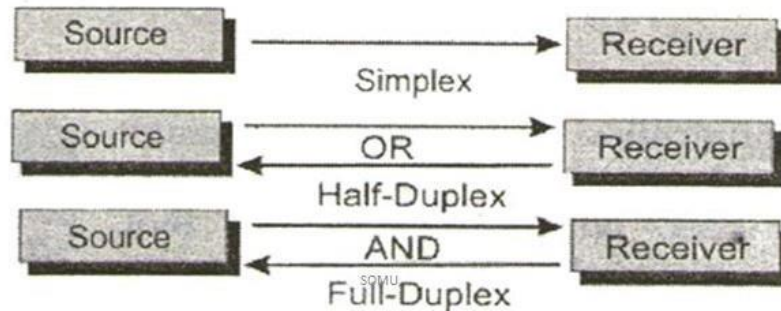
## HYBRID TOPOLOGIES



## DATA FLOW(TRANSMISSION MODE)

- Transmission modes refers to the direction of information flow between two devices. There are three types of transmission modes,

- Simplex Transmission
- Half – duplex Transmission
- Full – duplex Transmission



41

### COMPONENTS OF LAN

- Connection or Cabling Systems.
- Microcomputer with interface cards
- Network operating system
- Repeaters
- Bridges
- Routers
- Gateway
- Other Shared devices.

### TYPES OF TRANSMISSION

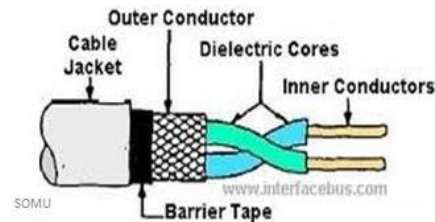
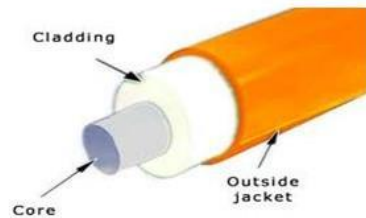
- ANALOG TRANSMISSION
- DIGITAL TRANSMISSION

### MULTIPLEXERS

Multiplexers – is a device that connect several low speed transmission into one high speed transmission

## TRANSMISSION MEDIA

- GUIDED MEDIA
  - TWISTED PAIR CABLE
  - COAXIAL CABLE
  - FIBER OPTIC CABLE
- UNGUIDED MEDIA
  - FREE SPACE



## NETWORK ARCHITECTURES and PROTOCOLS

Network architecture describes the components, the functions performed, and the interfaces and interactions between the components of a network.

### Open system interconnection (OSI) or (ISO/OSI Reference model)

Developed by ISO, to open communication b/w different systems without requiring changes to the logic of the underlying software and hardware

### Manufacturing Automation Protocol (MAP)

subset of the ISO protocol designed to meet the needs of the factory automation

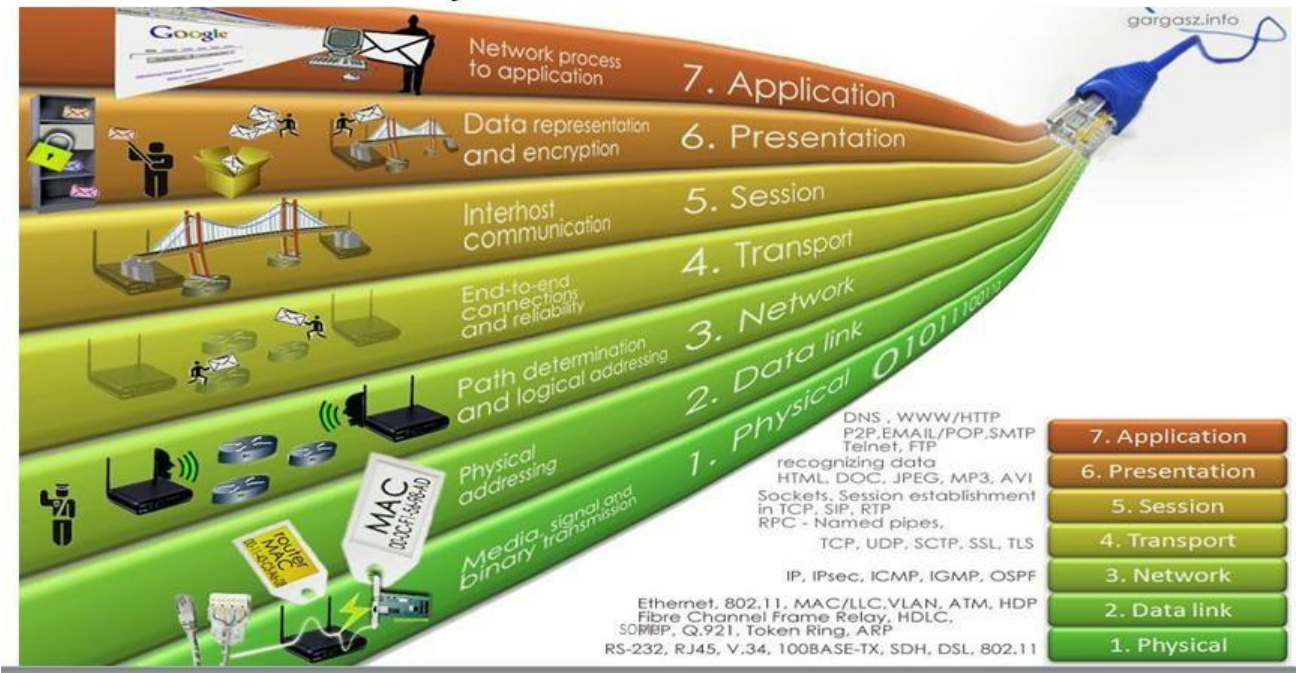
### The Technical and Office Protocol (TOP)

subset of the OSI/ISO standards for technical and office applications

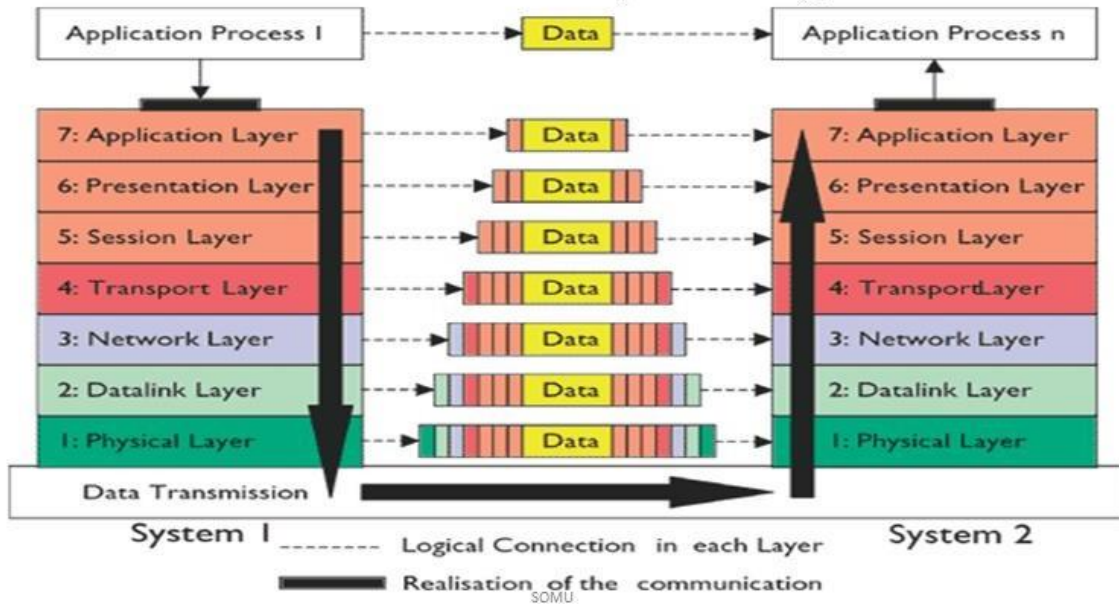


Open system interconnection (OSI)

# OSI model Layer



## Functions of the OSI layer diagram



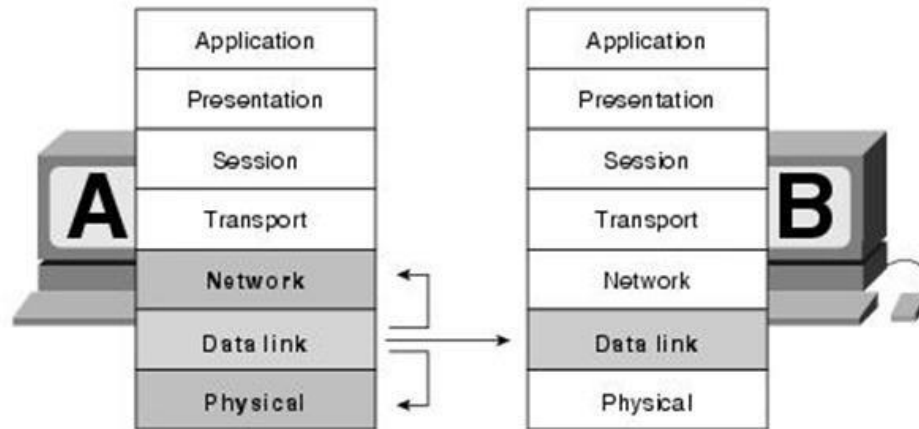


# Functions of the OSI layer

OSI layers	Function	Data type	Protocols	Network components
<b>Application layer</b>	User Application Services ,Allows access to network services that support Applications. Handles network access, Flow control and error recovery.	User Data	DNS; NFS; BOOTP; DHCP; SNMP; RMON; FTP; TFTP; SMTP; POP3; IMAP; NNTP; HTTP; Telnet	Gateway
<b>Presentation layer</b>	Data Translation; Compression and Encryption. All different formats from all sources are made into a common uniform format that the rest of the OSI model can understand.	Encoded User Data	SSL; Shells and Redirectors MIME	Gateway , Redirector
<b>Session layer</b>	Session Establishment, Management And Termination. Manages who can transmit data at a certain time and for how long.	Sessions	NetBIOS, Sockets, Named Pipes, RPC	Gateway
<b>Transport layer</b>	Additional connection below the session layer Manages the flow control of data between parties across the network, Provides flow control and error-handling. <small>SOMU</small>	Datagram's /Segments	TCP and UDP; SPX; NetBEUI/NBF	Gateway , Advanced Cable tester Brouter

<b>Network layer</b>	Translates logical network address and names to their physical address (e.g. computer name to MAC address) Logical Addressing; Routing; Datagram Encapsulation; Fragmentation and Reassembly; Error Handling and Diagnostics	Datagram's / Packets	IP; IPv6; IP NAT; IPSec; Mobile IP; ICMP; IPX; DLC PLP; Routing protocols such as RIP and BGP	Brouter , Router, Frame Relay Device, ATM Switch, Advanced Cable Tester.
<b>Data link layer</b>	Handles data frames between the Network and Physical layers, The receiving end packages raw data from the Physical layer into data frames for delivery to the Network layer, Logical Link Control; Media Access Control; Data Framing; Addressing Error Detection and Handling; Defining Requirements of Physical Layer	Frames	IEEE 802.2 LLC, Ethernet Family; Token Ring; FDDI and CDDI; IEEE 802.11 (WLAN, Wi-Fi); HomePNA ;HomeRF; ATM; SLIP and PPP	Bridge , Switch, ISDN Router, Intelligent,Hub NIC,Advanced Cable Tester
<b>Physical layer</b>	Transmits raw bit stream over physical Cable, Defines cables, cards, and physical Aspects, Defines NIC attachments to hardware, how cable is attached to NIC. Encoding and Signalling; Physical Data Transmission; Hardware Specifications; Topology and Design. <small>SOMU</small>	Bits	EEE 802 IEEE 802.2 ISO 2110 ISDN	Repeater ; Multiplexer; Hubs TDR Oscilloscope Amplify

# MAP layer



**Objective type questions**

1) The network in which computers can act as both servers sharing resources and as clients using the resources is called as,

- a) Server based network
- b) Mesh network
- c) Peer to peer network
- d) None of the above

Ans: Peer to peer network

2) The network in which all computers are connected using a central hub is called as

- a) Star topology
- b) Ring topology
- c) Bus topology
- d) None of the above

Ans: Star topology

3) The topology in which devices connect to a secondary hub that in turn is connected to the central hub:

- a) Tree topology
- b) Ring topology
- c) Bus topology
- d) None of the above

Ans: Tree topology

4) The most common two letter combination are known as

- a) Trigrams
- b) Source route
- c) Diagrams
- d) None of the above

Ans: Diagrams

5) The most common three letter combination are known as

- a) Trigrams
- b) Source route
- c) Diagrams
- d) None of the above

Ans: Triagrams

6) The electronic device that receives a signal and transmits it at a higher power level is:

- a) Bridge
- b) Coaxial cable
- c) Repeater
- d) Hub

CAD/CAM/CIM

Ans: Repeater

7) The hardware/software which connects multiple network segments at the data link layer of the OSI model is:

- a) Bridge
- b) Coaxial cable
- c) Repeater
- d) Hub

Ans: Bridge

8) What flavor of Network Address Translation can be used to have one IP address allow many users to connect to the global Internet?

- a) NAT
- b) Dynamic
- c) Static
- d) PAT

Ans: PAT

9) MRP input requires:

- a) MPS
- b) Inventory
- c) BOM
- d) All of the above

Ans: All of the above

10) CIM is concerned with:

- a) CAD and CAM
- b) CAD and Business function
- c) CAD, CAM and Business function
- d) CAM and marketing

Ans: CAD, CAM and Business function

11) The network layer which deals with issues like „destination address provision:

- a) Network Access layer
- b) Physical layer
- c) Transport layer
- d) None of the above

Ans: Network access layer

12) The device that connects dissimilar networks is termed as:

- a) Bridge
- b) Repeater
- c) Gateway
- d) Router

Ans: Gateway

13) Which types of cables are used in networks:

- a) Coaxial cable
- b) Shielded twisted pair cable
- c) Fiber optic cable
- d) All

Ans: All

14) The type of network that confined to a relatively small area

- a) LAN
- b) MAN
- c) WAN
- d) None of the above

Ans: LAN

15) The network topology consist of a main run of cable with a terminator at each end is termed as:

- a) BUS
- b) TREE
- c) Star
- d) Ring

Ans: BUS

**SNS College of Technology, Coimbatore-35.**  
**(Autonomous)**  
**Seventh Semester**  
**Mechanical Engineering**  
**ME403 – CAD/CAM/CIM**

**IMPORTANT QUESTIONS**

1. Classify different types of network topology with proper explanations and neat sketches
2. Explain briefly about the basic elements and Components of CIM
3. Define communication network. Discuss about the different types of network with proper sketches
4. Review briefly on CIM wheel, CIM concepts and scopes with suitable sketches
5. Illustrate the various types of production and its plant layouts with neat sketch
6. Describe the elements of CAD/CAM Interface
7. Classify the types of network system.
8. Discuss about the benefits of CIM.
9. Discuss about the advantages of communication networking.
10. Outline the major objectives of CIM
11. What is LAN.
12. Explain OSI LAYER

ALL THE BEST