



SNS COLLEGE OF TECHNOLOGY

Coimbatore-35
An Autonomous Institution



Accredited by NBA – AICTE and Accredited by NAAC – UGC with 'A+' Grade
Approved by AICTE, New Delhi & Affiliated to Anna University, Chennai

23MET203 & Engineering Materials and Metallurgy

II YEAR / III SEM

UNIT - 2

CONSTITUTION OF ALLOYS AND PHASE DIAGRAMS

Material Selection

There are over 100,000 engineering materials to choose from. The typical design engineer should have ready access to information on 30 to 60 materials, depending on the range of applications he or she deals with.



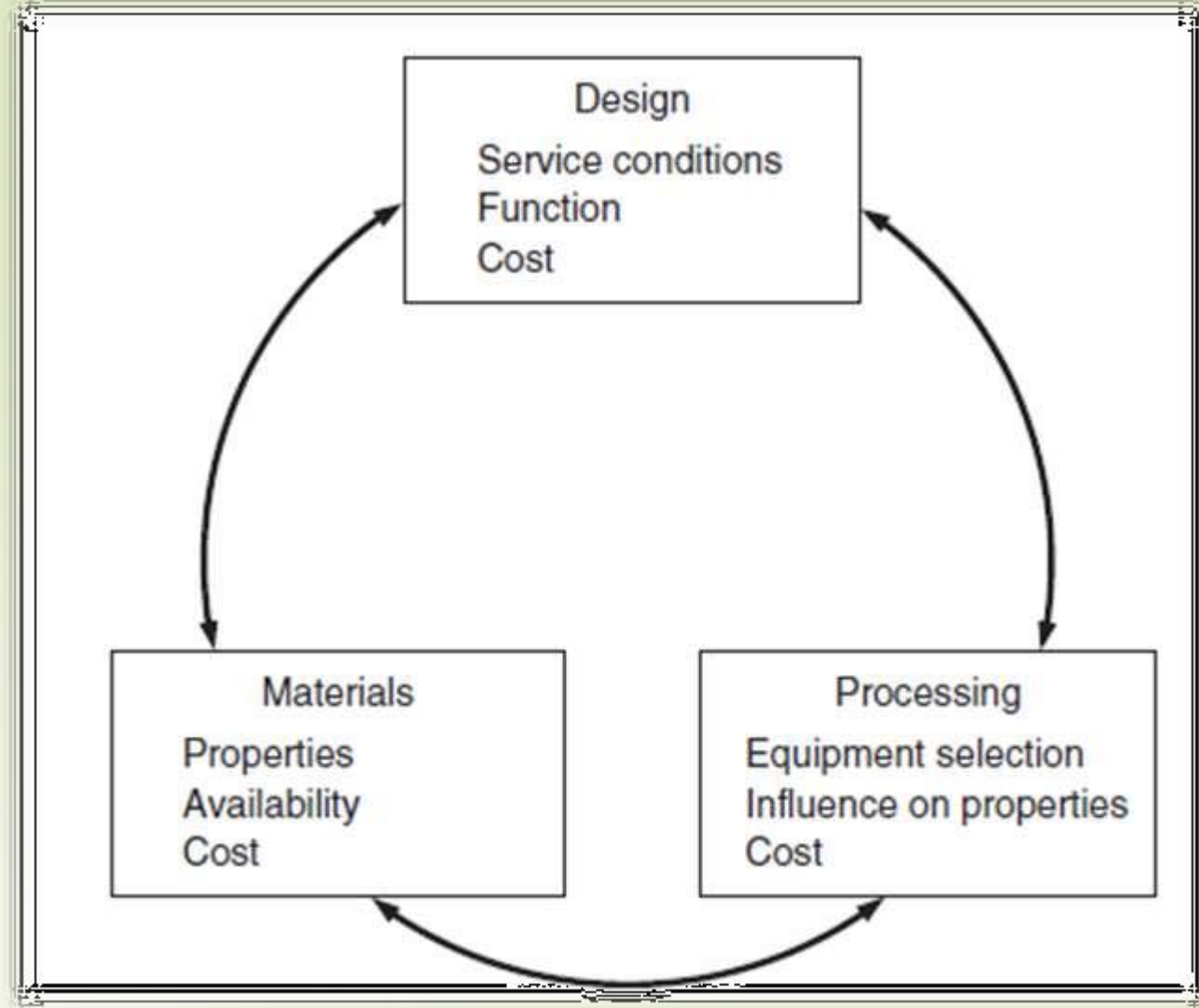

Material Selection Process

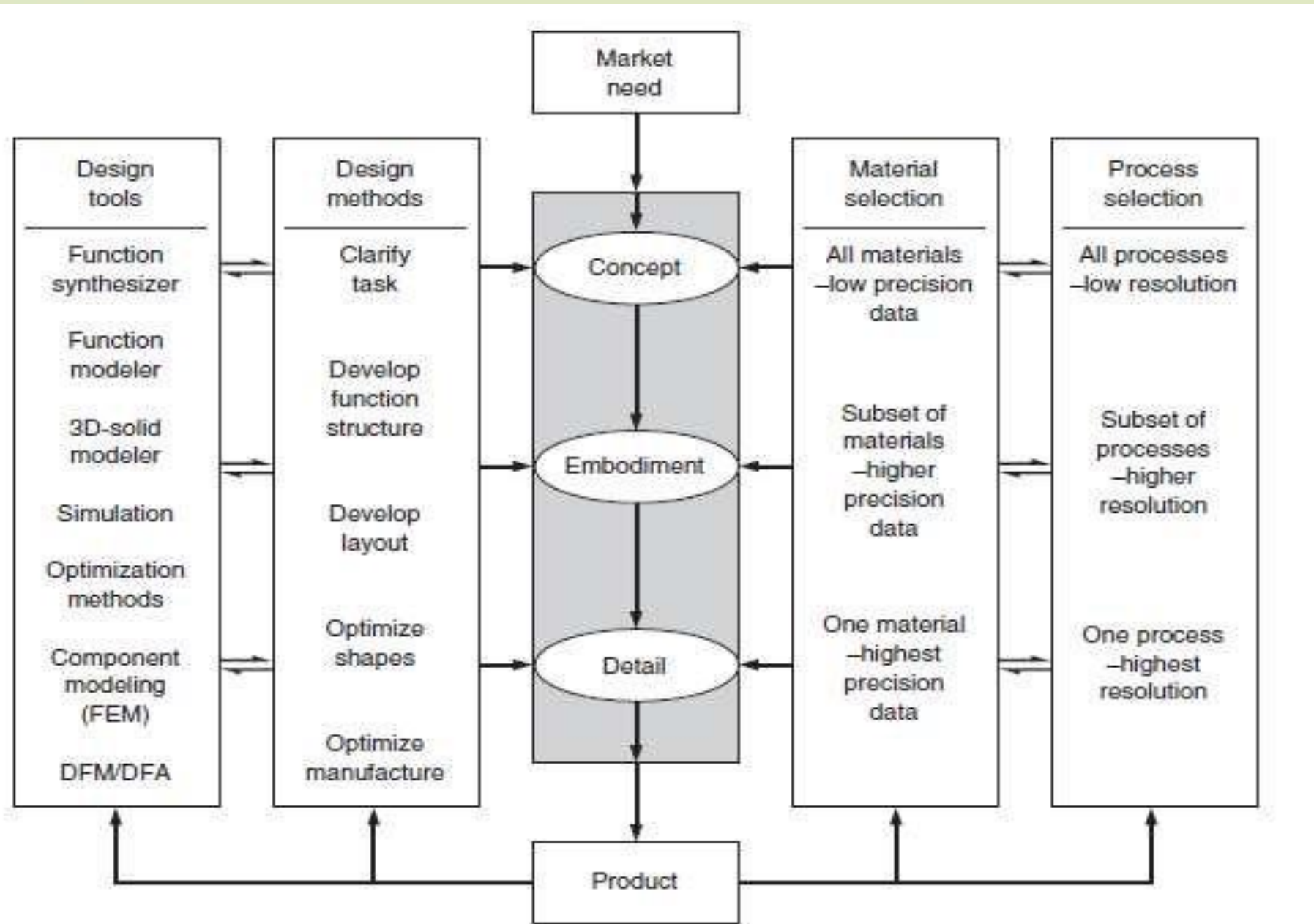

Material Selection Criteria

Materials are selected on the basis of four general criteria:

- Performance characteristics (properties)
- Processing (manufacturing) characteristics
- Environmental profile
- Business considerations

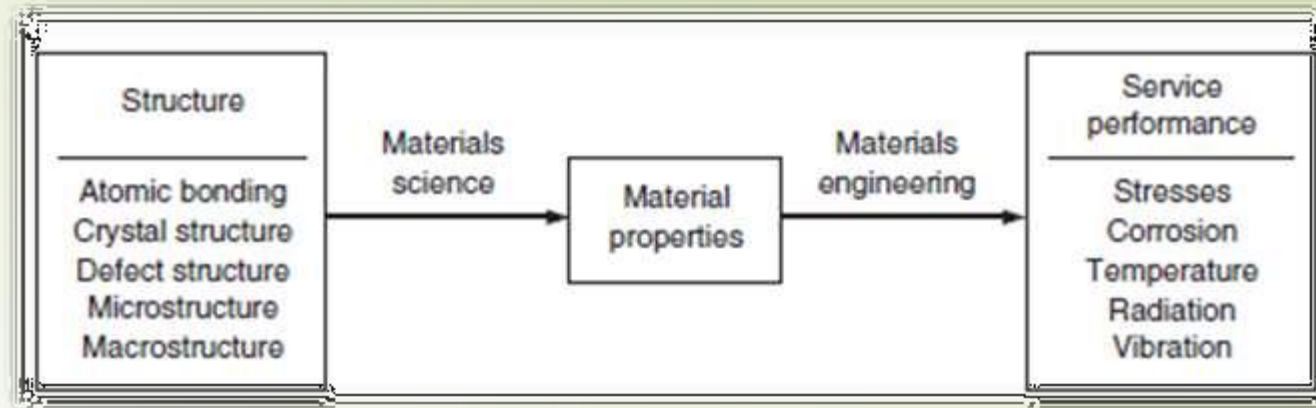

KINGDOM OF ENGINEERING MATERIALS

FAMILY

METALS

POLYMERS

CERAMICS

COMPOSITES

CLASS

Steels

SUBCLASS

Plain carbon steel

MEMBER

AISI 1020

AISI 1040

Alloy steels

AISI 4140

AISI 4340

AISI 8620

Tool steels

O1 Oil hardening

H11 Hot work tool steel

M42 High-speed steel

Cast irons

Gray iron, class 20

Ductile cast iron

Stainless steel

AISI 304

AISI 316

AISI 440C

Aluminum Alloys

3003

6061

7075

380

Copper Alloys

ETP copper-C1100

Yellow brass-C36000

High-Performance Nonferrous Alloys

Inconel 600 - Ni-Cr alloy

Stellite - Co-Cr-W alloy

Ti-6Al-4V

Commodity Thermoplastics

Polyethylene (PE)

Polystyrene (PS)

Polyvinyl chloride (PVC)

Engineering Thermoplastics

Nylon 6/6

ABS

Polycarbonate (PC)

Polyurethane(PUR)

Thermosets-highly crosslinked

Alkyds

Epoxies

Phenolics

Polyesters

Elastomers

Rubbers

Silicone resins

Carbides, Oxides, Nitrides

Alumina, Al_2O_3

Silicon carbide, SiC

Silicon nitride, Si_3N_4

Toughened zirconia, ZrO_2

Cemented Carbides

WC-6% Co

Carbon

Carbon fibers

Graphite

Building Materials

Bricks

Concrete

Glass

Wood

Fiber-Reinforced

Carbon fiber-polymer matrix

Glass fiber-polymer matrix

Laminated composite

A Short List of Material Properties

Structure-Insensitive Properties

Melting point, T_m

Glass transition temperature, for polymers, T_g

Density, ρ

Porosity

Modulus of elasticity, E

Coefficient of linear thermal expansion, α

Thermal conductivity, k

Specific heat, c_p

Corrosion rate

Structure-Sensitive Properties

Strength, σ_f , where f denotes a failure mode

Ductility

Fracture toughness, K_{Ic}

Fatigue properties

Damping capacity, η

Creep

Impact or shock loading resistance

Hardness

Wear rate or corrosion rate

Material Selection Criteria's

1. Availability

- Are there multiple sources of supply?
- What is the likelihood of availability in the future?
- Is the material available in the forms needed (tubes, wide sheet, etc.)?

2. Size limitations and tolerances on available material shapes and forms,
e.g., sheet thickness or tube wall concentricity

3. Excessive variability in properties

4. Environmental impact, including ability to recycle the material

5. Cost. Materials selection comes down to buying properties at the best available price

Material Selection Example

Consider the question of materials selection for an **automotive exhaust system**. The product design specification states that it must provide the following functions:

- ✓ Conduct engine exhaust gases away from the engine
- ✓ Prevent noxious fumes from entering the car
- ✓ Cool the exhaust gases
- ✓ Reduce the engine noise
- ✓ Reduce the exposure of automobile body parts to exhaust gases
- ✓ Affect the engine performance as little as possible
- ✓ Help control unwanted exhaust emissions
- ✓ Have an acceptably long service life
- ✓ Have a reasonable cost, both as original equipment and as a replacement part

Material Requirements for an Automotive Exhaust System

Mechanical property requirements not overly severe.

- Suitable rigidity to prevent excessive vibration
- Moderate fatigue resistance
- Good creep resistance in hot parts

Limiting property:

corrosion resistance , especially in the cold end where gases condense to form corrosive liquids.

Properties of unique interest:

The requirements are so special that only a few materials meet them regardless of cost.

- Pt-base catalysts in catalytic converter
- Special ceramic carrier that supports the catalyst

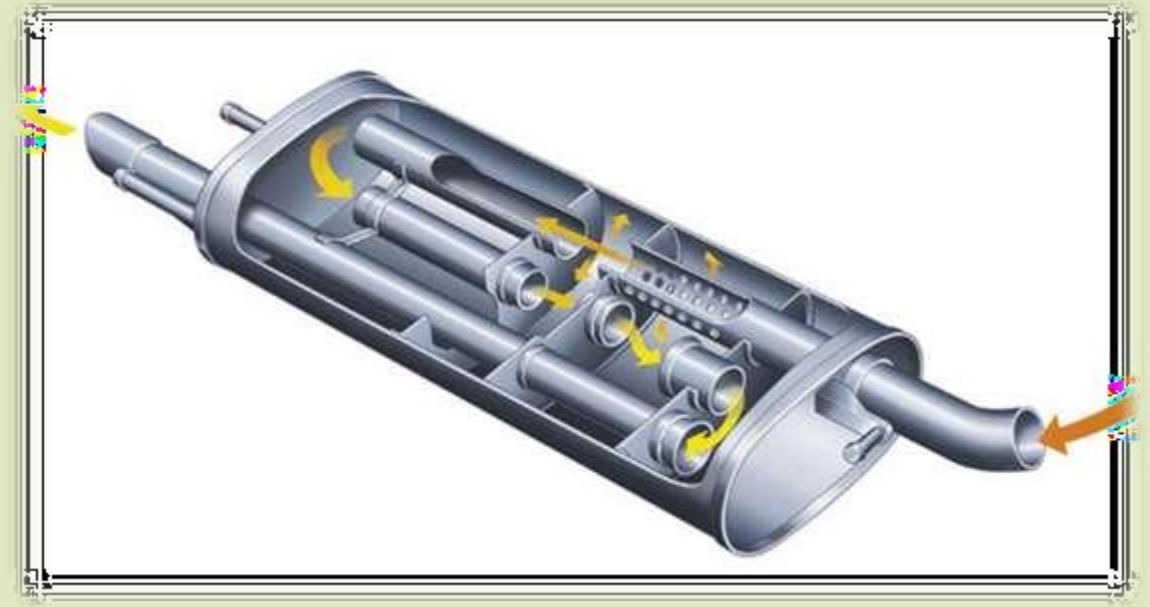

Previous materials used:

Low-carbon steel with corrosion-resistant coatings.

Material is relatively inexpensive, readily formed and welded. Life of tailpipe and muffler is limited.

Newer materials used:

With greater emphasis on automotive quality, many producers have moved to specially developed stainless steels with improved corrosion and creep properties. Ferritic 11% Cr alloys are used in the cold end components and 17 to 20% Cr ferritic alloys and austenitic Cr-Ni alloys in the hot end of the system.



Why these materials are suitable for particular applications as mentioned bellow



Rubber as Washer



Steel as structure support



Polythene as bag



Thermocol for packing



Leather as Belt



Titanium alloy for Medical Implants

Tolerance

- A tolerance is the permissible variation from the specified dimension
- The designer must decide how much variation is allowable from the basic dimension of the component to accomplish the desired function.
- The tolerance on a part is the difference between the upper and lower allowable limits of a basic size dimension

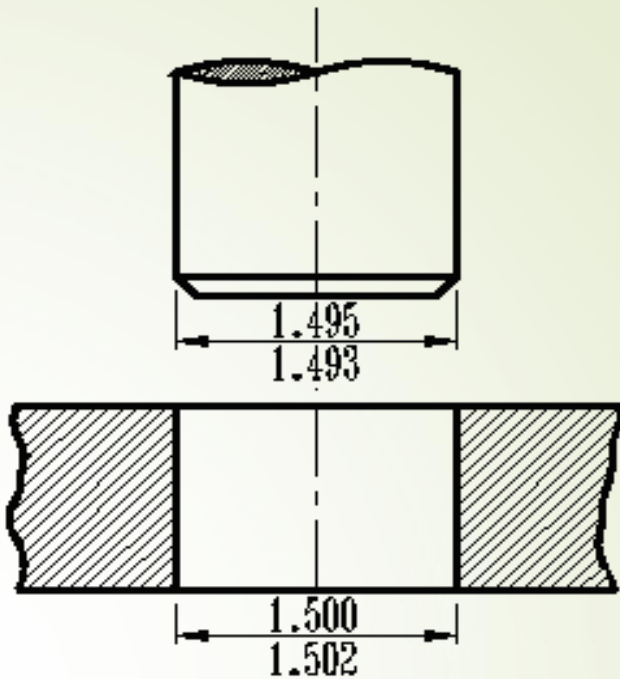

Each manufacturing process has an inherent ability to maintain a certain range of tolerances, and to produce a certain surface roughness (finish). To achieve tolerances outside of the normal range requires special processing that typically results in an **exponential increase in the manufacturing cost.**

Types of Tolerance

Bilateral tolerance

The variation occurs in both directions from the basic dimension. That is, the upper limit exceeds the basic value and the lower limit falls below it.

2.500 ± 0.005 (This is the most common way of specifying tolerances)

Unilateral tolerance:

The basic dimension is taken as one of the limits, and variation is in only one direction

$$2.500^{+0.000}_{-0.010}$$

Standards & Codes in Design

Code is a collection of laws and rules that assists a government agency in meeting its obligation to protect the general welfare by preventing damage to property or injury or loss of life to persons.

Standard is a generally agreed-upon set of procedures, criteria, dimensions, materials, or parts. Engineering standards may describe the dimensions and sizes of small parts like screws and bearings, the minimum properties of materials, or an agreed-upon procedure to measure a property like fracture toughness.



Some Background:

- ▮ The U.S. federal government is the largest single creator and user of standards: more than 45,000 (by current estimates)!
- ▮ About 210 organization are designated Standard Development Organizations (SDO's)
- ▮ Most Standards (about 90%) come from about 20 of these SDO's
- ▮ ASTM, ASME, IEEE, AISI (ASM), ASCE, MilStd (Mil Specs), are some of the most important SDO's



Taking them Global!

- ANSI and (U.S. National Committee (USNC)) are the U.S. clearing house for Standards and a founding member of ISO!
- Internationally we see Standard Organization in each of the major Industrial Nations and several Umbrella Groups:
 - International Organization for Standardization (ISO)
 - International Electro-technical Commission (IEC)
 - International Telecommunication Union (ITU)



Why Standards & Codes ?



- it makes the best practice available to everyone, thereby ensuring efficiency and safety.
- it promotes interchangeability and compatibility. With respect to the second point, anyone who has traveled widely in other countries will understand the compatibility problems with connecting plugs and electrical voltage and frequency when trying to use small appliances

How they're used:

- ▣ Standards are a “COMMUNICATION” tool that allows all users to speak the same language when reacting to products or processes
- ▣ They provide a “Legal,” or at least enforceable, means to evaluate acceptability and saleability of products and/or services
- ▣ They can be taught and applied globally!
- ▣ They, ultimately, are designed to protect the public from questionable designs, products and practices
- ▣ They teach us, as engineers, how we can best meet environmental, health, safety and societal responsibilities



Organization	Initials	Country
Bureau of Indian Standards	BIS	India
Badan Standardisasi Nasional	BSN	Indonesia
Brazilian National Standards Organization	ABNT	Brazil
Spanish Association for Standardization and Certification	AENOR	Spain
French association for Standardization	AFNOR	France
American National Standards Institute	ANSI	U.S.
British Standards Institution	BSI	U.K.
Dirección General de Normas	DGN	Mexico
Deutsches Institut für Normung	DIN	Germany
Instituto Argentino de Normalización y Certificación	IRAM	Argentina
Bureau of Standards of Jamaica	BSJ	Jamaica
Euro-Asian Council for Standardization, Metrology and Certification	GOST	Russia (Soviet Union)
Colombian Institute of Technical Standards and Certification	ICONTEC	Colombia
Luxembourg Institute for Standardization, Accreditation, Security, and Quality of Products and Services	ILNAS	Luxembourg
Japanese Industrial Standards Committee	JISC	Japan
Korean Agency for Technology and Standards	KATS	Korea (Republic)
Nederlandse Norm	NEN	Netherlands
South African Bureau of Standards	SABS	South Africa
Standardization Administration of China	SAC	China
Standards Council of Canada	SCC	Canada
Swedish Standards Institute	SIS	Sweden
Finnish Standards Association	SFS	Finland



Thank You!
😊