



SNS COLLEGE OF TECHNOLOGY, COIMBATORE-35
DEPARTMENT OF MECHANICAL ENGINEERING

Fluid Mechanics and Machinery –

UNIT 3 FLOW OVER FLAT PLATE AND FLOW THROUGH CIRCULAR CONDUITS

Topic - Hydraulic and energy gradient



Hydraulic and energy gradient lines are simple graphical representation of how the flow energy behaves along a direction.

The rough idea that lies behind flow energy is unless a flow is inviscid (zero viscosity), the whole amount of available energy will decrease because of friction.

Friction create head losses, thus energy decrease.

For practical purposes, I will assume energy is expressed in terms of head, expressed in meters.

The total energy available in a flow, at a specific position, noted H can be written as follows:

$$H = \frac{P}{\rho g} + z + \frac{V^2}{2g}$$

This total energy head is a sum of three energy heads :

- A pressure head, $\frac{P}{\rho g}$
- A potential head, z
- A kinetic head, $\frac{V^2}{2g}$

The Total Energy Line, also commonly referred as the Energy Grade Line (EGL) is a graphical representation of the aforementioned total head H.

Now consider a flow standing still. Which is not moving at all. In that case, the kinetic head becomes zero. The remaining head is somehow referred as "static head". It is just the total energy head minus the velocity head.



SNS COLLEGE OF TECHNOLOGY, COIMBATORE-35
DEPARTMENT OF MECHANICAL ENGINEERING

Fluid Mechanics and Machinery –

UNIT 3 FLOW OVER FLAT PLATE AND FLOW THROUGH CIRCULAR CONDUITS

Topic - Hydraulic and energy gradient



$$H_{static} = \frac{P}{\rho g} + z = H - \frac{V^2}{2g}$$

The Hydraulic Grade Line (HGL) is just a graphical representation of this static head. Therefore, one can make the following deductions:

The line representing the sum of pressure head (p/w) and potential head or datum head (z) with respect to some reference line is hydraulic gradient line (H.G.L) also called as piezometric head.

- The Hydraulic Grade Line (HGL) lies one velocity head below the the Energy Grade Line (EGL)
- The line representing the sum of pressure head (p/w), datum head (z) and velocity head with respect to some reference line is known as total energy line (T.G.L).

Velocity head is given by:

$$V^2 / 2g$$

- In case the cross section is constant along the streamline and the flow steady, discharge remains constant and also so does velocity. Therefore, velocity head remains the same aswell. In that case, HGL will always remain parallel to EGL.

To understand further watch:

Web sources

<https://www.youtube.com/watch?v=-oecDDrYfyY>

<https://www.quora.com/How-can-I-understand-hydraulic-gradient-line-and-total-energy-line>

<https://www.youtube.com/watch?v=q89YrFmyHY4>

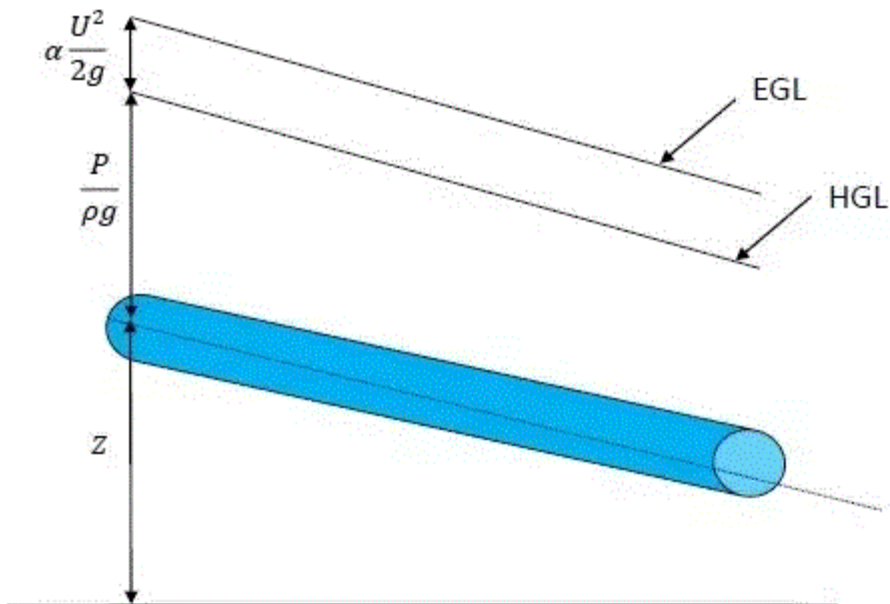

in case the fluid goes through a pump, energy increases suddenly

Grade Line Interpretation - Pump

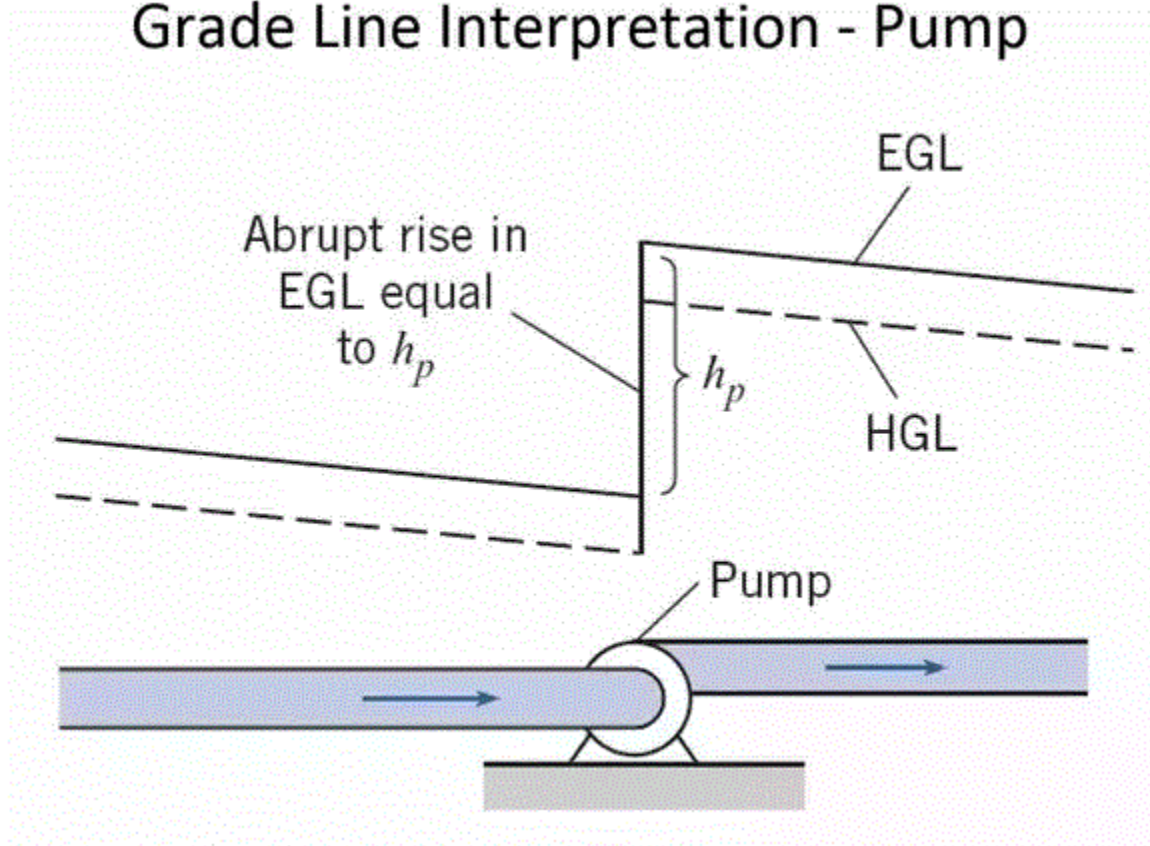



SNS COLLEGE OF TECHNOLOGY, COIMBATORE-35
DEPARTMENT OF MECHANICAL ENGINEERING

Fluid Mechanics and Machinery –

UNIT 3 FLOW OVER FLAT PLATE AND FLOW THROUGH CIRCULAR CONDUITS

Topic - Hydraulic and energy gradient



And it will decrease suddenly if it goes through a turbine.

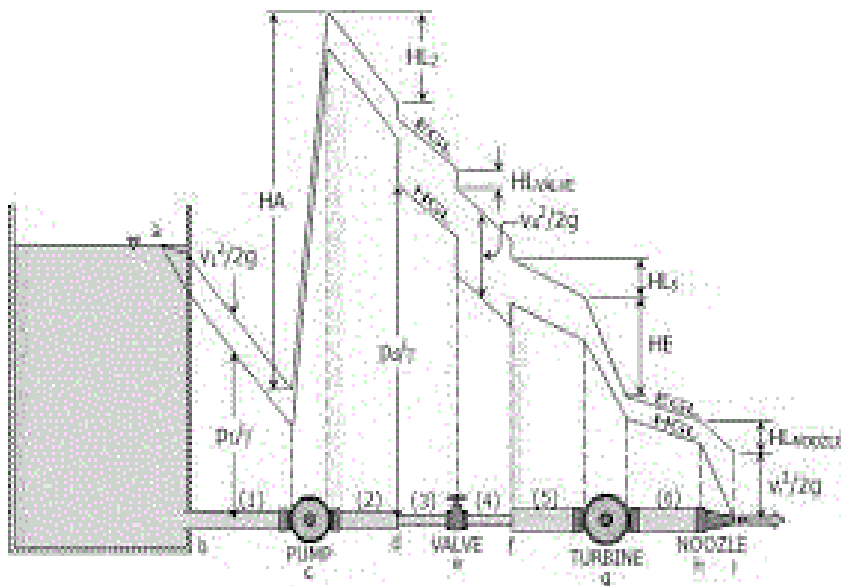



UNIT 3 FLOW OVER FLAT PLATE AND FLOW THROUGH CIRCULAR CONDUITS

Topic - Hydraulic and energy gradient

Hydraulic Grade Line (H.G.L)

- It is useful for the study of flow of fluid in pipes.

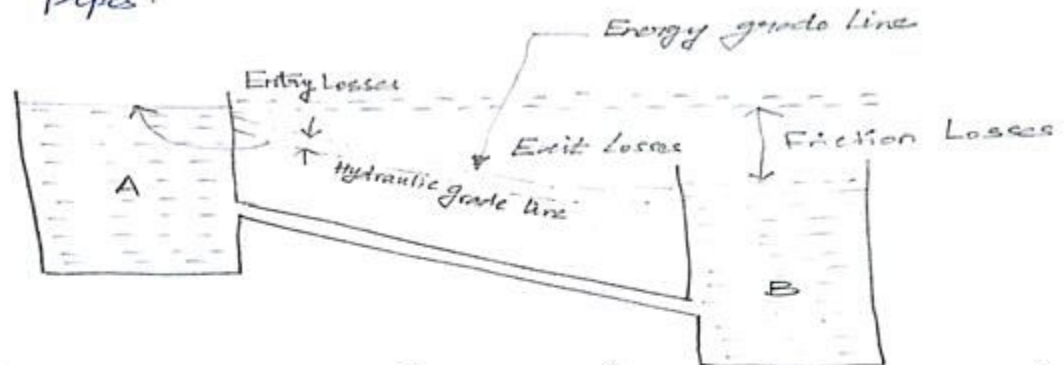

- Consider a pipeline carrying liquid from a reservoir A to B.
- Let piezometers are installed at several points along the pipe line.
- The liquid will rise in the piezometers to some heights corresponding to the pressure head at each section.
- The height of the liquid surface above the axis of the pipe in the piezometers of any section will be equal to pressure head $\frac{P}{\rho g}$ at that section.
- This pressure head will decrease gradually from section to section of the pipe in the direction of flow due to loss of energy.



SNS COLLEGE OF TECHNOLOGY, COIMBATORE-35
DEPARTMENT OF MECHANICAL ENGINEERING

Fluid Mechanics and Machinery –

UNIT 3 FLOW OVER FLAT PLATE AND FLOW THROUGH CIRCULAR CONDUITS

Topic - Hydraulic and energy gradient



- If a straight line, Joins Pressure heads at different sections of the pipe, a straight slopping line will be obtained.

This line is known as Hydraulic Grade Line or Pressure line. (HGL)

- It refers $(\frac{P}{w} + z)$ at any point along the pipeline.
- Total Energy Gradient Line (T.E.L.)

Considering the above sketch

- If z is the height of the pipe axis above an arbitrary datum.
- The vertical height of the hydraulic grade line above the datum at that section of the pipe represents the piezometric headline.
- at different sections of the pipe the total energy $(\frac{P}{w} + \frac{V^2}{2g} + z)$ is plotted to scale and joined by a line.
- The line so defined is called Total Energy gradient Line (T.E.L.).