



SNS COLLEGE OF TECHNOLOGY

Coimbatore-35
An Autonomous Institution



Accredited by NBA – AICTE and Accredited by NAAC – UGC with 'A++' Grade
Approved by AICTE, New Delhi & Affiliated to Anna University, Chennai

DEPARTMENT OF ELECTRONICS & COMMUNICATION ENGINEERING

23ECB201 – DIGITAL SYSTEMS DESIGN

II YEAR/ III SEMESTER

UNIT 2 – COMBINATIONAL CIRCUITS

TOPIC- 2.3 – MULTIPLEXER and DEMULTIPLEXER



What is a Multiplexer?

- Multiplexer is a combinational circuit that has maximum of 2^n data inputs, 'n' selection lines and single output line.
- One of these data inputs will be connected to the output based on the values of selection lines..

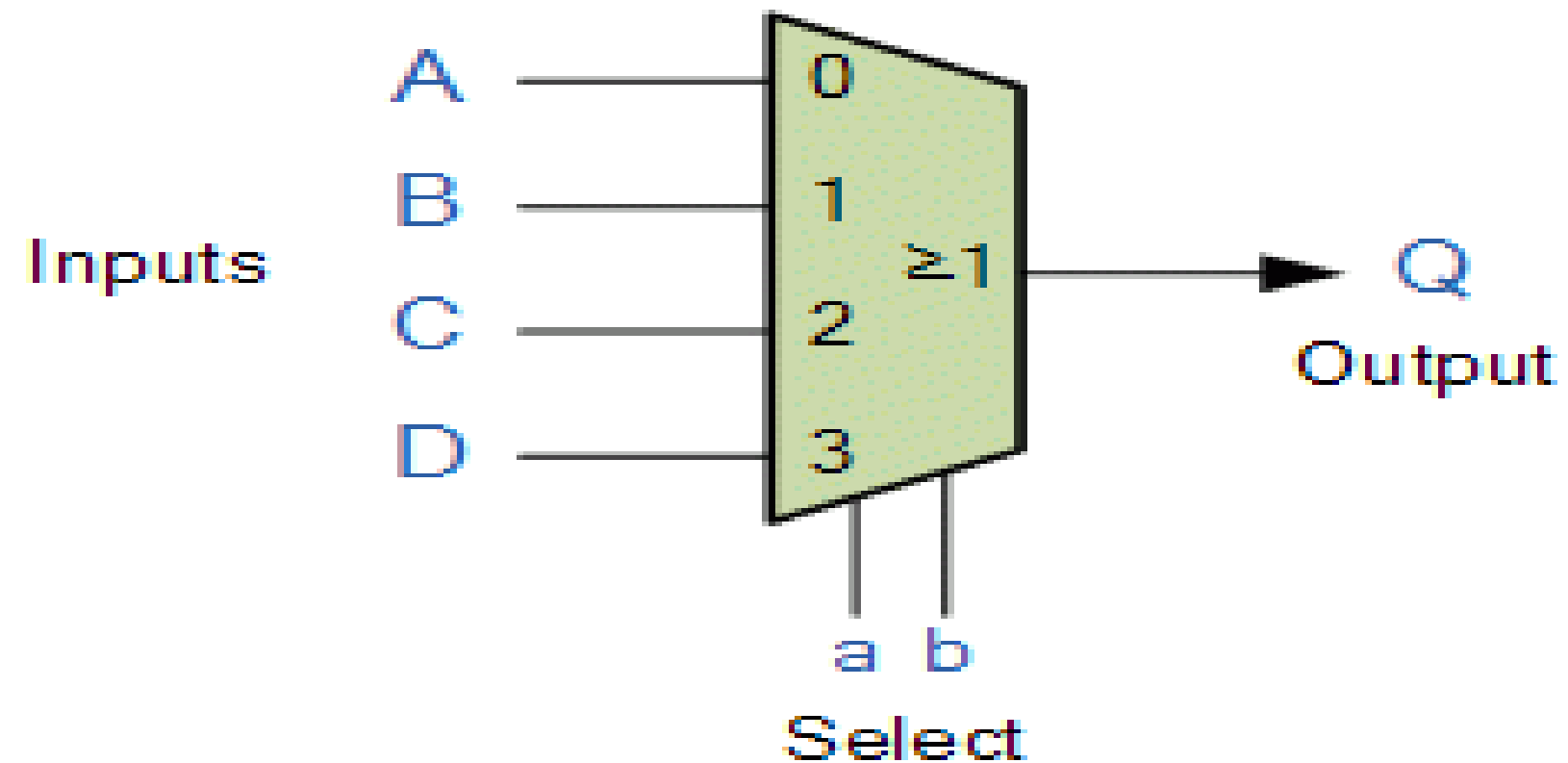
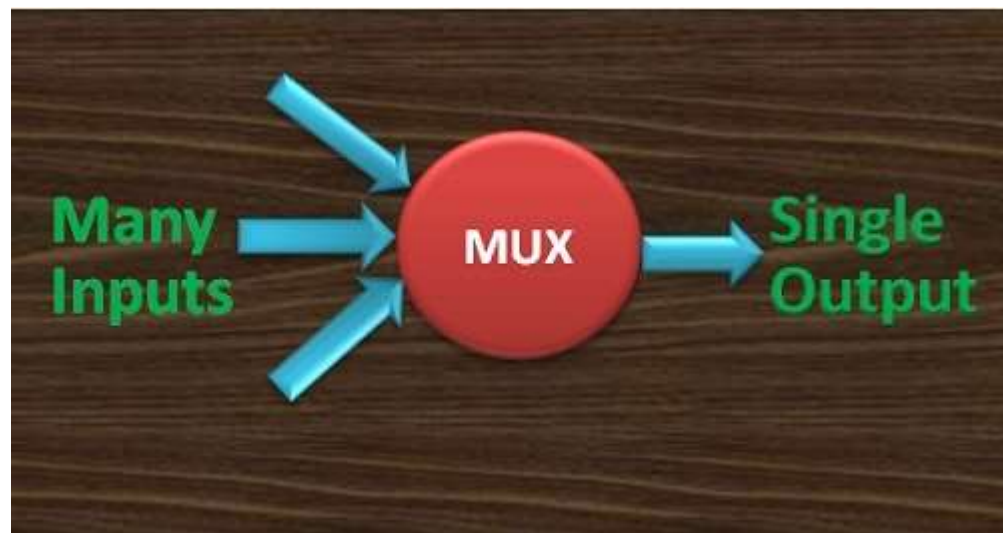



Multiplexing Techniques

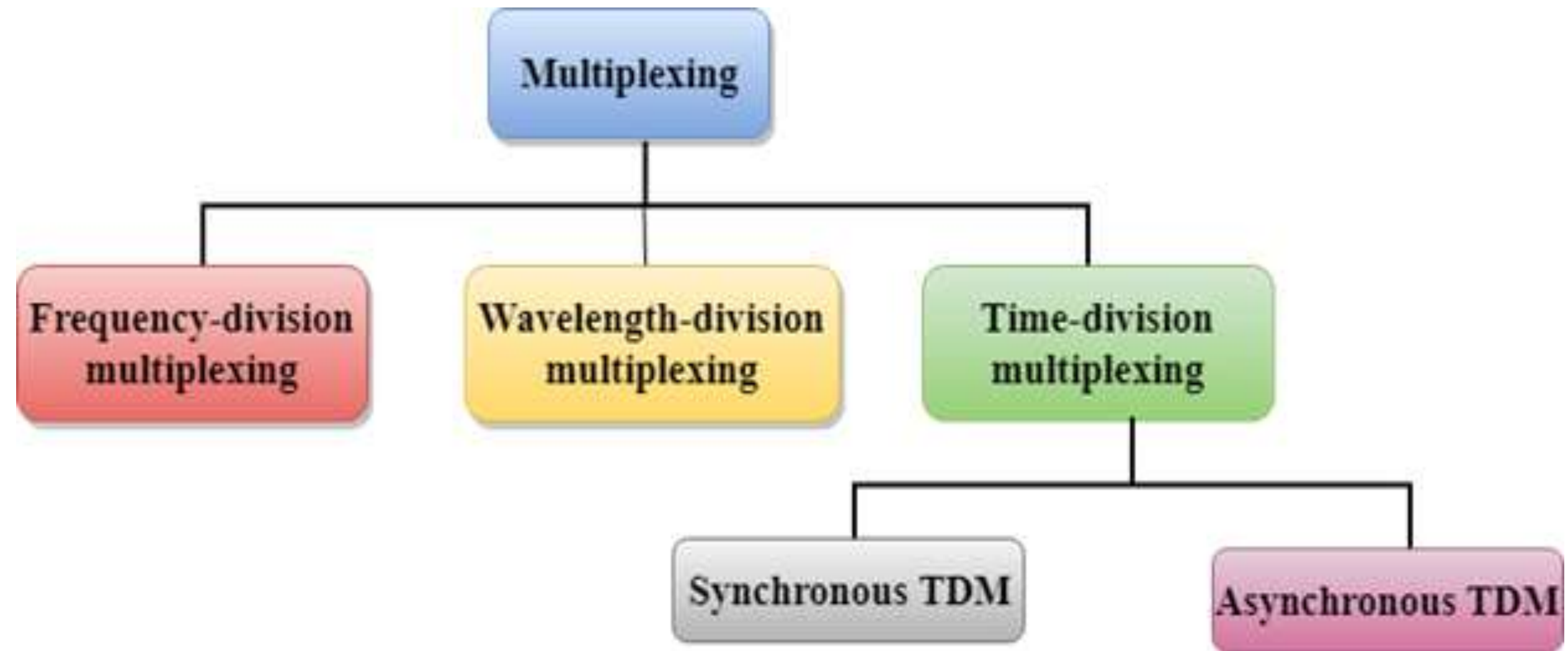



4x1 Multiplexer

- 4x1 Multiplexer has four data inputs I_3 , I_2 , I_1 & I_0 , two selection lines s_1 & s_0 and one output Y .

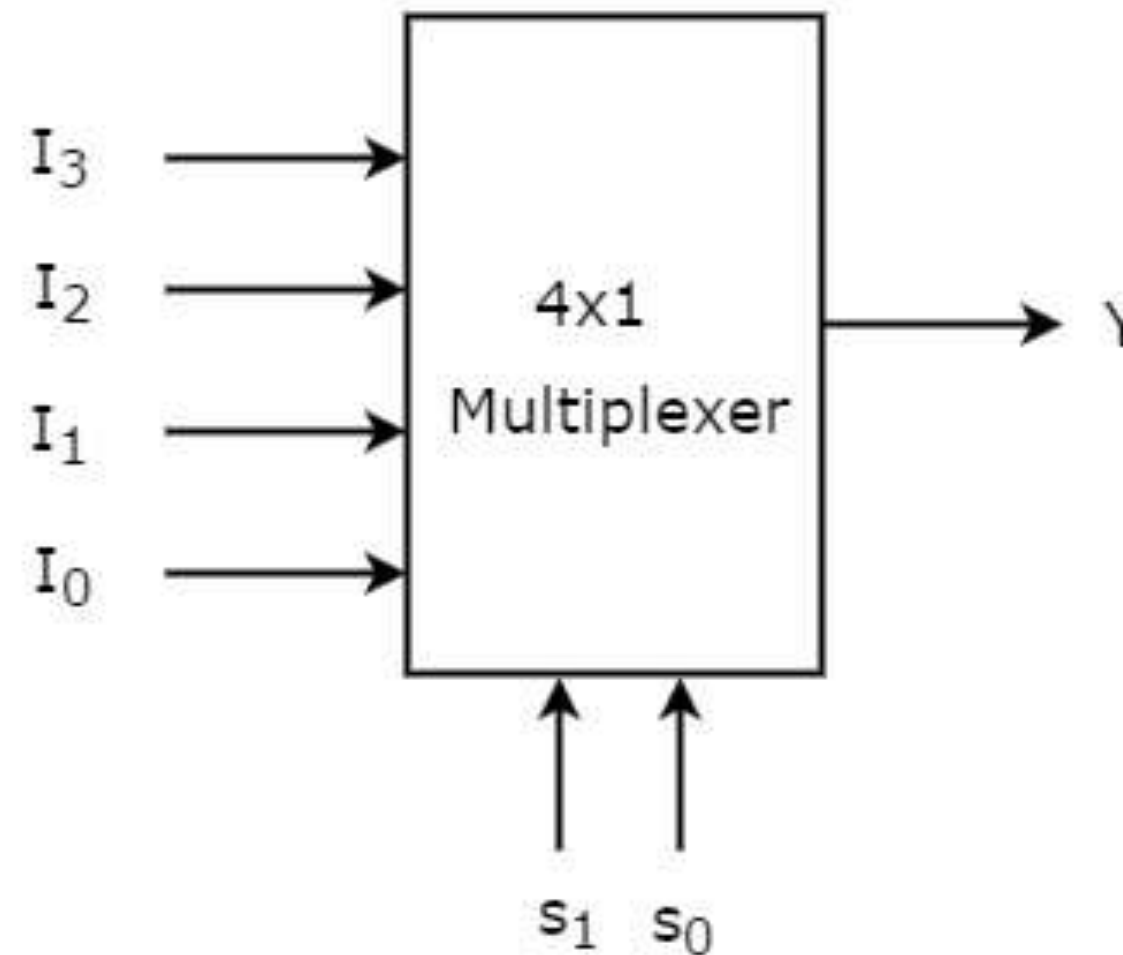



4x1 Multiplexer

- One of these 4 inputs will be connected to the output based on the combination of inputs present at these two selection lines.

Selection Lines		Output
S_1	S_0	Y
0	0	I_0
0	1	I_1
1	0	I_2
1	1	I_3



4x1 Multiplexer



- We can implement this Boolean function using Inverters, AND gates & OR gate.

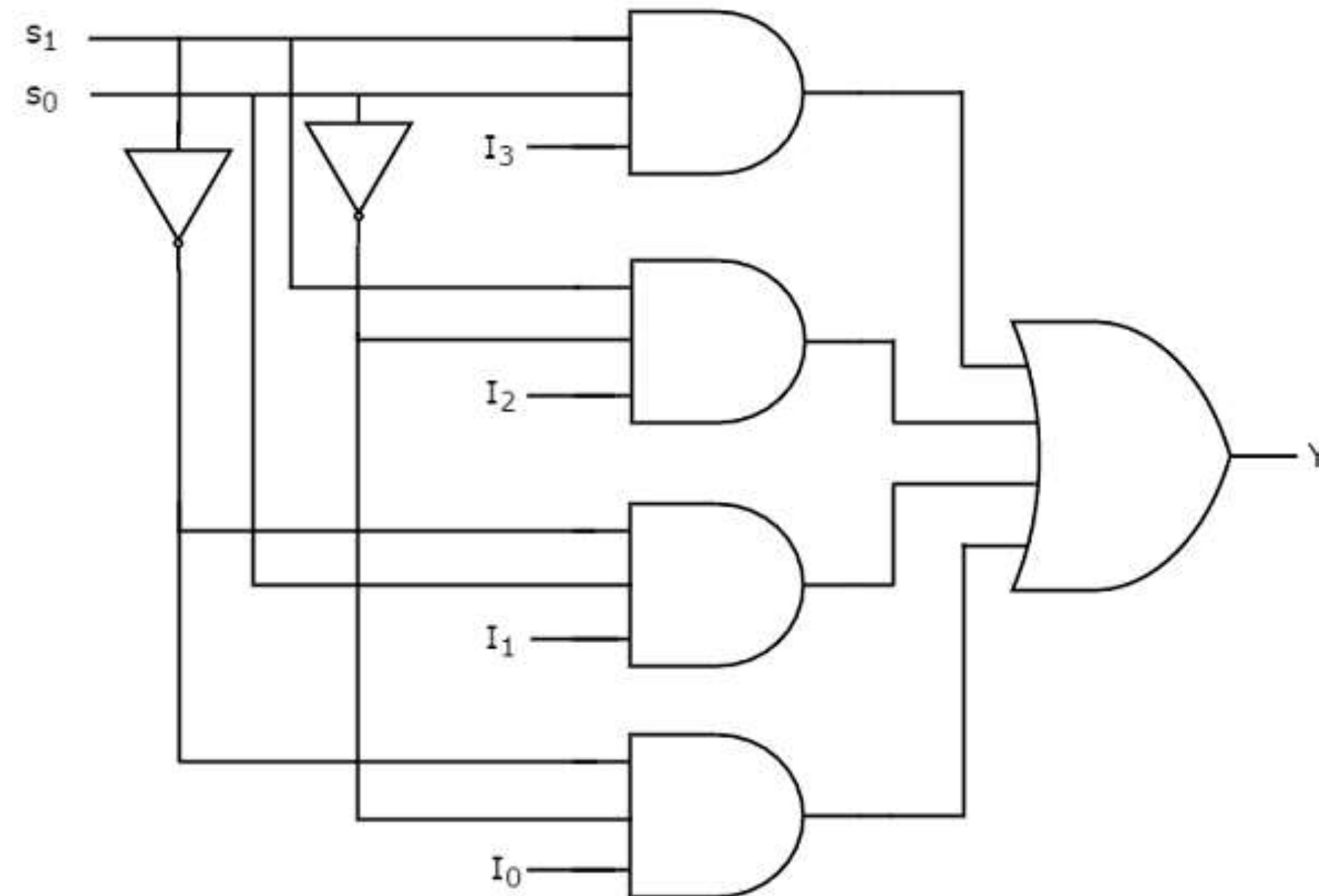



8x1 Multiplexer



- We require two 4x1 Multiplexers in first stage in order to get the 8 data inputs.

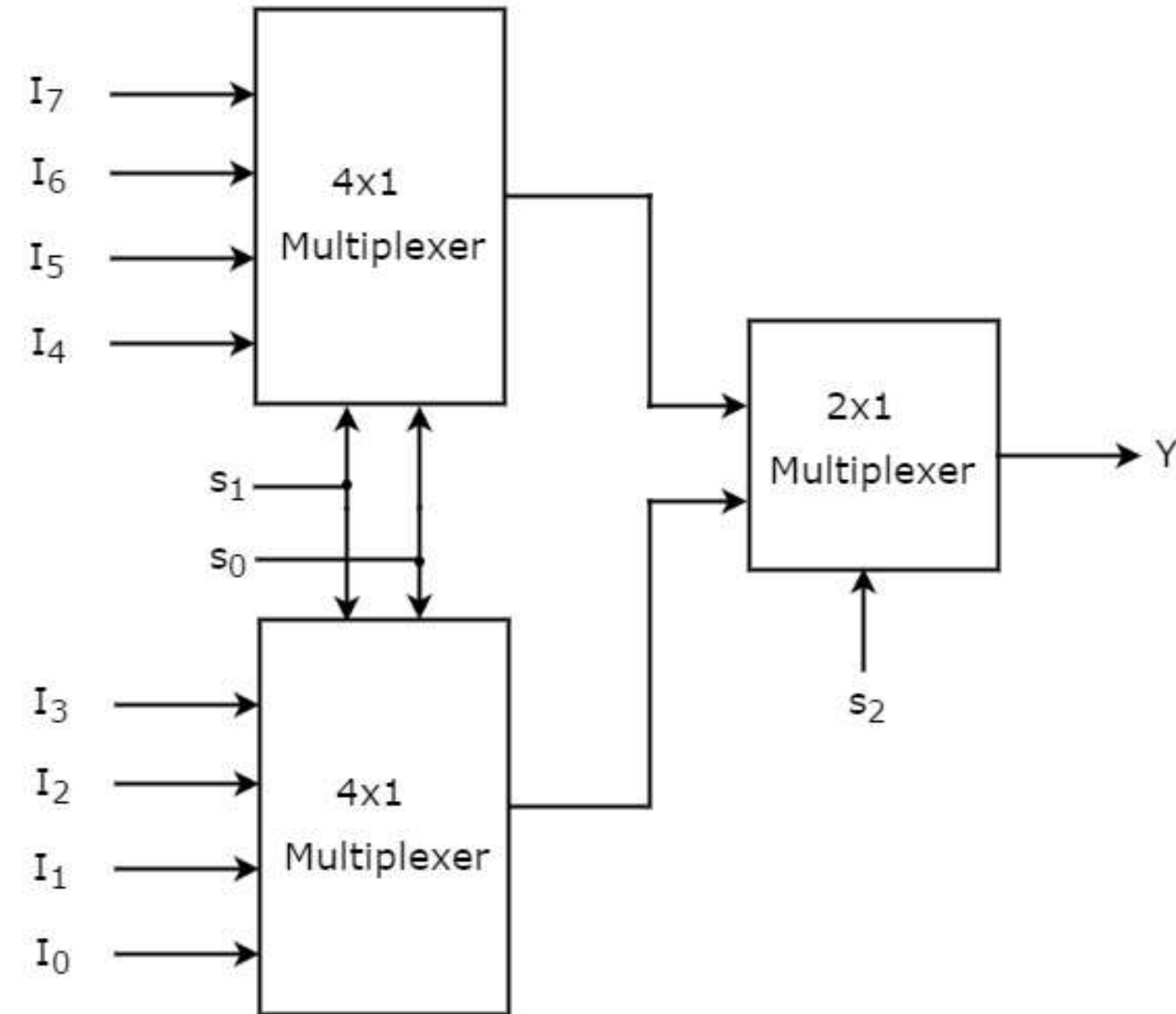



8x1 Multiplexer



- Let the 8x1 Multiplexer has eight data inputs I_0 to I_7 , three selection lines s_2 , s_1 & s_0 and one output Y

Selection Inputs			Output
S_2	S_1	S_0	Y
0	0	0	I_0
0	0	1	I_1
0	1	0	I_2
0	1	1	I_3
1	0	0	I_4
1	0	1	I_5
1	1	0	I_6
1	1	1	I_7



Activity Time





16x1 Multiplexer

➤ We require two 8x1 Multiplexers in first stage in order to get the 16 data inputs.

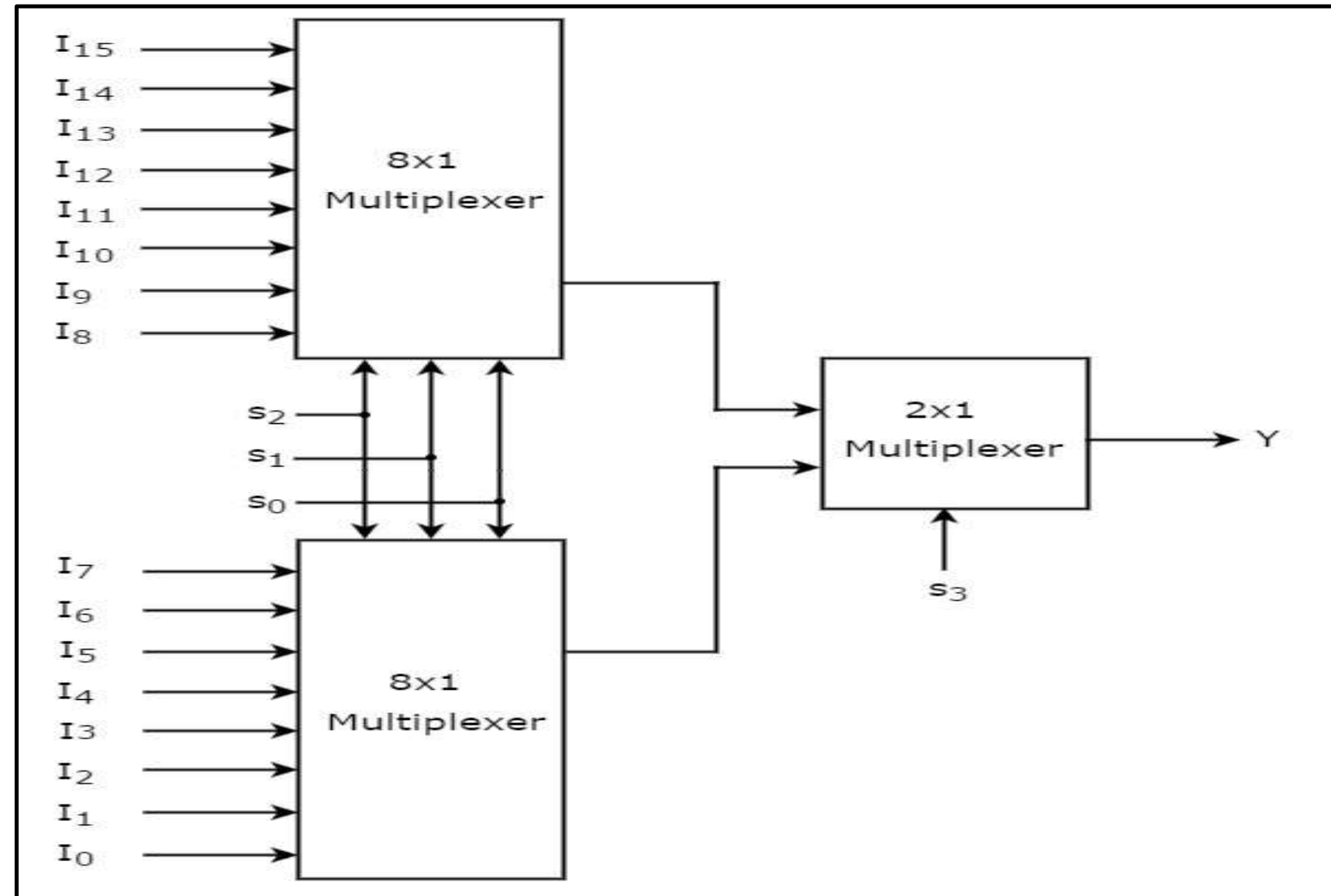



16x1 Multiplexer

- 16x1 Multiplexer has sixteen data inputs I_{15} to I_0 , four selection lines s_3 to s_0 and one output Y .

Selection Inputs				Output
s_3	s_2	s_1	s_0	Y
0	0	0	0	I_0
0	0	0	1	I_1
0	0	1	0	I_2
0	0	1	1	I_3
0	1	0	0	I_4
0	1	0	1	I_5
0	1	1	0	I_6
0	1	1	1	I_7
1	0	0	0	I_8

1	0	0	1	I_9
1	0	1	0	I_{10}
1	0	1	1	I_{11}
1	1	0	0	I_{12}
1	1	0	1	I_{13}
1	1	1	0	I_{14}
1	1	1	1	I_{15}



Typical Application of a MUX

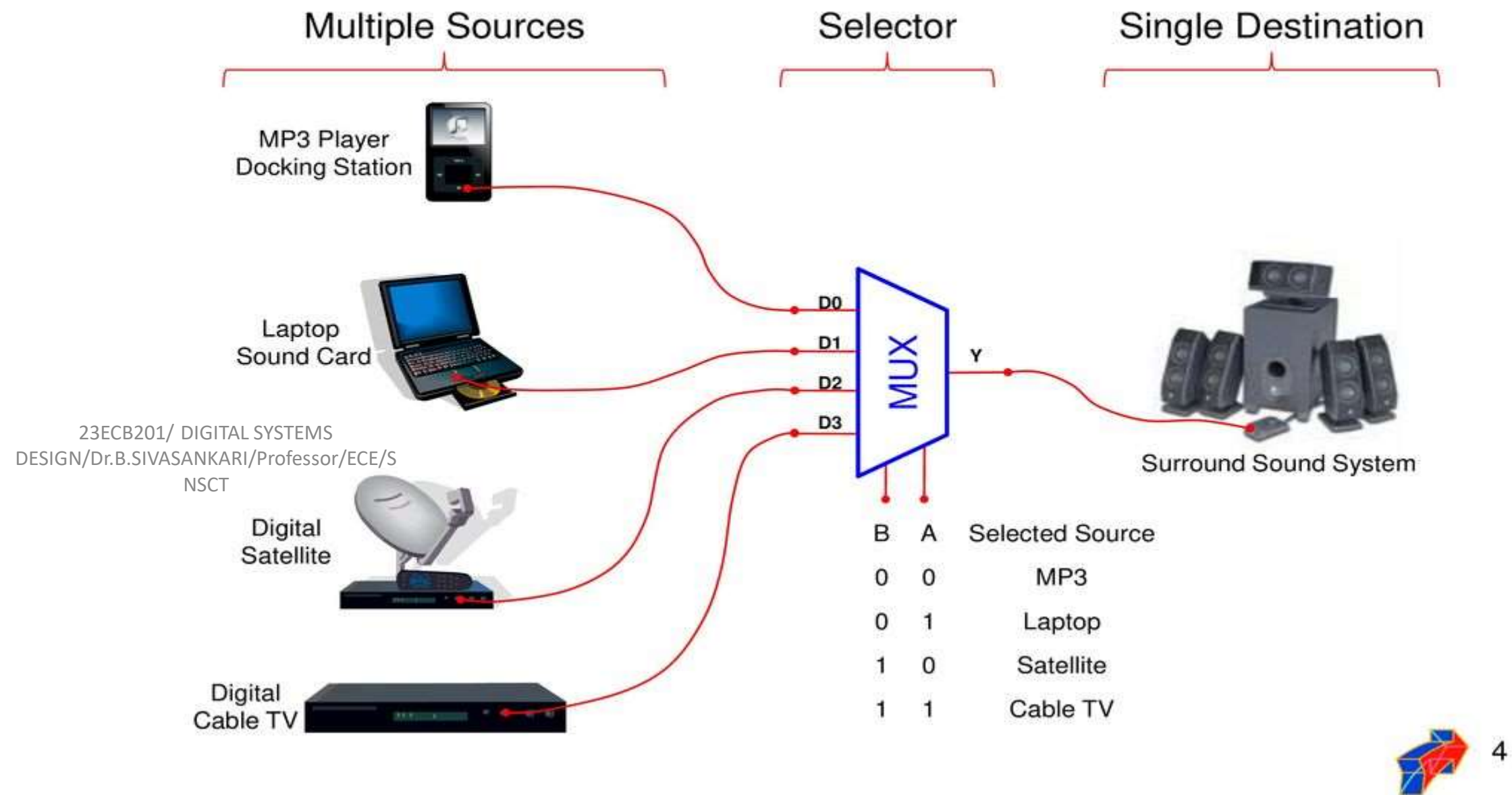



What is De Multiplexer?

- De-Multiplexer is a combinational circuit that performs the reverse operation of Multiplexer. It has single input, 'n' selection lines and maximum of 2^n outputs.
- One of these data inputs will be connected to the output based on the values of selection lines..

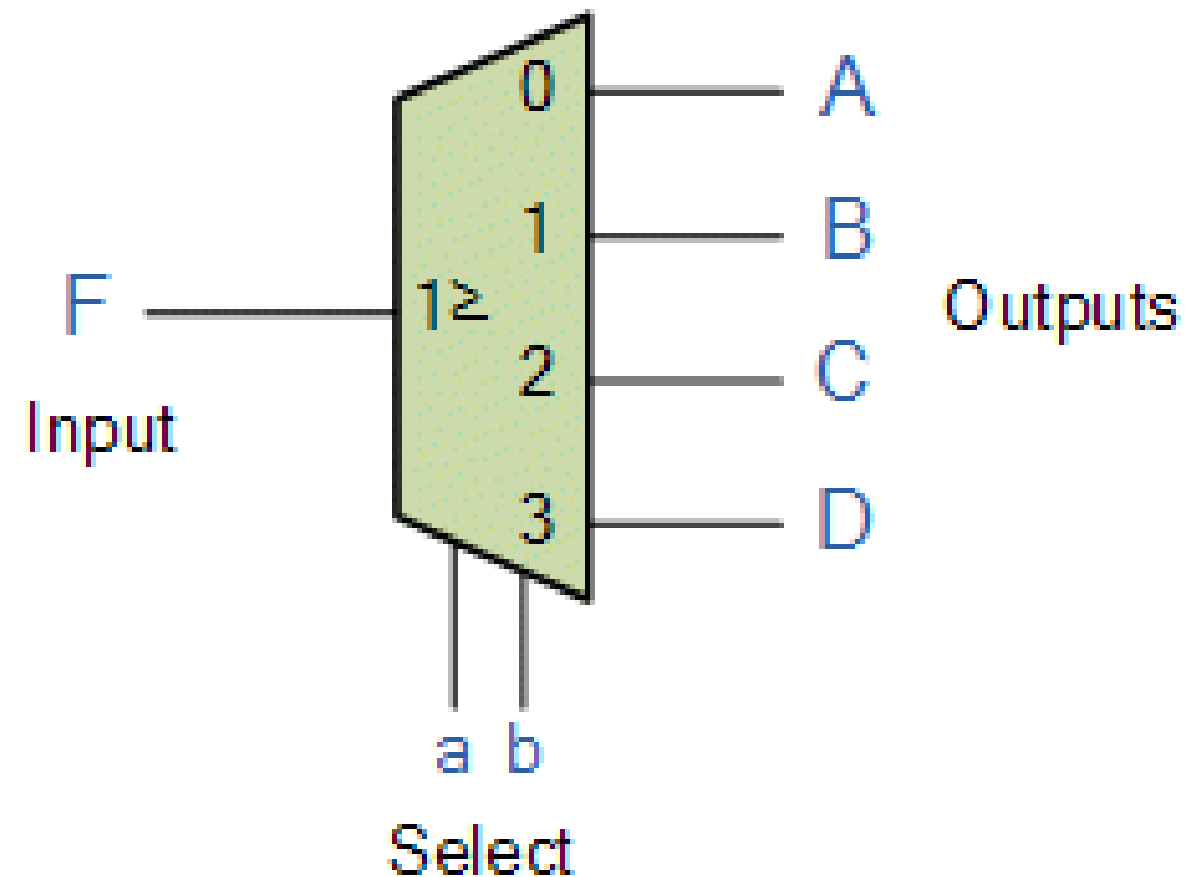



DeMultiplexer - Types

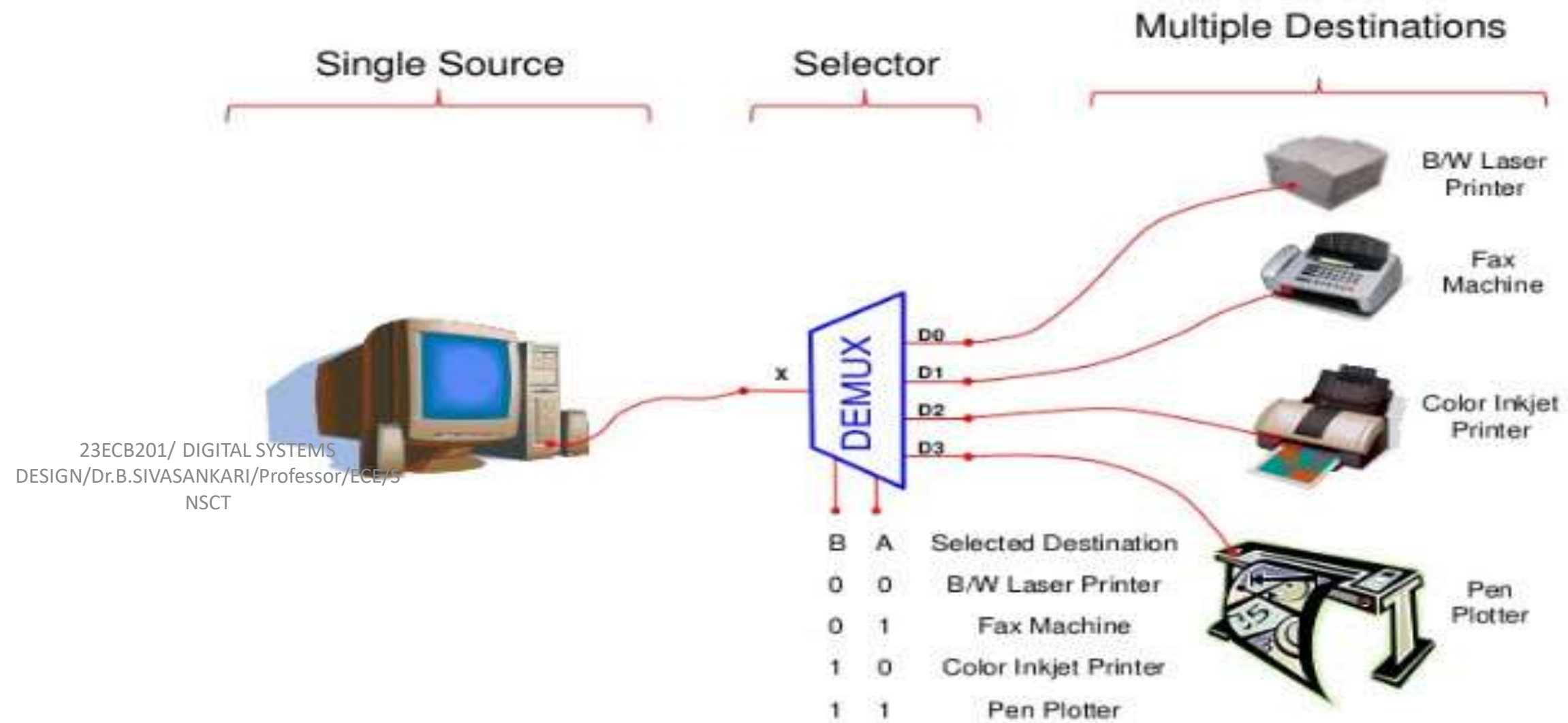

9/18/2024



1x4 De-Multiplexer



- 1x4 De-Multiplexer has one input I, two selection lines, s1 & s0 and four outputs Y3, Y2, Y1 & Y0.

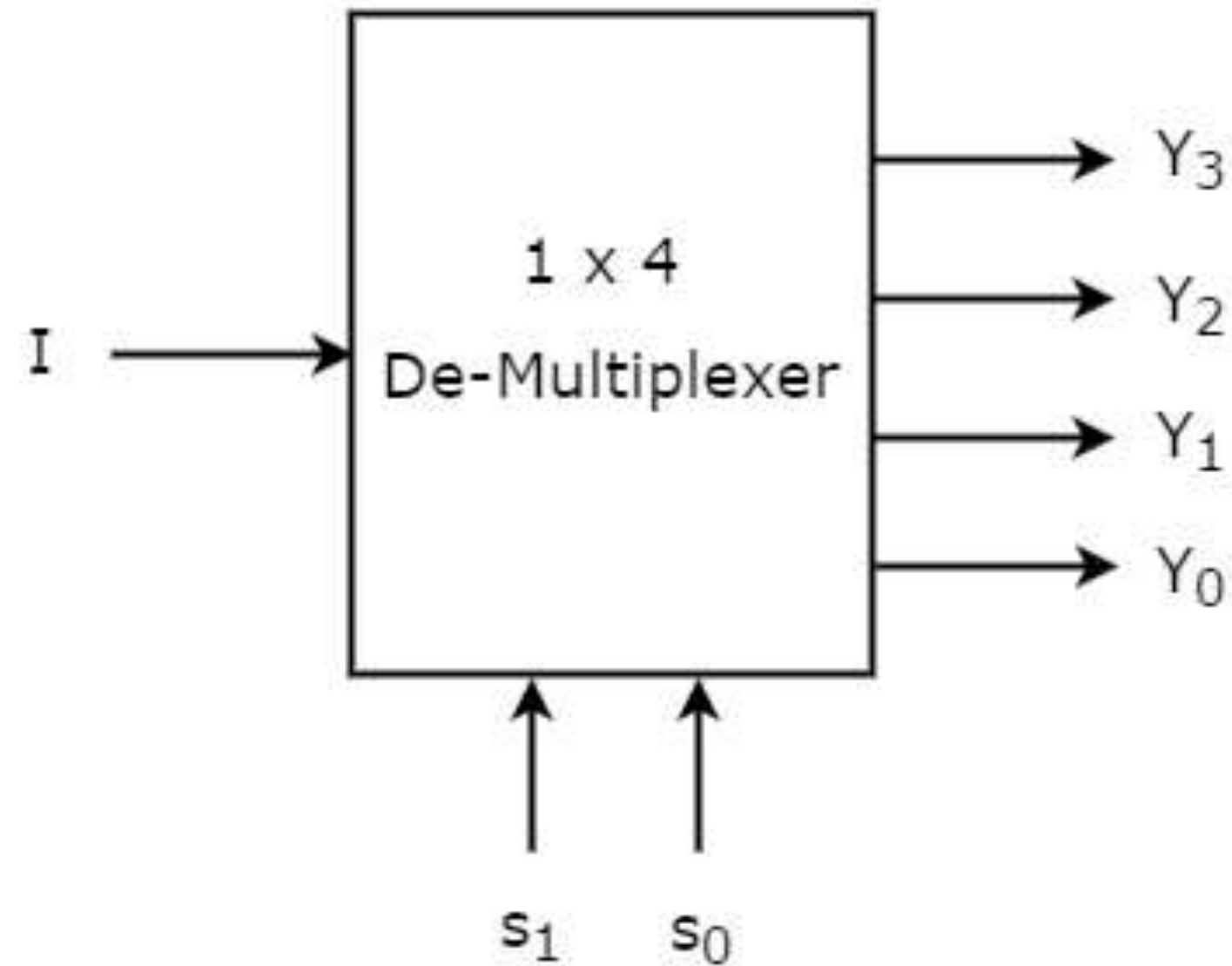



- The single input 'I' will be connected to one of the four outputs, Y3 to Y0 based on the values of selection lines s1 & s0. The Truth table of 1x4 De-Multiplexer is shown below.

Selection Inputs		Outputs			
S ₁	S ₀	Y ₃	Y ₂	Y ₁	Y ₀
0	0	0	0	0	I
0	1	0	0	I	0
1	0	0	I	0	0
1	1	I	0	0	0



We can implement these Boolean functions using Inverters & 3-input AND gates. The circuit diagram of 1x4 De-Multiplexer is shown in the following figure.

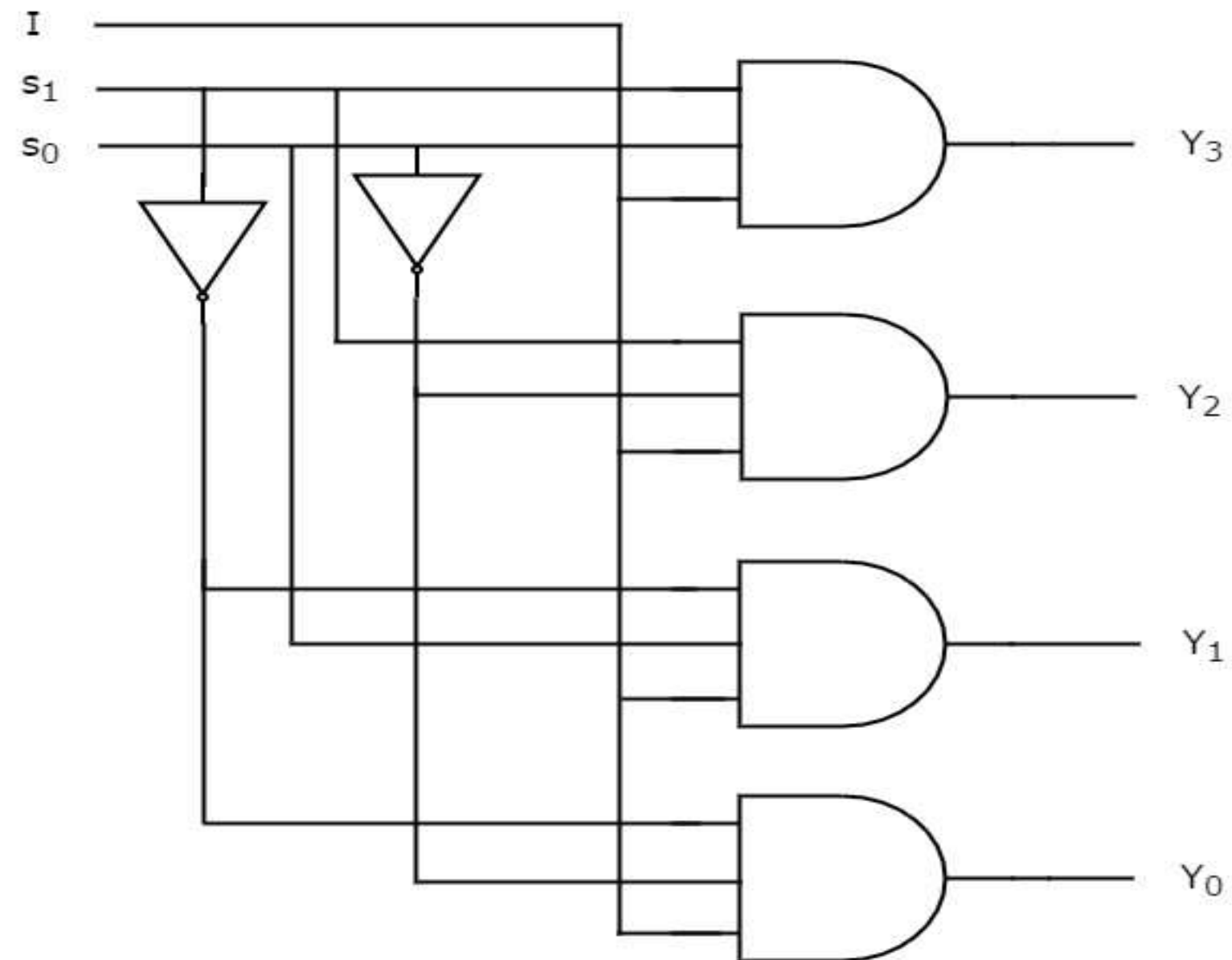



1x8 De-Multiplexer



1x8 De-Multiplexer has single input, three selection lines and eight outputs.

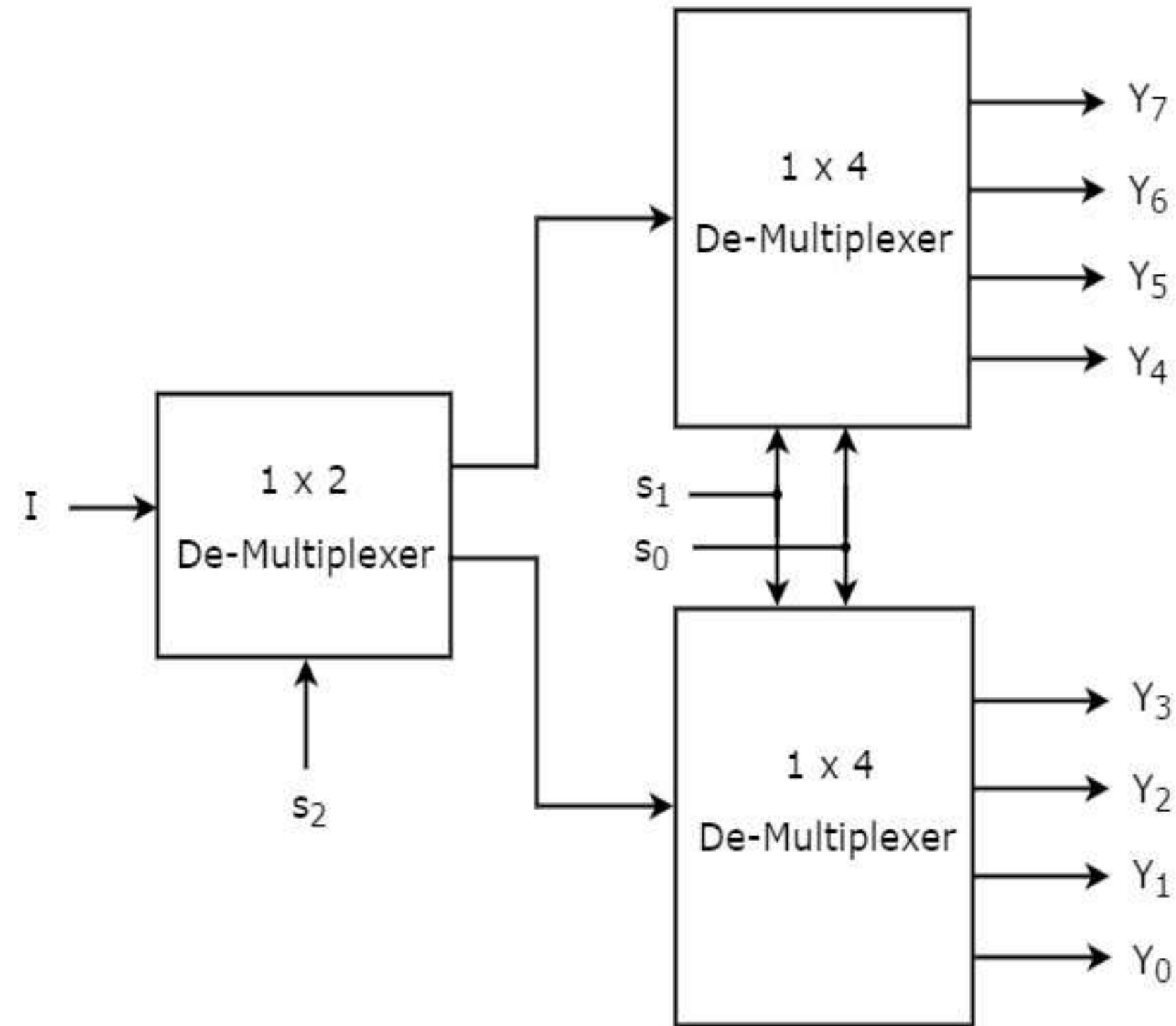



1x8 De-Multiplexer has one input I, three selection lines s₂, s₁ & s₀ and outputs Y₇ to Y₀. The Truth table of 1x8 De-Multiplexer is shown below.

Selection Inputs			Outputs							
s ₂	s ₁	s ₀	Y ₇	Y ₆	Y ₅	Y ₄	Y ₃	Y ₂	Y ₁	Y ₀
0	0	0	0	0	0	0	0	0	0	I
0	0	1	0	0	0	0	0	0	I	0
0	1	0	0	0	0	0	0	I	0	0
0	1	1	0	0	0	0	I	0	0	0
1	0	0	0	0	0	I	0	0	0	0
1	0	1	0	0	I	0	0	0	0	0
1	1	0	0	I	0	0	0	0	0	0
1	1	1	I	0	0	0	0	0	0	0



Applications

Demultiplexer is used to connect a single source to multiple destinations. The main application area of demultiplexer is communication system where multiplexer are used.

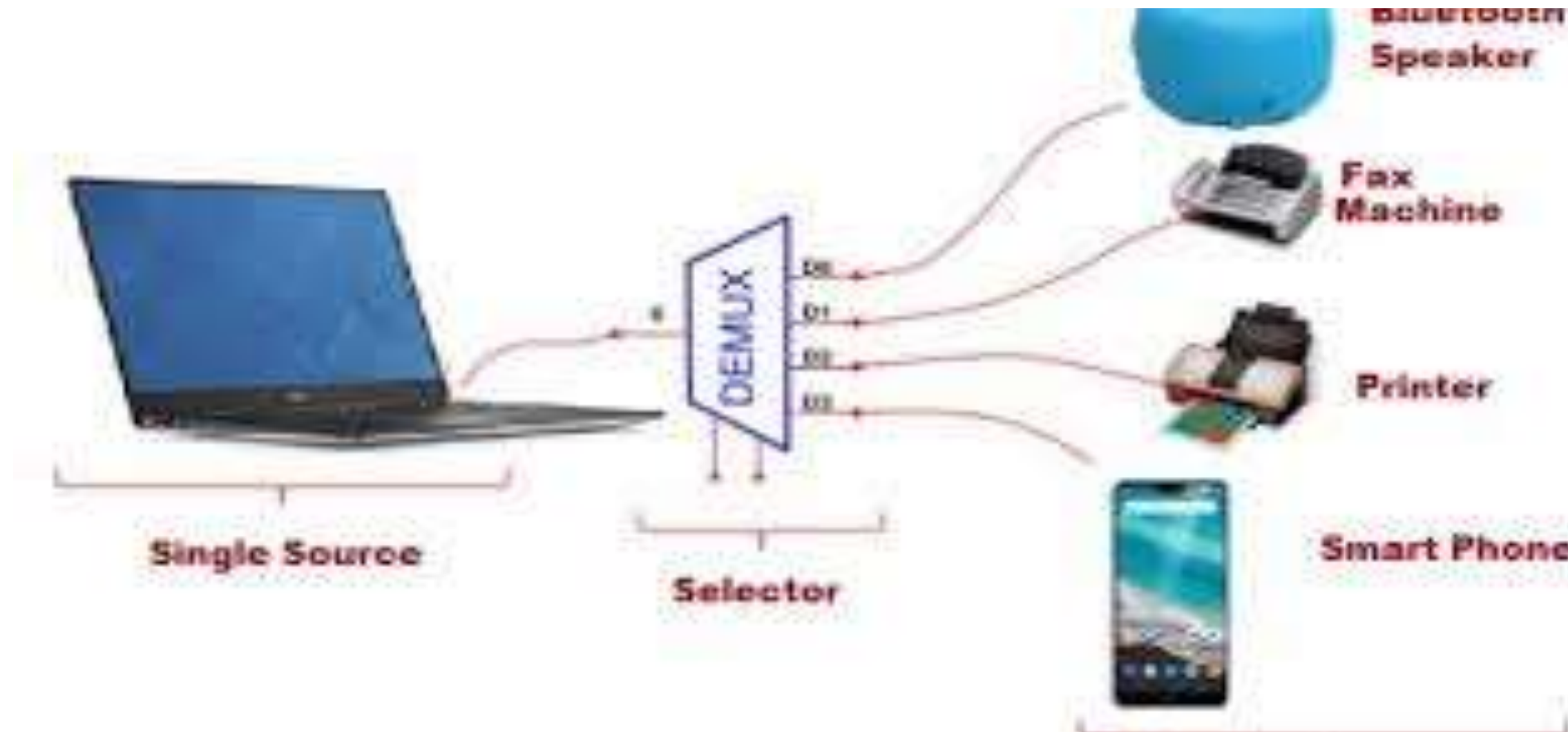

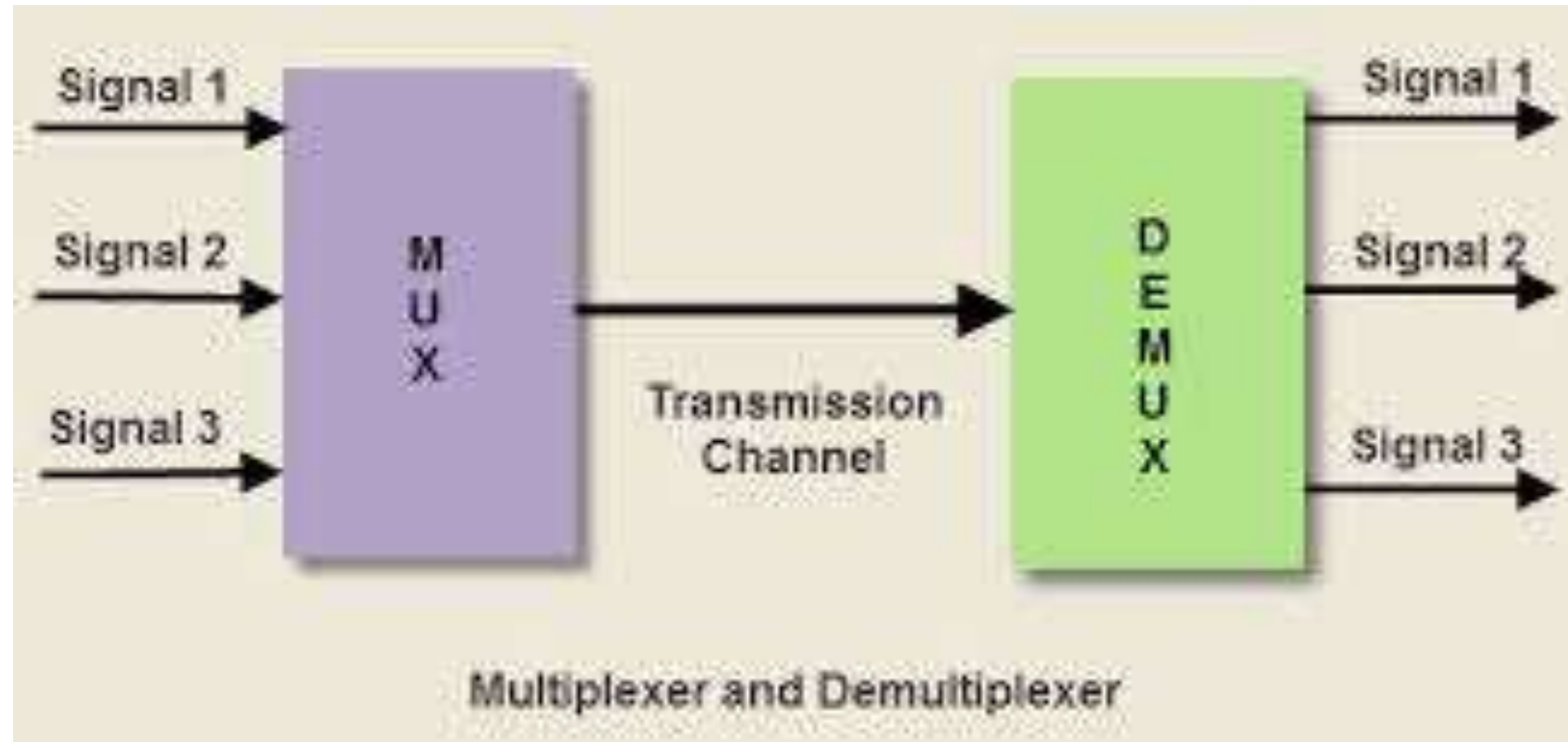



ASSESSMENTS



THINK
(Yourself)



PAIR
(With a partner)



SHARE
(Whole class)



THANK YOU