



SNS COLLEGE OF TECHNOLOGY

Coimbatore-35
An Autonomous Institution



Accredited by NBA – AICTE and Accredited by NAAC – UGC with 'A++' Grade
Approved by AICTE, New Delhi & Affiliated to Anna University, Chennai

DEPARTMENT OF ELECTRONICS & COMMUNICATION ENGINEERING

23ECB201 – DIGITAL SYSTEMS DESIGN

II YEAR/ III SEMESTER

1

UNIT 2 – COMBINATIONAL CIRCUITS

TOPIC 2.4 – DECODER AND ENCODER



WHAT IS A DECODER?

- **Decoder** is a combinational logic circuit that converts binary information from the n coded inputs to a maximum of 2^n unique outputs.

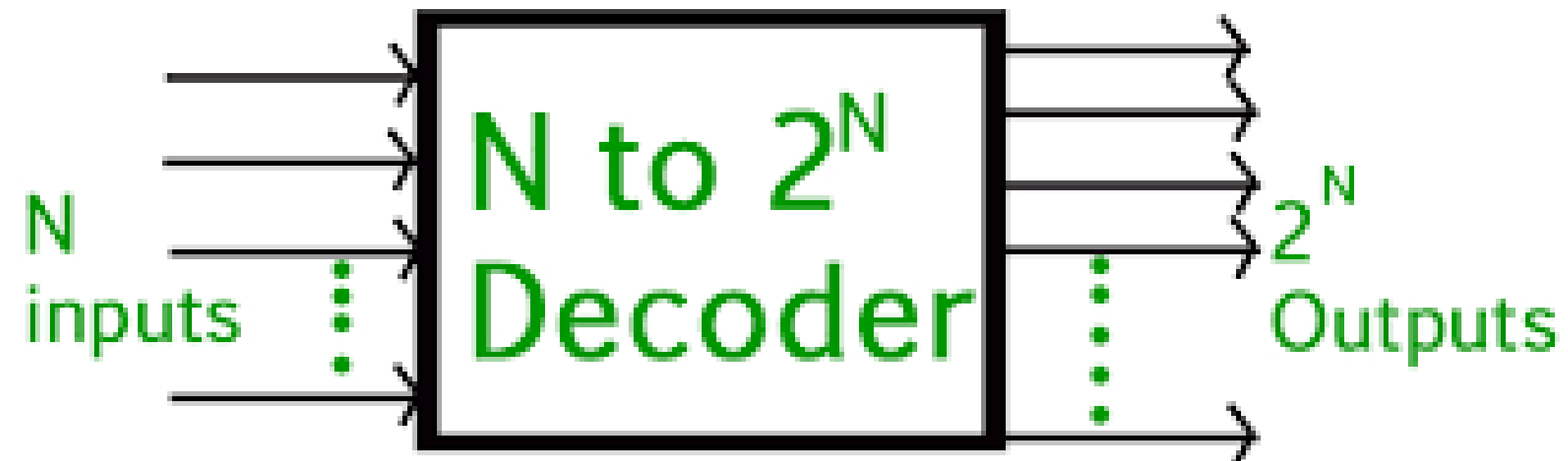



DECODER



A decoder has

- n inputs
- 2^n outputs
- A decoder selects one of 2^n outputs by decoding the binary value on the n inputs.
- The decoder generates all of the minterms of the n input variables.
- Exactly one output will be active for each combination of the inputs.

What does "active" mean?



DECODER

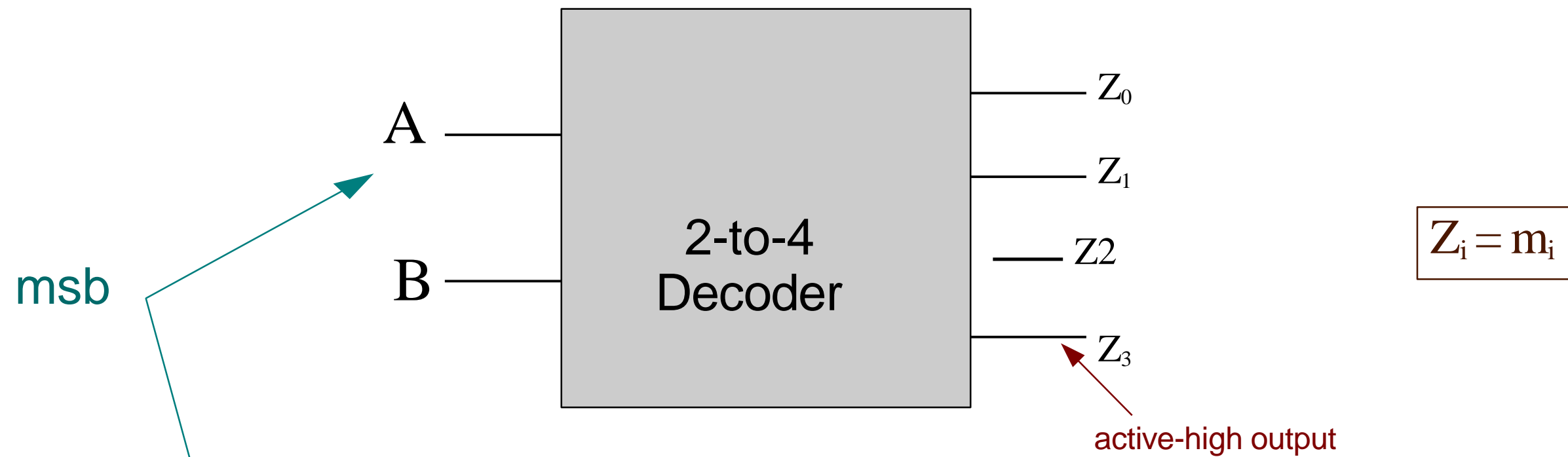

A	B	Z_0	Z_1	Z_2	Z_3	
0	0	1	0	0	0	m_0
0	1	0	1	0	0	m_1
1	0	0	0	1	0	m_2
1	1	0	0	0	1	m_3



DECODER

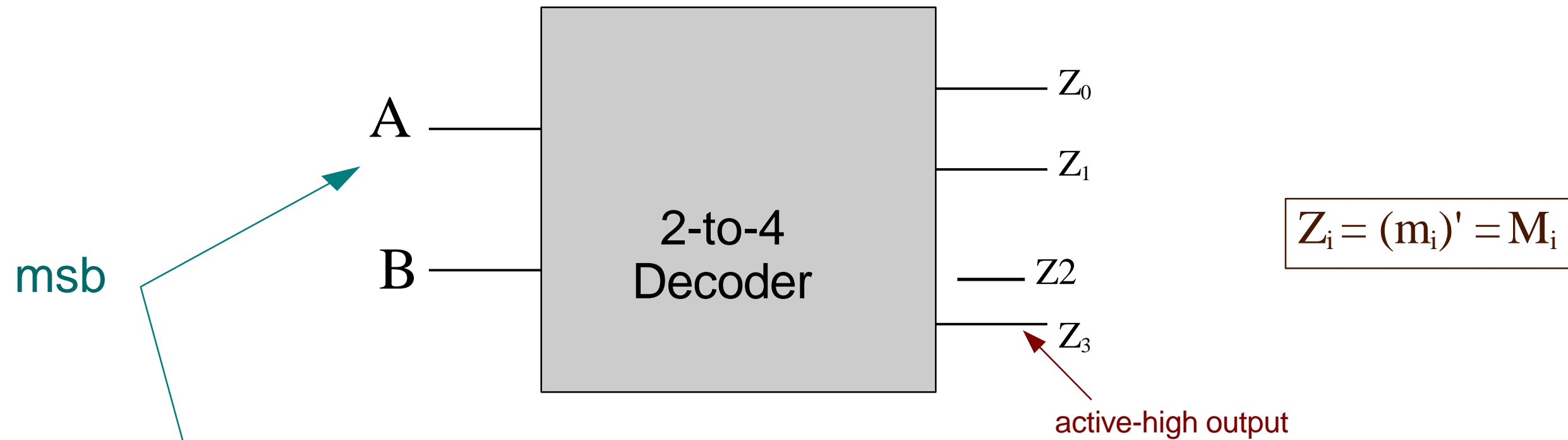

A	B	Z ₀	Z ₁	Z ₂	Z ₃	
0	0	1	0	0	0	m ₀
0	1	0	1	0	0	m ₁
1	0	0	0	1	0	m ₂
1	1	0	0	0	1	m ₃



DECODERS

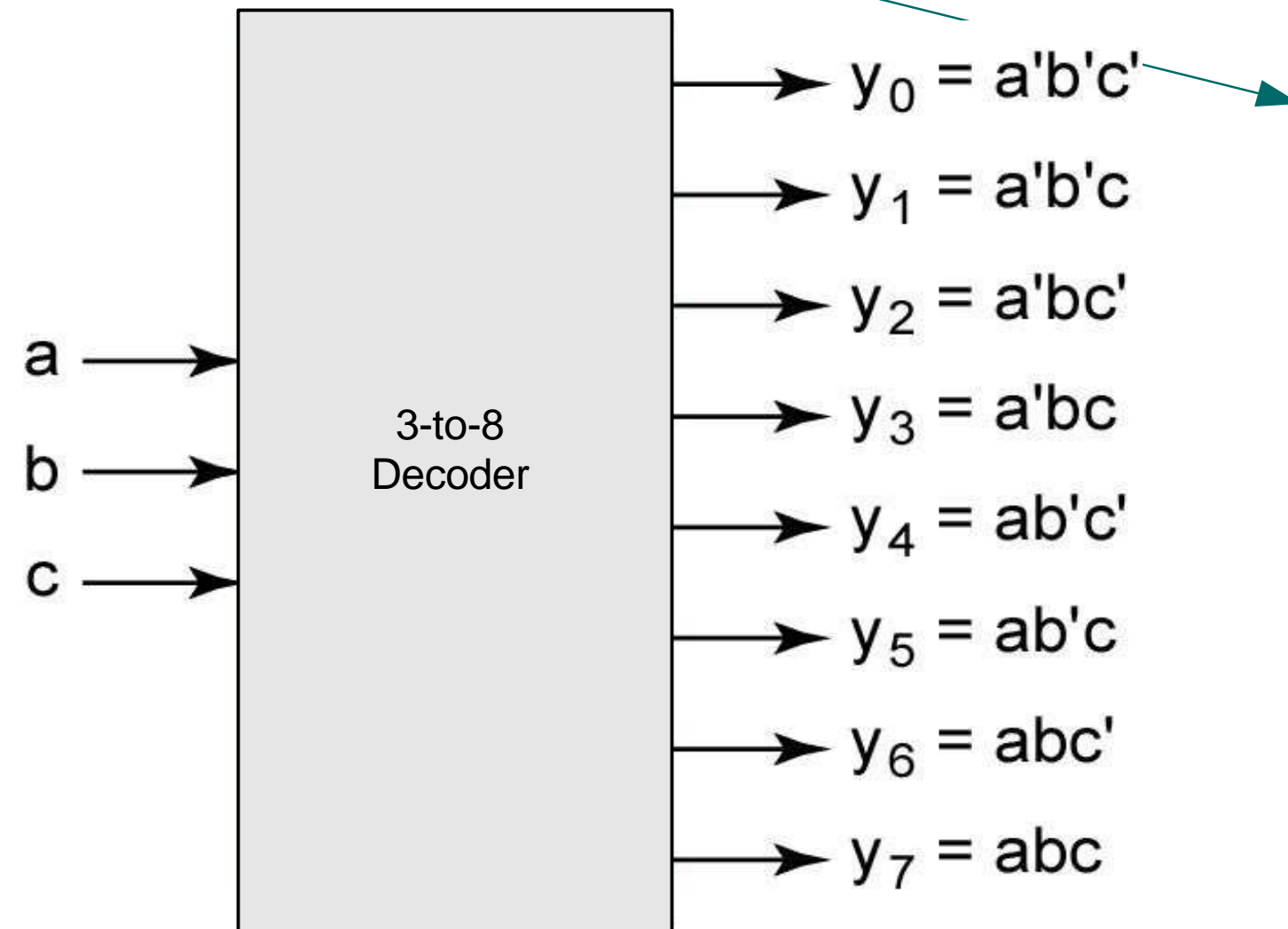

a	b	c	y_0	y_1	y_2	y_3	y_4	y_5	y_6	y_7
0	0	0	1	0	0	0	0	0	0	0
0	0	1	0	1	0	0	0	0	0	0
0	1	0	0	0	1	0	0	0	0	0
0	1	1	0	0	0	1	0	0	0	0
1	0	0	0	0	0	0	1	0	0	0
1	0	1	0	0	0	0	0	1	0	0
1	1	0	0	0	0	0	0	0	1	0
1	1	1	0	0	0	0	0	0	0	1



Decoder with Enable

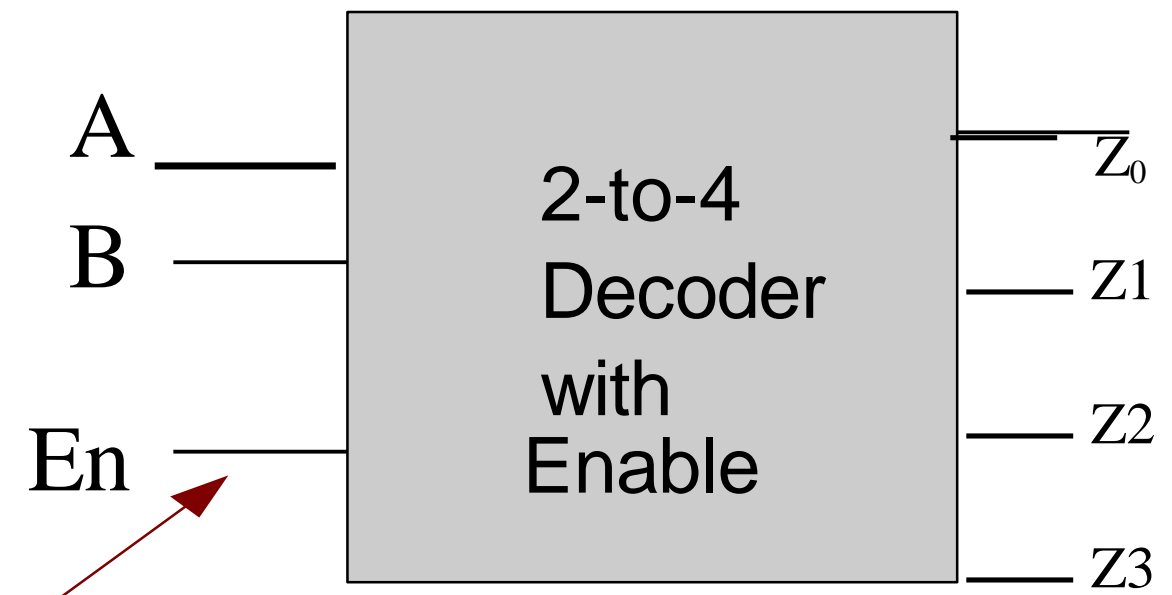

active-high enable

En	A	B	Z ₀	Z ₁	Z ₂	Z ₃
1	0	0	1	0	0	0
1	0	1	0	1	0	0
1	1	0	0	0	1	0
1	1	1	0	0	0	1
0	x	x	0	0	0	0

Encoder & Decoder/23ECB201/Dr
B.SIVASANKARI/Professor/ECE/SNSCT

enabled

disabled



Decoder with Enable

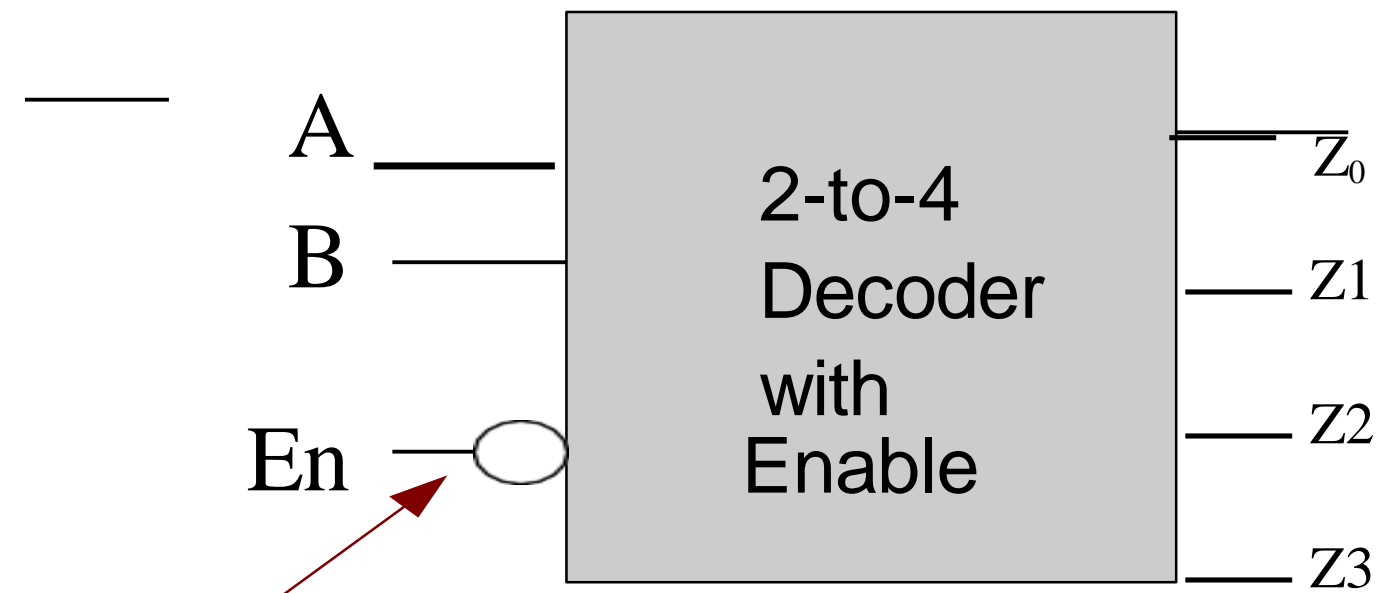

active-Low enable

En	A	B	Z ₀	Z ₁	Z ₂	Z ₃
0	0	0	1	0	0	0
0	0	1	0	1	0	0
0	1	0	0	0	1	0
0	1	1	0	0	0	1
1	x	x	0	0	0	0

enabled

disabled



ACTIVITY



How Many Words in a Minute

Level: Any

Time: 15 minutes

Materials: Vocab groups to revise
A watch to time a minute





WHY ENCODERS?



An encoder has

- 2^n inputs
- n outputs

Outputs the binary value of the selected (or active) input.

Performs the inverse operation of a decoder. Issues

- What if more than one input is active?
- What if no inputs are active?

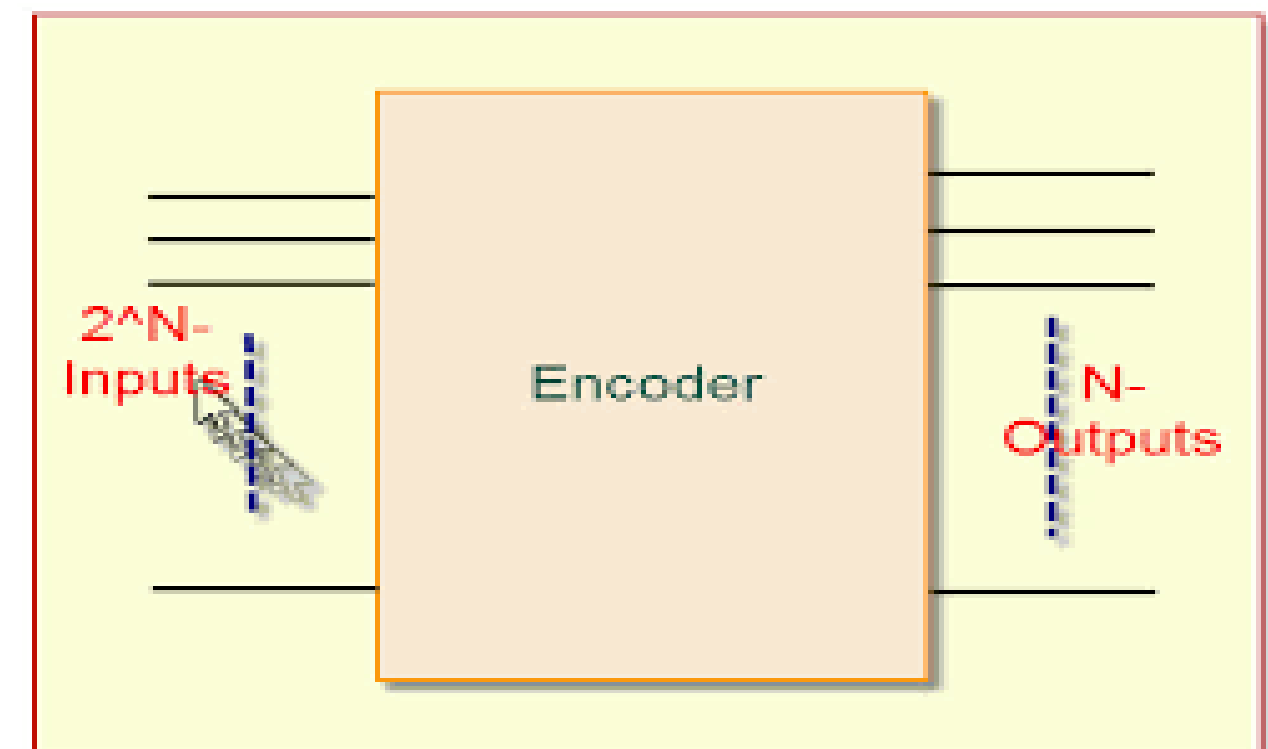



Encoders

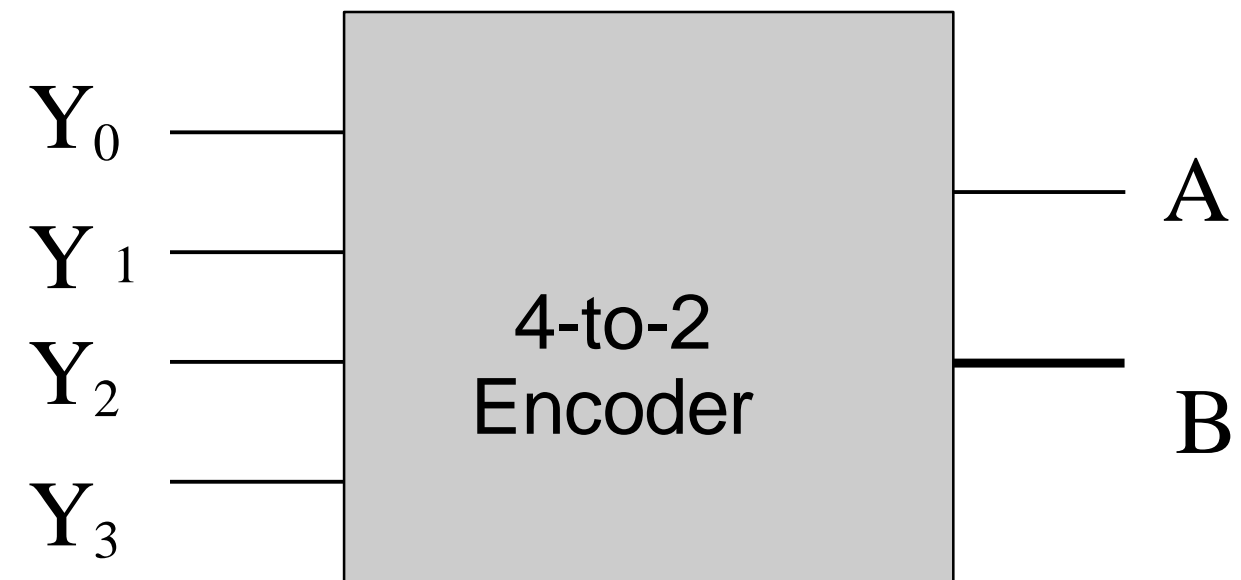

Y_0	Y_1	Y_2	Y_3	A	B
1	0	0	0	0	0
0	1	0	0	0	1
0	0	1	0	1	0
0	0	0	1	1	1

Encoder & Decoder/23/ECB201/Dr.
B.SIVASANKARI/Professor/ECE/SNSCT



Priority Encoders



- If more than one input is active, the higher-order input has priority over the lower-order input.
 - The higher value is encoded on the output
- A valid indicator, d , is included to indicate whether or not the output is valid.

Encoder & Decoder/23ECB201/Dr. B.SIVA SANKARI, Professor/ECE/SSNCT 12

Output is invalid when no inputs are active

- $d = 0$
- $d = 1$
- Output is valid when at least one input is active

Why is the valid indicator needed?



Priority Encoders

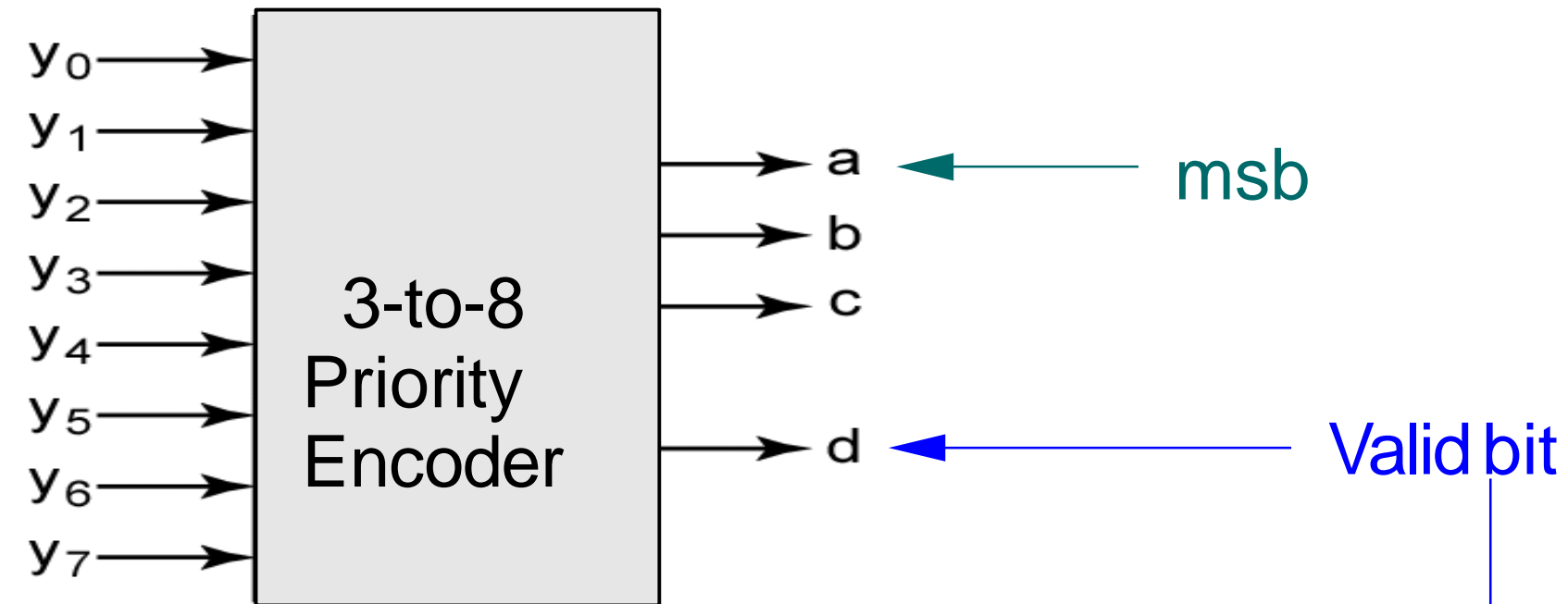

y_0	y_1	y_2	y_3	y_4	y_5	y_6	y_7	a	b	c	d
0	0	0	0	0	0	0	0	0	0	0	0
1	0	0	0	0	0	0	0	0	0	0	1
X	1	0	0	0	0	0	0	0	0	1	1
X	X	1	0	0	0	0	0	0	1	0	1
X	X	X	1	0	0	0	0	0	1	1	1
X	X	X	X	1	0	0	0	1	0	0	1
X	X	X	X	X	1	0	0	1	0	1	1
X	X	X	X	X	X	1	0	1	1	0	1
X	X	X	X	X	X	X	1	1	1	1	1

Encoder & Decoder/23ECB201/Dr.
B.SIVASANKARI/Professor/ECE/SNSCT



Using an n -output Decoder



- Use an n -output decoder to realize a logic circuit for a function with n minterms.
- Each minterm of the function can be mapped to an output of the decoder.
- For each row in the truth table, for the function, where the output is 1, sum (or “OR”) the corresponding outputs of the decoder.

Encoder & Decoder/23ECB201/Dr.
B.SIVASANKARI/Professor/ECE/SNSCT

14

- That is, for each minterm in the minterm expansion of the function, OR the corresponding outputs of the decoder.

Leave remaining outputs of the decoder unconnected.



Using an n -output Decoder

Example

- Using a 3-to-8 decoder, design a logic circuit to realize the following Boolean function

Encoder & Decoder/23ECB201/Dr.
B.SIVASANKARI/Professor/ECE/SNSCT

- $F(A,B,C) = \sum m(2, 3, 5, 6, 7)$



Using an n -output Decoder



Example

- Using a 2-to-2 decoder, design a logic circuit to realize the following Boolean function

16

$$F(A,B,C) = \sum m(0, 1, 4, 6, 7)$$



ASESSMENT



1. What is a Encoder?
2. Device which converts an input device state into a binary representation of ones or zeros is termed as

1. **Encoder**

2. Decoder

3. Multiplexer

Encoder & Decoder/23ECB201/Dr.
B.SIVASANKAR/Professor/ECE/SNSCT

4. Data selector

17

3. A decoder converts n inputs to _____ outputs.(2^n)
4. ----- are building blocks of encoders.(Ans - OR gate)
5. Draw the block diagram of 2x4 decoder.



THANK YOU